

Rechtwinklige Kraftübertragung
Right-angle power transmission



www.atek.de

ATEK
ANTRIEBSTECHNIK

ATEK in Deutschland



ANTRIEBSTECHNIK

ATEK Antriebstechnik Willi Glapiak GmbH
Siemensstrasse 47 · D-25462 Rellinggen
Tel.: +49 - (0)4101 7953-0
E-Mail: atek@atek.de · Web: www.attek.de

ATEK in Germany

Verkauf
Sales

Tel.: +49 - (0)4101 7953-22/23/48
Fax: +49 - (0)4101 7953-21
E-Mail: sales@atek.de

Einkauf / Materialwirtschaft
Purchase

Tel.: +49 - (0)4101 7953-11
Fax: +49 - (0)4101 7953-21
E-Mail: purchase@atek.de

Technik
Technics

Tel.: +49 - (0)4101 7953-12/47
Fax: +49 - (0)4101 7953-21
E-Mail: technics@atek.de

Kaufmännischer Bereich
Commercial Department

Tel.: +49 - (0)4101 7953-15
Fax: +49 - (0)4101 7953-20
E-Mail: commercial@atek.de

Vertreterbezirke Inland Sales Offices Germany

20 HEINRICH WOLF GmbH & Co. KG
Röntgenstr. 1
23701 Eutin
Tel.: +49 4521 79677-0
Fax: +49 4521 79677-29
info@wolf-eutin.de
www.wolf-eutin.de

30 INFRA Antriebe Hans Nelk GmbH
Alter Kirchpfad 6a
32657 Lemgo
Tel.: +49 5261 3445
Fax: +49 5261 15641
Mobil H. Nelk:
+49 171 5248674
Mobil E. Vehling:
+49 160 6319197
info@infra-antriebe.de
www.infra-antriebe.de

**40 Hasske und Meermann
Antriebstechnik GmbH**
Forststrasse 51
40721 Hilden
Tel.: +49 2103 5821-0
Fax: +49 2103 5821-25
hi@hasskeundmeermann.de
www.hasskeundmeermann.de

50 Ingenieurbüro Weber
Mengelröder Weg 2b
37308 Heilbad Heiligenstadt
Tel.: +49 3606 506144
Fax: +49 3606 506145
Mobil Werner Weber:
+49 172 8032261
ib.weber@gmx.de

**60 Bretzel GmbH
Antriebs- und Elektrotechnik**
Industriestr. 9
65760 Eschborn
Tel.: +49 6196 40319-0
Fax: +49 6196 43047
Mobil Klaus Kilper:
+ 49 175 5228744
info@bretzel-gmbh.de
www.bretzel-gmbh.de

70 B&K Antriebstechnik GmbH
Anhauser Str. 76
89547 Gerstetten-Deitingen
Tel.: +49 7324 91012-0
Fax: +49 7324 91012-25
info@b-k-antriebstechnik.de
www.b-k-antriebstechnik.de

**80 KW Antriebs- &
Automationstechnik GmbH**
Koberger Str. 39
90408 Nürnberg
Tel.: +49 911 366 388 889
Fax: +49 911 366 389 0
Mobil Siegfried Wiegärtner:
+49 172 8104772
Mobil Harald Kraus:
+49 172 8123444
info@kw-antriebstechnik.de
www.kw-antriebstechnik.de

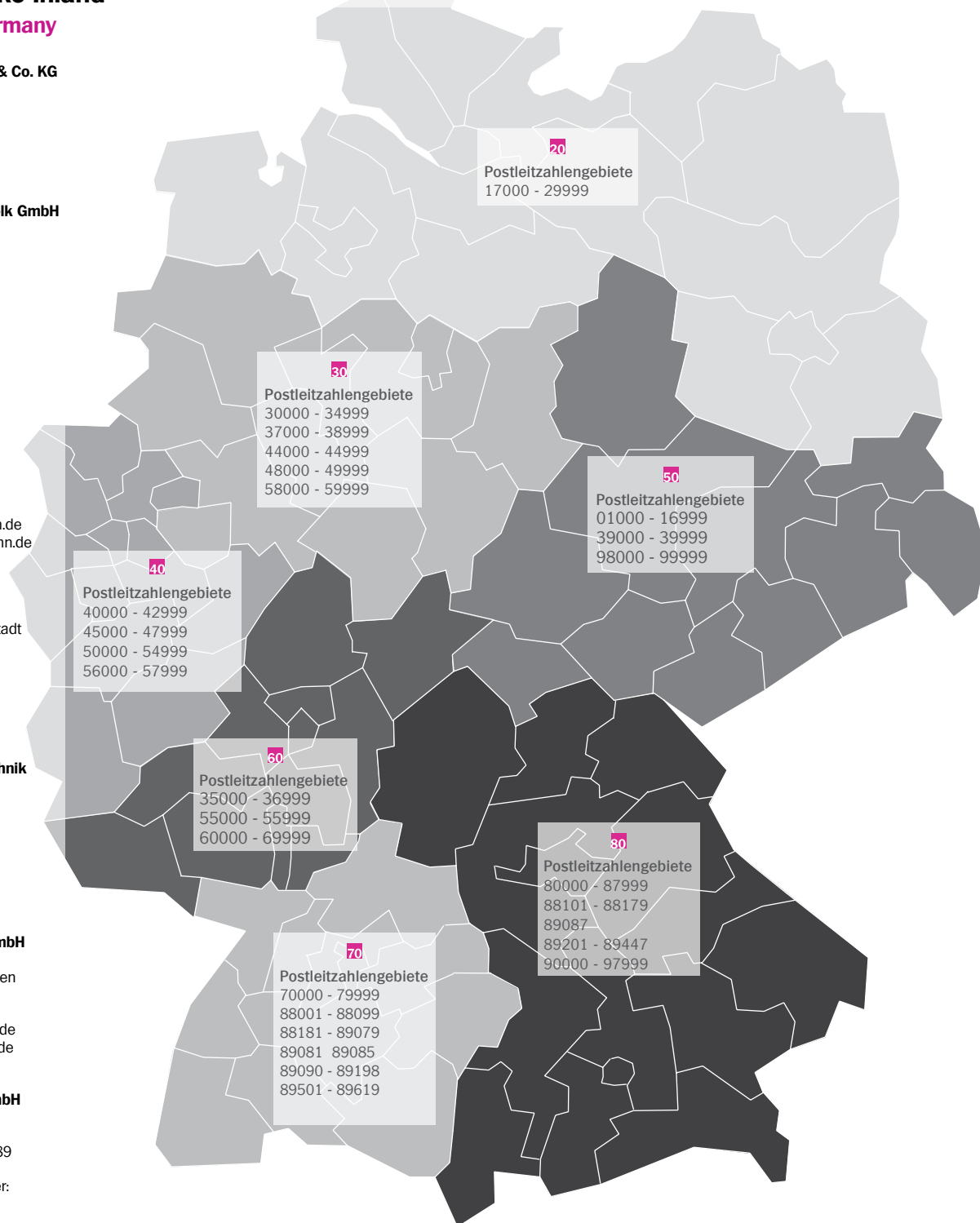

ATEK weltweit

Auslandsvertretungen

Foreign distributors

AUSTRALIEN / AUSTRALIA

Mecco Mech. Comp. PTY Ltd.
193 Orange Valley Road
6076 Kalamunda
Tel.: +61 89 2910000
Fax: +61 89 2910066
meccocomp@gmail.com
www.mecco.com.au

BELGIEN / BELGIUM

Bege Aandrijftechniek BVBA
Puttestraat 73
2940 Stabroek
Tel.: +32 36 051605
Fax: +32 36 053605
bege@bege.be
www.bege.be

DÄNEMARK / DANMARK

Regal A / S
Industrivej 4
4000 Roskilde
Tel.: +45 46 777000
Fax: +45 46 757620
regal@regal.dk
www.regal.dk

FRANKREICH / FRANCE

Comp'Aut.Sarl
78 rue Carnot
74000 Annecy
Tel.: +33 45057 0791
Fax: +33 45057 2145
contact@compaut.com
www.compaut.com

INDIEN / INDIA

Power Ace Eng. Co.
17AF, New Empire Ind. Estate
Kondivita Lane, Andheri(e)
400059 Mumbai
Tel.: +91 22 28205862
Fax: +91 22 28202478
response@poweraceindia.com
www.poweraceindia.com

ITALIEN / ITALY

SETEC S.p.A.
Via Mappano 17
10071 Borgaro Torinese Torino
Tel.: +39 011 4518611
Fax: +39 011 4704891
info.to@setec-group.it
www.setec-group.it

NIEDERLANDE / NETHERLANDS

Bege Aandrijftechniek B.V.
Anton Philipsweg 30
2171 KX Sassenheim
Tel.: +31 252 220220
Fax: +31 252 218484
bege@bege.nl
www.bege.nl

NORWEGEN / NORWAY

Centa Transmisjoner A.S.
Breiliveien 49
3217 Sandefjord
Tel.: +47 334 83100
Fax: +47 334 83110
centa@centa.no
www.centa.no

ÖSTERREICH / AUSTRIA

Ing. Franz Henzinger Ges.m.b.H
Ignaz-Mayer-Str. 4
4020 Linz
Tel.: +43 732 774580
Fax: +43 732 774584
office@henzinger.at
www.henzinger.at

POLEN / POLAND

DEMERO SP.j.
Ul. Graniczna 145
54-530 Wroclaw
Tel.: +48 71 3882300
Fax: +48 71 3882311
biuro@demero.pl
http://www.demero.pl

RUSSLAND / RUSSIA

Stankoservice-Sokol 000
ul. Tschasowaya 28, Gebäude 4
125315 Moskau
Tel.: +7 49 52251339
Fax: +7 49 52251339
info@stserv.ru
www.stserv.ru

SCHWEDEN / SWEDEN

Nord Drivsystem AB
Ryttargatan 277
19471 Upplands Väsby
Tel.: +46 859 411400
Fax: +46 859 411414
info@nord-se.com
www.nord.com

SCHWEIZ / SWITZERLAND

Flohr Industrietechnik GmbH
Ziilistude 164
5465 Mellikon
Tel.: +41 56 2670810
Fax: +41 56 2670825
info@flohr-industrietechnik.ch
www.flohr-industrietechnik.ch

SÜDAFRIKA / SOUTH AFRICA

Remag (Pty) Ltd.
Midway Park
31 Gallagher Avenue
1685 Midrand
Tel.: +27 11 3155672
Fax: +27 11 3155570
remag@intekom.co.za

SPANIEN / SPAIN

Amel Tecnica Industrial S.L.
Sant Miquel, 59
08208 Sabadell
Tel.: +34 937 162424
Fax: +34 937 162458
xcomas@ameltecnica.com

SÜD-KOREA / SOUTH KOREA

Alpha Tech Co., LTD
#4F, 768-4, Ojung-Dong, Ojung-Ku
421-170 Bucheon-City, Kyunggi-Do
Tel.: +82 32 6243848
Fax: +82 32 6243849
tklee64@hanafos.com

TSCHHECHISCHE REPUBLIK / CZECH REPUBLIC

RAVEO s.r.o.
Trida Tomase Bati 332
76502 Otrokovice
Tel.: +42 05 77663875
Fax: +42 05 77663875
info@raveo.cz
www.raveo.cz

TÜRKEI / TURKEY

Servo Kontrol Ltd. Sti
Perpa Ticaret Merkezi B Blok Kat: 11
No: 1609
80270 Okmeydani / Istanbul
Tel.: +90 212 320 30 80
Fax: +90 212 320 30 81
info@servokontrol.com
www.servokontrol.com

VOLKSREPUBLIK CHINA / PEOPLE'S REPUBLIC OF CHINA

SEW-Eurodrive (Tianjin) Co Ltd.
No. 46, 7th Avenue Tianjin Economic
Technological Development Area
Tianjin 300457
Tel.: +86 22 59836655
Fax: +86 22 59836651
info@sew-eurodrive.com.cn
www.sew-eurodrive.com.cn

Beijing Genju Science and Technology Development Co Ltd.

Jin Gu Mansions, No. 55,
Xingshikou Road, Haidian District,
Beijing 100195
Tel.: +86 10 88459170
Fax: +86 10 88454543
info@genju.com.cn
www.genju.com.cn

SINGAPUR, MALAYSIA, INDONESIA / SINGAPORE, MALAYSIA, INDONESIA

SM Component
196 Pandan Loop #06-01
Pantech Business Hub
Singapore 128384
Tel.: +65 6569 1110
Fax: +65 6569 2220
sales@sm-component.com

Auflage Januar 2013 / Issue January 2013

Rechtlicher Hinweis:

Trotz sorgfältiger Bearbeitung übernehmen wir für die Richtigkeit der Inhalte keine Gewähr. Mit der Herausgabe dieses Katalogs verlieren alle früheren Kataloge ihre Gültigkeit. Wir behalten uns das Recht vor, Konstruktion, Gewicht und Abmessungen unserer Winkelgetriebe zu ändern. Lieferungen und Leistungen erfolgen zu unseren „Allgemeinen Geschäftsbedingungen“.

Terms of business, note:

We assume no responsibility for the correctness of contents. All previous catalogues become invalid with the publication of this catalogue. We reserve the right to modify the design, weight and dimensions of our right angle drives. Delivery and services in accordance with our "General Terms of Business".

Übersicht / Overview



1. Auswahlkriterien / Selection Criteria

- Material, Ausführungen, Bauarten, Übersetzungen
- Wirkungsgrad, spielarme Ausführung, Befestigungsseite
- Vorzugsdrehrichtung, Schmierung, Schmier­tabelle
- Entlüftungsfilter, **Leistungs- und Drehmomenttabellen**
- *Material, designs, models, transmissions*
- *Efficiency, low backlash version, Mounting Side*
- *Preferential direction of rotation, lubrication, lubrication table*
- *Position of vent filter, power and torque tables*

2. Typ V

- Durchgehende Welle langsamlaufend
- Übersetzungen: $i = 1:1$ bis $6:1$
- Max. Abtriebsmomente bis $T_{2\max} = 5400\text{Nm}$
- 9 Getriebegrößen von 065 bis 350 mm Kantenlänge
- *Continuous shaft, slow running*
- *Transmission ratios: $i = 1:1$ to $6:1$*
- *Max. output torque up to $T_{2\max} = 5.400\text{Nm}$*
- *9 gear unit sizes from 065 to 350 mm edge length*

3. Typ VS

- Durchgehende Welle schnelllaufend
- Übersetzungen: $i = 1,5:1$ und $2:1$
- Abtriebsnennmomente bis $T_{2N} = 1200\text{Nm}$
- 6 Getriebegrößen von 090 bis 260 mm Kantenlänge
- *Continuous shaft fast running*
- *Transmission ratios: $i = 1.5:1$ und $2:1$*
- *Rated output torque up to $T_{2N} = 1200\text{Nm}$*
- *6 gear unit sizes from 090 to 260 mm edge length*

4. Typ VL

- Antriebsseite mit Motorlaterne und Hohlwelle
- Passend zum Anbau von IEC-Normmotoren
- Durchgehende Welle langsamlaufend
- 8 Getriebegrößen von 065 bis 260 mm Kantenlänge
- *Drive end with motor bell housing and hollow shaft*
- *Compatible for installation of IEC standard motor*
- *Continuous shaft, slow running*
- *8 gear unit sizes from 065 to 260 mm edge length*

5. Typ VLM

- Mit angebautem IEC-Normmotor
- Abtriebsdrehzahlen 112 bis 2850min^{-1}
- Maximale Abtriebsmomente bis $T_{2N} = 1100\text{Nm}$
- 8 Getriebegrößen von 065 bis 260 mm Kantenlänge
- *With IEC standard motor*
- *Output speed 112 to 2850min^{-1}*
- *Max. output torque up to $T_{2\max} = 1100\text{Nm}$*
- *8 gear unit sizes from 065 to 260 mm edge length*

6. Abzweiggetriebe / Multi shaft gearboxes

- für Übersetzungen von $1,5$ bis $6:1$ bei Typ V
- für Übersetzungen von $1,5$ bis $2:1$ bei Typ VS
- mit Vollwelle oder Hohlwelle
- bis zu 6 Wellenenden
- *for ratios from 1.5 to 6:1 for type V*
- *for ratios from 1.5 to 2:1 for type VS*
- *with solid shaft or hollow shaft*
- *up to 6 shaft ends*

Bauarten und Drehrichtungen / Models and Rotational Directions

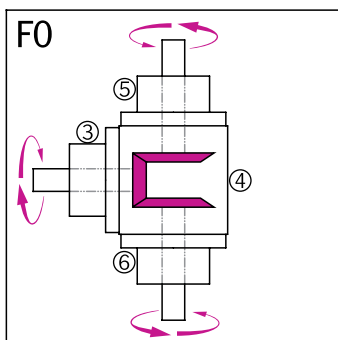
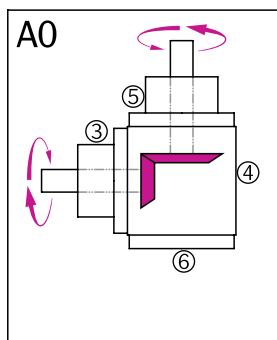

Die Bauart A0/F0 hat fliegend gelagerte Wellenenden.
Die An- und Abtriebsseite sind bei den Übersetzungen 1:1 bis 2:1 symmetrisch. Auch lieferbar als Bauart M0 mit 2 Ritzelwellen.

*Models A0 and F0 have shafts with single bearings.
The input and output sides are symmetrical at transmission ratios between 1:1 and 2:1. Also available as model M0 with 2 pinion shafts.*

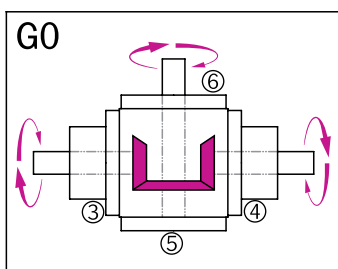
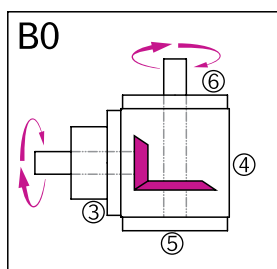

Die Bauart B0/G0 hat eine beidseitig gelagerte Abtriebswelle mit einseitigem Wellenzapfen gegenüber dem Kegelrad. Die Wellenenden haben dadurch die gleiche Drehrichtung.

In models B0 and G0, the output shaft has bearings on both sides and extends out away from the side where its bevel gear is located. In this design the shafts have the same direction of rotation.

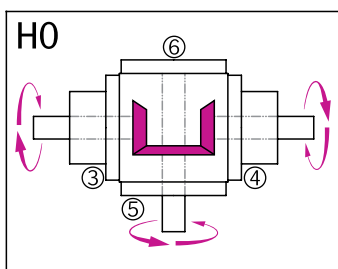
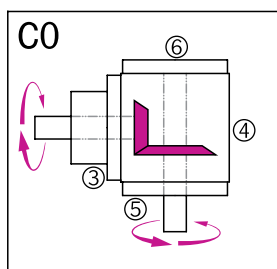

Die Bauart C0/H0 hat eine beidseitig gelagerte Abtriebswelle mit einseitigem Wellenzapfen an der Seite des Kegelrades. Die Wellenenden haben dadurch gegenläufige Drehrichtungen.

In models C0 and H0, the output shaft has bearings on both sides and extends out to the side where its bevel gear is located. In this design the shafts have opposing directions of rotation.

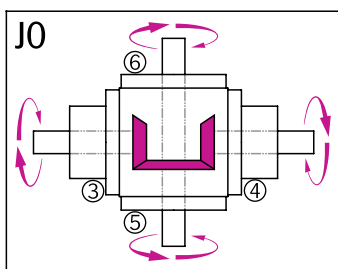
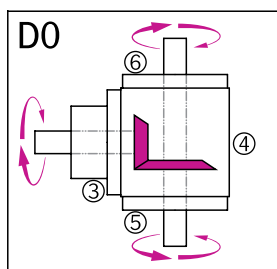

Die Bauart D0/J0 hat eine durchgehende Abtriebswelle. Wenn mehrere Getriebe hintereinander geschaltet werden sollen, kann das Getriebe mit verstärkter Welle geliefert werden.

Models D0 and J0 have a straight-through output shaft. If units are intended for arrangement in series, they can be supplied with reinforced straight-through shafts and bearings.

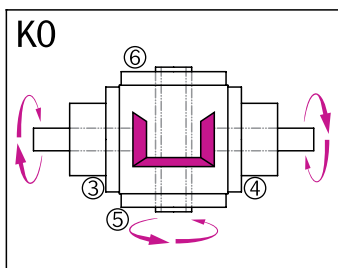
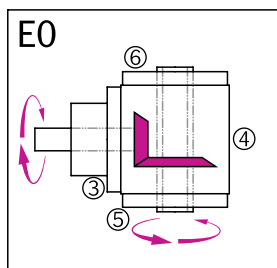

Die Bauart E0/K0 hat eine durchgehende Hohlwelle. Folgende Ausführungen sind lieferbar:
- mit oder ohne Nut, - mit Keilnabenprofil, - mit Polygonprofil.

*Models E0 and K0 have a straight-through hollow shaft. The following options are available:
- without keyway, - with spline profile, - with polygonal profile.*

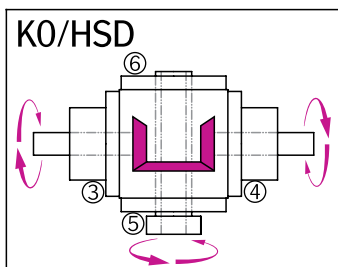
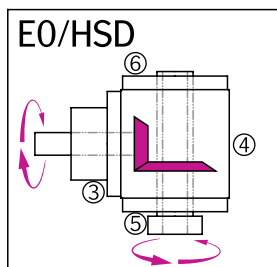

Die Bauart E0/K0/HSD hat eine abgesetzte Hohlwelle ohne Nut und eine Schrumpfscheibe zur kraftschlüssigen Drehmomentübertragung. Die Führungsseite ist mit einer Bronzebuchse versehen.

Models E0/HSD and K0/HSD have a stepped hollow shaft without a keyway and a shrunk-on disc for positive torque transmission. The guide side is fitted with a bronze guide bushing.

Auswahlkriterien / Selection Criteria

ATEK-Kegelradgetriebe haben kräftige Graugussgehäuse, gehärtete und paarweise geläppte Kegelräder mit Spiralverzahnung und reichlich dimensionierte Wälzlager. Spiralkegelräder bieten den entscheidenden Vorteil sehr günstiger Eingriffsverhältnisse (hoher Überdeckungsgrad). Sie sind dadurch prädestiniert für den Einsatz bei hohen Belastungen, gepaart mit optimaler Laufruhe und großer Übertragungsgenauigkeit. Die kreisbogenförmigen Zähne sind gegen Biegung widerstandsfähiger als gerade oder schräge Zähne. Ein weiterer Vorteil ist die relative Unempfindlichkeit gegen elastische Verformung von Rädern, Wellen und Lagern. Die Getriebe können daher auch extreme Stoßbelastungen übertragen. Zwölf Bauarten stehen serienmäßig zur Verfügung. 22 weitere Variationen sind als Abzweiggetriebe möglich. Die Getriebe können in allen Einbaulagen eingesetzt und mit vielfältigen Befestigungsbohrungen versehen werden. Deckel und Flansche werden generell mit Befestigungsbohrungen versehen.

Übersetzungen

Als Standard-Übersetzungen sind lieferbar: 1-1.5-2-3-4-5 und 6:1. Alle Übersetzungen sind mathematisch genau. Die Getriebe können für Übersetzungen ins Langsame und ins Schnelle eingesetzt werden. Sonderübersetzungen sind lieferbar. Bitte fragen Sie bei uns an.

Wirkungsgrad

Der Wirkungsgrad der ATEK-Kegelradgetriebe beträgt 94-98%, abhängig von Drehzahl, Einbaulage, Abdichtung und Schmierstoffart. Die Wirkungsgrade beziehen sich auf die Nennleistungen der Getriebe.

Bei bestimmten Einbaulagen tauchen die Kegelräder voll in das Schmiermittel ein. Hier sind bei größeren Getrieben und hohen Umfangsgeschwindigkeiten der Räder die Planschverluste nicht zu vernachlässigen und bedingen Rücksprache mit ATEK.

Zu beachten ist, dass der Anlaufwirkungsgrad stets kleiner als der Betriebswirkungsgrad ist. Das entstehende, erhöhte Losbrechmoment ist bei der Auslegung der Antriebsleistung zu berücksichtigen.

Spielarme Ausführung

Standardmäßig haben die Kegelradgetriebe – abhängig von Getriebegröße und Übersetzung – ein Verdrehflankenspiel von 10 bis 30 Winkelminuten. Alle ATEK-Kegelradgetriebe können jedoch in spielarmer Ausführung geliefert werden.

Das Verdrehflankenspiel an der langsam laufenden Welle wird bei blockierter Antriebswelle auf einem Hebelarm von 100mm mit einer Messkraft von 3 % des Nennmoments gemessen und als Verdrehwinkel angegeben.

Folgende Werte sind mit Normalradsätzen einstellbar:

Ausführung S1: $i=1:1$ bis $2:1 < 6$ Winkelminuten

Ausführung S2: $i=3:1$ bis $6:1 < 10$ Winkelminuten

Engere Werte erfordern ausgesuchte, HPGS-verzahnnte oder geschliffene Radsätze – bitte anfragen (Ausführung S0).

Befestigungsseite

Um die Lage verschiedener Getriebemerkmale eindeutig zu bestimmen, sind die Seiten der Getriebe mit den Ziffern 1 bis 6 nummeriert. Diese Nummern finden sich in den einzelnen Datenblättern wieder.

Alle 6 Seiten der Getriebe sind bearbeitet und können als Befestigungsflächen benutzt werden. Das V350 hat serienmäßig an allen Getriebeseiten Befestigungsbohrungen im Gehäuse. Alle Flanschflächen haben serienmäßig immer Befestigungsbohrungen! Folgende Bestelloptionen stehen Ihnen zur Verfügung:

Code	Befestigungsbohrungen
0	nur in den Flanschflächen
9	an allen Gehäuseseiten ohne Flansch (Seiten 1, 2 und 4)
9G	an allen Gehäuseseiten mit Flansch (Seiten 3, 5 und 6)

ATEK bevel gearboxes are encased in robust cast metal housings and have hardened bevel gears pairs with spiral toothings and amply dimensioned rolling bearings. Spiral bevel gears have the significant benefit of very favourable meshing characteristics (high contact ratio). They are therefore especially well suited for operation under high load factors and when the highest smoothness of running and a high degree of transmission precision are required.

The curved teeth are more resistant to distortion than are straight or helical teeth. A further benefit is their relative insensitivity to elastic distortion of wheels, shafts and bearings. The gearboxes are thus able to transmit extreme shock loads. A total of twelve different standard versions are available, with a further 22 variations as multi-shaft gear-boxes. All gearboxes may be installed in any mounting position and may have mounting holes on all sides.

Transmission Ratios

Transmission ratios of 1-1.5-2-3-4-5 and 6:1 are available as standard. All transmission ratios are mathematically precise. The gears can be used for gearing down and gearing up. Special transmission ratios are available. Please contact us for details.

Efficiency

ATEK gearboxes are 94-98% efficient, depending on rpm, mounting position, sealing and type of lubrication.

The efficiency level refers to the nominal power output from the transmission. In certain mounting positions, the bevel gears are completely immersed in the lubricant. In this case, churning loss in larger gearboxes and at high circumferential velocities of the wheels can be considerable and ATEK should be consulted.

In general, it should be noted that starting efficiency is always lower than operating efficiency. The resulting increased breakaway torque should be taken into consideration when determining the driving power required.

Low-backlash version

For standard bevel gear units have – depending on gear size and ratio – a backlash of 10 to 30 angular minutes. Nevertheless all ATEK bevel gearboxes can be supplied in a low-backlash version.

When the drive shaft is locked, tooth backlash on the slowly-running shaft is measured on a 100mm lever arm with a measuring force of 3% of the rated torque and then is given as a torsion angle.

The following values can be set with standard gear sets.

Design S1: $i=1:1$ bis $2:1 < 6$ angular minutes

Design S2: $i=3:1$ bis $6:1 < 10$ angular minutes

Tighter values can be obtained from specially selected, HPGS-gear or ground gear sets – please ask (Design S0).

Mounting Side

To indicate clearly the positions of different gearbox features, the sides of the gearbox are numbered 1 to 6. These numbers can be found in the individual data sheets.

All six sides of the gearbox are machined and can be used as mounting surfaces. The flanges and neck flanges are fitted with threaded holes as standard equipment. The following ordering options are available:

Code	Mounting holes
0	only in the flange surfaces
9	on all gearbox sides without flanges
9G	on all gearbox sides with flange / neck flange

Vorzugsdrehrichtung

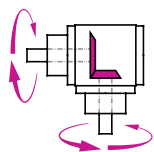

ATEK Kegelradgetriebe können grundsätzlich in beiden Drehrichtungen betrieben werden. Die Spiralrichtung eines Radsatzes bestimmt gemeinsam mit der Drehrichtung die inneren Lastverhältnisse des Getriebes. Wählt man die Drehrichtung des kleinen Rades entgegen seiner Spiralrichtung (Blickrichtung vom Wellenspiegel zur Getriebemitte), so wirkt die Axialkraft nach außen. Dadurch wird der Radsatz auseinander gedrückt und verursacht einen um 1 - 2 dBA geringeren Geräuschpegel. Bei ATEK wird das Ritzel als Linksspirale gefertigt, somit sollte die Vorzugsdrehrichtung rechts sein.

Schmierung

ATEK-Kegelradgetriebe werden mit Ölfüllung geliefert und sind unter normalen Betriebsbedingungen wartungsfrei. Bei extremen Anforderungen oder erhöhten Lebensdauerforderungen empfehlen wir Ölwechsel nach ca. 15.000 Betriebsstunden.

ATEK ist bestrebt für jeden Einsatzfall die besten Schmierstoffe auszuwählen und so die Lebensdauer der Getriebe zu optimieren. Entscheidend für die Wahl der Schmierstoffe sind die Umfangsgeschwindigkeit der Kegelräder, die zu übertragende Leistung und die Einsatzbedingungen.

Einen ungefähren Richtwert zur eingesetzten Schmierungsart kann den zwei Auswahldiagrammen und der Schmierstofftabelle entnommen werden.

Der Weg zur richtigen Schmierungsart erfolgt über zwei Auswahldiagramme und eine Schmierstofftabelle. Die Auswahldiagramme berücksichtigen das Katalog-Nennmoment und die Betriebsart des Getriebes mit 100% Einschaltdauer oder 30%/h Aussetzbetrieb.

Nach der Wahl der Betriebsart und unter Berücksichtigung der Betriebsbedingungen wird mit der Drehzahl der langsam laufenden Getriebewelle die Schmierstoffart festgelegt. Aus der darunter aufgeführten Schmierstofftabelle kann die Schmierungsart, die Notwendigkeit einer Getriebeentlüftung und das Getriebeöl abgelesen werden.

Die tatsächlich zum Einsatz kommende Schmierungsart wird für den spezifischen Anwendungsfall von uns festgelegt und kann von den Tabellenwerten abweichen!

Zur Auswahl stehen moderne synthetische Hochleistungs-Schmierstoffe. Für den Getriebeeinsatz in der Pharma- oder Lebensmittelindustrie können bewährte NOTOX-Schmierstoffe mit NSF-H1-Freigabe (USDA-H1) gewählt werden.

ATEK-Getriebe sind lebensdauer geschmiert. Schmierstoffmengen werden firmenintern für die Einbaulage festgelegt. Natürlich können auch biologisch abbaubare Öle oder Schmierstoffe für extreme Einsatzbedingungen geliefert werden. Hierzu bitten wir um Rückfragen bei ATEK.

Auch unter normalen Einsatzbedingungen kann wegen der geringen Konvektionsoberfläche die Getriebetemperatur über 50°C betragen. Überschreitet das Getriebe im Einsatz diese Temperatur, muss der mitgelieferte EntlüftungsfILTER eingesetzt werden, um einen Überdruck im Getriebe und damit eine Undichtigkeit des Getriebes zu vermeiden. Die Zufuhr von Frischluft ist sicherzustellen. Bei extremen Umgebungsbedingungen (Staub, Feuchtigkeit etc.) bitten wir um Rücksprache.

Bei Aussetzbetrieb oder anderen Einsatzbedingungen, die eine Erwärmung des Getriebes über 50°C nicht erwarten lassen, wird auf die Entlüftungsbohrung verzichtet.

Preferred rotational direction

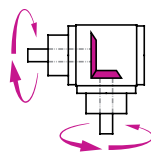

ATEK bevel gearboxes can normally be run in either rotational direction. The spiral direction of the gear set and the rotational direction used are key factors determining the forces evolved within the unit. In most instances permissible torque transmission can be maximized by using the gear pairing such that the driving gear rotates in the same direction as the spiralling. This arrangement creates a more favourable contact point which reduces gear distortion. This also reduces noise from the gear pairing by 1-2 dBA due to the fact that the axial forces caused by the spiral meshing push the gears apart. In ATEK bevel gear transmissions the pinion gear always has a left-handed spiral; accordingly, the large gear has a right-handed spiral.

Lubrication

ATEK bevel gearboxes are supplied oil-filled and are maintenance-free under normal operating conditions. With extreme requirements or increased demands on durability we recommend to change the oil after approx. 15,000 hours of operation.

ATEK is anxious to select the best lubricants for each case of application and in so doing optimizing the lifetime of the transmission. The peripheral speed of the bevel gears, the power that is to be transferred, and the operating conditions are crucial for the choice of the lubricant.

An approximate guideline value for the type of lubrication used can be found in the two selection diagrams and in the lubricant table.

The way to the correct type of lubrication is to be found using the two selection diagrams and the lubricant table. The selection diagrams consider the nominal moment, as taken from catalogue, and the operating mode of the transmission with 100% operating time or 30%/h intermittent operation. After the operating mode being selected and the operating conditions have been considered, the type of lubricant is determined by the number of revolutions of the slow running transmission shaft. From the lubricant table specified underneath this, the type of lubrication, the necessity for aeration of the transmission and the transmission oil can be seen.

The type of lubrication actually used is determined by us for the specific application and can differ from the values in the table!

Modern synthetic high-tech lubricants are available for choice. For transmission application in the Pharma or Foodstuffs industry, proven NOTOX lubricants with NSF release (USDA-H1) can be selected.

ATEK transmissions are lubricated for a lifetime. The amount of lubricant has been internally determined for each assembly position. Naturally, biological-degradable oils or lubricants for extreme operating conditions can be supplied. For this purpose please contact ATEK-Technik.

Also under normal operating conditions the transmission temperature can rise to over 50°C because of the small convection surface. If the transmission exceeds this temperature during use the included aeration filter must be fitted in order to avoid overpressure in the transmission and thus a leakage. Sufficient fresh air supply must be ensured. If the unit is intended for use under extreme ambient conditions (dust, moisture, etc.) please consult ATEK. With intermittent operation or other operating conditions in which a rise in temperature of the transmission to over 50°C is not expected, the aeration hole is not required.

Schmierung / Lubrication

Übersetzungen / Transmission Ratios $i = 1:1 - 6:1$

Umgebungstemperatur / Ambient temperature $-10\text{ °C} - +30\text{ °C}$

Einschaltdauer / Operating time 100% / h

n2 unter Berücksichtigung der maximal zulässigen Werte aus den Leistungstabellen wählen!
Choose n2 on the basis of the maximum allowable values of the performance tables!

n2 [1/min]	Getriebegröße / Size								
	065	090	120	140	160	200	230	260	350
200	A	A	A	A	A	A	A	A	B 0
300	A	A	A	A	A	A	B 0	B 0	B 0
400	A	A	A	A	A	B 0	B 0	B 0	B 0
500	A	A	A	A	B 0	B 0	B 0	B 1	B 1
600	A	A	A	B 0	B 0	B 0	B 1	B 1	B 1
700	A	A	B 0	B 0	B 0	B 1	B 1	B 1	B 1
800	A	B 0	B 0	B 0	B 0	B 1	B 1	B 1	B 1
900	A	B 0	B 0	B 0	B 1	B 1	B 1	B 1	B 1
1000	A	B 0	B 0	B 1	B 1	B 1	B 1	B 2	B 2
1100	A	B 0	B 0	B 1	B 1	B 1	B 2	B 2	B 2
1200	B 0	B 0	B 1	B 1	B 1	B 1	B 2	B 2	B 2
1500	B 0	B 0	B 1	B 1	B 1	B 2	B 2	B 2	C
1600	B 0	B 1	B 1	B 1	B 1	B 2	B 2	B 2	C
1700	B 0	B 1	B 1	B 1	B 2	B 2	B 2	C	C
1800	B 0	B 1	B 1	B 1	B 2	B 2	B 2	C	C
2200	B 0	B 1	B 1	B 2	B 2	C	C	C	C
3000	B 1	B 1	B 2	B 2	C	C	C	C	C
3400	B 1	B 2	B 2	B 2	C	C	C	C	C

Einschaltdauer / Operating time 30% / h

n2 unter Berücksichtigung der maximal zulässigen Werte aus den Leistungstabellen wählen!
Choose n2 on the basis of the maximum allowable values of the performance tables!

n2 [1/min]	Getriebegröße / Size								
	065	090	120	140	160	200	230	260	350
400	A	A	A	A	A	A	A	A	B 0
500	A	A	A	A	A	A	B 0	B 0	B 0
700	A	A	A	A	A	B 0	B 0	B 0	B 1
800	A	A	A	A	B 0	B 0	B 1	B 1	B 1
900	A	A	A	B 0	B 0	B 0	B 1	B 1	B 1
1000	A	A	B 0	B 0	B 0	B 1	B 1	B 1	B 2
1100	A	A	B 0	B 0	B 0	B 1	B 1	B 1	B 2
1200	A	A	B 0	B 0	B 0	B 1	B 1	B 2	B 2
1300	A	A	B 0	B 0	B 1	B 1	B 2	B 2	B 2
1400	A	B 0	B 0	B 0	B 1	B 1	B 2	B 2	C
1500	A	B 0	B 0	B 1	B 1	B 2	B 2	B 2	C
1700	A	B 0	B 0	B 1	B 1	B 2	B 2	C	C
1900	A	B 0	B 1	B 1	B 1	B 2	B 2	C	C
2000	B 0	B 0	B 1	B 1	B 2	B 2	C	C	C
2200	B 0	B 0	B 1	B 1	B 2	C	C	C	C
2300	B 0	B 1	B 1	B 1	B 2	C	C	C	C
2800	B 0	B 1	B 1	B 2	B 2	C	C	C	C
3000	B 0	B 1	B 2	B 2	C	C	C	C	C
3300	B 0	B 1	B 2	B 2	C	C	C	C	C

	Code	Schmierung / Lubrication	Entlüftung / Venting Filter	Viscosität / Viscosity ISO VG
Standard	A	Tauchschnierung / Dip lubrication	ohne / no	460
	B 0	Tauchschnierung / Dip lubrication	ohne / no	220
	B 1	Tauchschnierung / Dip lubrication	mit / yes	220
	B 2	Tauchschnierung / Dip lubrication	mit / yes	68
	C	Einspritzschmierung / Spray lubrication	mit / yes	68
NOTOX	F 00	Fettschnierung / Grease lubrication	ohne / no	00
	A	Tauchschnierung / Dip lubrication	ohne / no	460
	B 0	Tauchschnierung / Dip lubrication	ohne / no	220
	B 1	Tauchschnierung / Dip lubrication	mit / yes	220
	B 2	Tauchschnierung / Dip lubrication	mit / yes	68
	F 00	Fettschnierung / Grease lubrication	ohne / no	00

Lage der EntlüftungsfILTER

Bei den Schmierungsarten B1 und B2 wird das Getriebe mit einem EntlüftungsfILTER geliefert. Die möglichen Lagen des Filters entnehmen Sie bitte der untenstehenden Tabelle. In der Bestellbezeichnung wird angegeben, an welcher Getriebeseite der Filter montiert wird.

Z.B.: E4=Entlüftung an Seite 4. Erfolgt mit der Bestellung keine Angabe, wird die Lage des Entlüftungsfilters von ATEK festgelegt.

Position of Vent Filter

In lubrication types B1 and B2, the gearbox is supplied with a vent filter. The possible locations of the filter are given in the table below. When ordering, the customer should specify the side of the gearbox on which the filter should be installed.

E.G.: E4=vent on side 4. If no vent filter location is specified in the order, the location will be determined by ATEK.

		Einbaulage / Filter position					
		1	2	3	4	5	6
Typ/Type V Bauart / Model A0 - D0							
	E2	E1	E4	E2	E4	E4	
Typ/Type V Bauart / Model E0 - E0/HSD							
	E4	E4	E1	E2	E1	E2	
Typ/Type VS Bauart / Model B0 - D0							
	E2	E1	E4	E2	E4	E4	
Typ/Type VL / VLM Bauart / Model A0 - D0							
	E4	E4	E1	E2	E1	E2	
Typ/Type VL / VLM Bauart / Model E0 - E0/HSD							
	E4	E4	E1	E2	E1	E2	

Typ V

Kegelradgetriebe / Bevel Gearboxes

iN / ilst	n1 1/min	n2 1/min	kW Nm	Grösse / size									
				065	090	120	140	160	200	230	260	350	
1:1 - 6:1			P1Nt	1,60	3,80	6,20	10,00	15,00	26,00	34,00	42,00	90,00	
1:1	3000	3000	P1N	3,31	8,93	21,82	39,68						
			T2N	10,00	27,00	66,00	120,00						
	2400	2400	P1N	2,65	7,41	18,52	37,03	57,67					
			T2N	10,00	28,00	70,00	140,00	218,00					
	1500	1500	P1N	1,82	5,29	13,56	26,78	42,99	74,40	87,63	157,07	267,84	
			T2N	11,00	32,00	82,00	162,00	260,00	450,00	530,00	950,00	1620,00	
	1000	1000	P1N	1,32	3,75	10,14	20,28	31,96	56,21	71,65	115,73	210,53	
			T2N	12,00	34,00	92,00	184,00	290,00	510,00	650,00	1050,00	1910,00	
	750	750	P1N	1,07	3,06	8,51	16,20	25,63	45,88	60,76	96,72	195,92	
			T2N	13,00	37,00	103,00	196,00	310,00	555,00	735,00	1170,00	2370,00	
	500	500	P1N	0,83	2,20	6,34	11,46	18,19	34,17	45,19	72,75	155,41	
			T2N	15,00	40,00	115,00	208,00	330,00	620,00	820,00	1320,00	2820,00	
	250	250	P1N	0,47	1,21	3,39	5,92	9,64	19,56	26,73	42,44	94,52	
			T2N	17,00	44,00	123,00	215,00	350,00	710,00	970,00	1540,00	3440,00	
	50	50	P1N	0,10	0,28	0,72	1,21	2,09	4,13	7,00	9,64	24,47	
			T2N	18,00	50,00	130,00	220,00	380,00	750,00	1270,00	1750,00	4440,00	
				T2max	25,00	105,00	220,00	430,00	660,00	1090,00	1500,00	2310,00	5400,00
	1,5:1	3000	2000	P1N	2,20	5,51	13,45	24,91	40,78	72,75	99,20	189,58	
T2N				10,00	25,00	61,00	113,00	185,00	330,00	450,00	860,00		
2400		1600	P1N	1,76	4,59	11,46	22,22	36,15	63,49	91,35	158,72		
			T2N	10,00	26,00	65,00	126,00	205,00	360,00	518,00	900,00		
1500		1000	P1N	1,21	3,20	8,60	17,08	27,78	48,17	72,20	104,71	206,19	
			T2N	11,00	29,00	78,00	155,00	252,00	437,00	655,00	950,00	1870,00	
1000		667	P1N	0,88	2,35	6,32	12,87	20,59	37,13	56,21	77,19	188,55	
			T2N	12,00	32,00	86,00	175,00	280,00	505,00	765,00	1050,00	2560,00	
750		500	P1N	0,72	1,93	5,18	10,47	16,26	30,31	45,47	64,48	141,42	
			T2N	13,00	35,00	94,00	190,00	295,00	550,00	825,00	1170,00	2560,00	
500		333	P1N	0,55	1,36	3,85	7,34	11,56	22,57	33,79	47,72	112,63	
			T2N	15,00	37,00	105,00	200,00	315,00	615,00	920,00	1300,00	3070,00	
250		167	P1N	0,31	0,74	1,99	3,76	6,07	12,70	20,57	27,43	67,11	
			T2N	17,00	40,00	108,00	204,00	330,00	690,00	1120,00	1490,00	3650,00	
50		33	P1N	0,07	0,16	0,41	0,76	1,29	2,73	4,89	6,18	16,34	
			T2N	18,00	45,00	113,00	210,00	355,00	750,00	1330,00	1700,00	4500,00	
				T2max	25,00	80,00	169,00	358,00	650,00	980,00	1400,00	2100,00	5200,00
2:1		3000	1500	P1N	1,65	3,80	9,26	16,53	28,11	51,25	87,63	133,92	
	T2N			10,00	23,00	56,00	100,00	170,00	310,00	530,00	810,00		
	2400	1200	P1N	1,32	3,17	8,07	14,68	25,53	45,24	80,02	112,43		
			T2N	10,00	24,00	61,00	111,00	193,00	342,00	605,00	850,00		
	1500	750	P1N	0,91	2,23	6,03	11,41	20,25	35,13	59,11	78,53	200,06	
			T2N	11,00	27,00	73,00	138,00	245,00	425,00	715,00	950,00	2420,00	
	1000	500	P1N	0,66	1,71	4,46	8,38	14,88	27,56	45,19	57,87	155,41	
			T2N	12,00	31,00	81,00	152,00	270,00	500,00	820,00	1050,00	2820,00	
	750	375	P1N	0,54	1,32	3,55	6,86	11,57	22,32	36,79	48,36	129,37	
			T2N	13,00	32,00	86,00	166,00	280,00	540,00	890,00	1170,00	3130,00	
	500	250	P1N	0,41	0,94	2,54	4,96	8,27	16,81	26,73	35,27	94,52	
			T2N	15,00	34,00	92,00	180,00	300,00	610,00	970,00	1280,00	3430,00	
	250	125	P1N	0,23	0,50	1,35	2,62	4,41	9,37	16,88	20,12	54,15	
			T2N	17,00	36,00	98,00	190,00	320,00	680,00	1225,00	1460,00	3930,00	
	50	25	P1N	0,05	0,10	0,29	0,55	0,98	2,07	3,66	4,55	12,79	
			T2N	18,00	37,00	107,00	200,00	355,00	750,00	1330,00	1650,00	4640,00	
				T2max	25,00	80,00	169,00	320,00	650,00	980,00	1400,00	2100,00	5000,00
	3:1	3000	1000	P1N	1,10	2,54	6,39	12,12	20,94	46,29	44,09	85,97	
T2N				10,00	23,00	58,00	110,00	190,00	420,00	400,00	780,00		
2400		800	P1N	0,88	2,12	5,56	11,46	17,81	39,24	39,68	72,39	160,48	
			T2N	10,00	24,00	63,00	130,00	202,00	445,00	450,00	821,00	1820,00	
1500		500	P1N	0,61	1,49	4,08	8,05	12,68	28,38	29,76	49,60	122,35	
			T2N	11,00	27,00	74,00	146,00	230,00	515,00	540,00	900,00	2220,00	
1000		333	P1N	0,44	1,14	3,01	5,87	8,99	20,37	23,33	36,34	96,26	
			T2N	12,00	31,00	82,00	160,00	245,00	555,00	635,00	990,00	2620,00	

Selecting Gearsize

iN / ilst	n1 1/min	n2 1/min	kW Nm	Grösse / size									
				065	090	120	140	160	200	230	260	350	
3:1	750	250	P1N	0,33	0,88	2,40	4,60	6,89	15,98	19,29	28,93	81,29	
			T2N	12,00	32,00	87,00	167,00	250,00	580,00	700,00	1050,00	2950,00	
	500	167	P1N	0,24	0,63	1,66	3,20	4,79	11,04	14,07	20,43	59,34	
			T2N	13,00	34,00	90,00	174,00	260,00	600,00	765,00	1110,00	3230,00	
	250	83	P1N	0,12	0,33	0,87	1,62	2,56	5,76	7,58	11,16	34,26	
			T2N	13,00	36,00	95,00	177,00	280,00	630,00	825,00	1220,00	3730,00	
	50	17	P1N	0,03	0,07	0,21	0,34	0,57	1,29	1,63	2,55	7,79	
			T2N	14,00	37,00	110,00	180,00	305,00	690,00	870,00	1360,00	4240,00	
	T2max				23,00	70,00	155,00	280,00	457,00	910,00	1300,00	1940,00	4500,00
	4:1	3000	750	P1N		1,90	4,96	8,51	14,88	28,93	36,37	57,87	
T2N					23,00	60,00	103,00	180,00	350,00	440,00	700,00		
2400		600	P1N		1,65	4,43	7,34	13,23	26,45	32,74	51,58	113,75	
			T2N		25,00	67,00	111,00	200,00	400,00	495,00	780,00	1720,00	
1500		375	P1N		1,12	3,06	4,96	9,09	18,81	24,80	37,20	78,95	
			T2N		27,00	74,00	120,00	220,00	455,00	600,00	900,00	1910,00	
1000		250	P1N		0,85	2,18	3,75	6,61	13,36	18,60	28,93	58,14	
			T2N		31,00	79,00	136,00	240,00	485,00	675,00	1050,00	2110,00	
750		187,5	P1N		0,66	1,69	3,06	5,17	10,54	15,19	22,73	47,95	
			T2N		32,00	82,00	148,00	250,00	510,00	735,00	1100,00	2320,00	
500		125	P1N		0,47	1,16	2,12	3,58	7,23	10,95	16,26	34,72	
			T2N		34,00	84,00	154,00	260,00	525,00	795,00	1180,00	2520,00	
250		62,5	P1N		0,25	0,60	1,12	1,86	3,79	5,99	8,61	19,43	
			T2N		36,00	87,00	162,00	270,00	550,00	870,00	1250,00	2820,00	
50		12,5	P1N		0,05	0,12	0,23	0,39	0,80	1,35	1,82	4,17	
			T2N		37,00	90,00	170,00	280,00	580,00	980,00	1320,00	3030,00	
T2max				70,00	155,00	280,00	422,00	860,00	1300,00	1940,00	3500,00		
5:1		3000	600	P1N		1,52	3,97	6,61	11,90	19,84	33,73	46,29	
	T2N				23,00	60,00	100,00	180,00	300,00	510,00	700,00		
	2400	480	P1N		1,32	3,44	5,56	10,48	17,99	29,10	40,21	78,83	
			T2N		25,00	65,00	105,00	198,00	340,00	550,00	760,00	1490,00	
	1500	300	P1N		0,89	2,38	3,80	7,11	12,57	21,00	29,10	56,54	
			T2N		27,00	72,00	115,00	215,00	380,00	635,00	880,00	1710,00	
	1000	200	P1N		0,68	1,76	2,73	4,96	9,26	15,76	21,82	42,33	
			T2N		31,00	80,00	124,00	225,00	420,00	715,00	990,00	1920,00	
	750	150	P1N		0,53	1,42	2,15	3,97	7,27	12,73	18,19	35,88	
			T2N		32,00	86,00	130,00	240,00	440,00	770,00	1100,00	2170,00	
	500	100	P1N		0,37	0,98	1,50	2,76	5,18	9,15	13,23	26,67	
			T2N		34,00	89,00	136,00	250,00	470,00	830,00	1200,00	2420,00	
	250	50	P1N		0,20	0,51	0,79	1,49	2,78	5,07	7,11	16,09	
			T2N		36,00	92,00	143,00	270,00	505,00	920,00	1290,00	2920,00	
	50	10	P1N		0,04	0,10	0,17	0,32	0,58	1,09	1,47	3,56	
			T2N		37,00	95,00	150,00	290,00	525,00	990,00	1330,00	3230,00	
	T2max				60,00	140,00	250,00	420,00	860,00	1200,00	1910,00	3500,00	
	6:1	3000	600	P1N		1,25	2,95	5,18	7,09	11,45	20,17	27,27	
T2N					23,00	54,00	94,00	129,00	208,00	366,00	495,00		
2400		480	P1N		1,09	2,53	4,58	5,98	9,60	18,08	23,12	56,88	
			T2N		25,00	57,00	104,00	136,00	218,00	410,00	524,00	1290,00	
1500		300	P1N		0,74	1,75	2,95	3,95	6,54	13,50	16,36	41,61	
			T2N		27,00	64,00	107,00	143,00	237,00	490,00	594,00	1510,00	
1000		200	P1N		0,53	1,22	2,06	3,01	4,74	9,92	12,93	31,41	
			T2N		29,00	66,00	112,00	164,00	258,00	540,00	702,00	1710,00	
750		150	P1N		0,40	0,94	1,61	2,43	3,98	7,78	10,91	24,25	
			T2N		29,00	68,00	117,00	176,00	289,00	565,00	792,00	1760,00	
500		100	P1N		0,27	0,63	1,09	1,72	2,79	5,42	8,06	16,72	
			T2N		29,00	69,00	119,00	187,00	304,00	590,00	878,00	1820,00	
250		50	P1N		0,14	0,33	0,56	0,92	1,44	2,82	4,35	9,28	
			T2N		30,00	71,00	121,00	199,00	311,00	610,00	940,00	2020,00	
50		10	P1N		0,03	0,06	0,11	0,18	0,28	0,57	0,87	1,95	
			T2N		33,00	66,00	120,00	197,00	306,00	625,00	951,00	2120,00	
T2max				50,00	120,00	200,00	350,00	625,00	1000,00	1730,00	2300,00		

Typ VS

Kegelradgetriebe / Bevel Gearboxes

iN / ilst	n1 1/min	n2 1/min	kW Nm	Größe / Size							
				090	120	140	160	200	230	260	350
1,5:1 - 2:1			P1Nt	3,80	6,20	10,00	15,00	26,00			
1,5:1	3000	2000	P1N	5,51	13,45	24,91	40,78	72,75	auf Anfrage	189,58	auf Anfrage
			T2N	25,00	61,00	113,00	185,00	330,00		860,00	
	2400	1600	P1N	4,59	11,46	22,22	36,15	63,49		158,72	
			T2N	26,00	65,00	126,00	205,00	360,00		900,00	
	1500	1000	P1N	3,20	8,60	17,08	27,78	48,17		104,71	
			T2N	29,00	78,00	155,00	252,00	437,00		950,00	
	1000	667	P1N	2,35	6,32	12,87	20,59	37,13		73,50	
			T2N	32,00	86,00	175,00	280,00	505,00		1000,00	
	750	500	P1N	1,93	5,18	10,47	16,26	30,31		55,11	
			T2N	35,00	94,00	190,00	295,00	550,00		1000,00	
	500	333	P1N	1,36	3,70	7,34	11,56	22,02		36,70	
			T2N	37,00	100,00	200,00	315,00	600,00		1000,00	
	250	167	P1N	0,74	1,84	3,76	6,07	11,04		18,40	
			T2N	40,00	100,00	204,00	330,00	600,00		1000,00	
	50	33	P1N	0,15	0,37	0,76	1,29	2,18		3,64	
			T2N	40,00	100,00	210,00	355,00	600,00		1000,00	
				T2max	40,00	100,00	210,00	360,00	600,00		1000,00
	2:1	3000	1500	P1N	3,80	9,26	16,53	28,11	51,25		133,92
T2N				23,00	56,00	100,00	170,00	310,00		810,00	
2400		1200	P1N	3,17	8,07	14,68	25,53	45,24		112,43	
			T2N	24,00	61,00	111,00	193,00	342,00		850,00	
1500		750	P1N	2,23	6,03	11,41	20,25	35,13		78,53	
			T2N	27,00	73,00	138,00	245,00	425,00		950,00	
1000		500	P1N	1,65	4,40	8,38	14,88	27,56		57,87	
			T2N	30,00	80,00	152,00	270,00	500,00		1050,00	
750		375	P1N	1,24	3,30	6,86	11,57	21,90		48,36	
			T2N	30,00	80,00	166,00	280,00	530,00		1170,00	
500		250	P1N	0,82	2,20	4,96	8,27	14,60		33,07	
			T2N	30,00	80,00	180,00	300,00	530,00		1200,00	
250		125	P1N	0,41	1,10	2,48	4,41	7,30		16,53	
			T2N	30,00	80,00	180,00	320,00	530,00		1200,00	
50		25	P1N	0,08	0,22	0,50	0,88	1,46		3,31	
			T2N	30,00	80,00	180,00	320,00	530,00		1200,00	
				T2max	30,00	80,00	180,00	320,00	530,00		1200,00

Selecting Gearsize

Typ VL + VLM

Kegelradgetriebemotoren / Bevel Gearmotors

P1 kW	n2 1/min	T2 Nm	T2N Nm	T2max Nm	Typ type	ilst	Motor motor
0,12	1340	0,81	11	25	VLM 065	1	063A-4
	893	1,22	11	25	VLM 065	1,5	063A-4
	670	1,62	11	25	VLM 065	2	063A-4
	593	1,84	13	25	VLM 065	1,5	063B-6
	447	2,44	11	23	VLM 065	3	063A-4
	445	2,45	13	25	VLM 065	2	063B-6
	296	3,68	12	23	VLM 065	3	063B-6
0,18	2680	0,61	10	25	VLM 065	1	063A-2
	1787	0,91	10	25	VLM 065	1,5	063A-2
	1340	1,22	10	25	VLM 065	1	063B-4
	893	1,83	10	25	VLM 065	1,5	063B-4
	670	2,44	10	25	VLM 065	2	063B-4
	593	2,75	10	25	VLM 065	1,5	071A-6
	450	3,63	11	23	VLM 065	3	063B-4
	446	3,66	11	25	VLM 065	3	063B-4
	445	3,67	10	25	VLM 065	2	071A-6
	335	4,87	27	70	VLM 090	4	063B-4
	296	5,52	11	23	VLM 065	3	071A-6
	296	5,5	31	70	VLM 090	3	071A-6
	268	6,09	27	60	VLM 090	5	063B-4
	224	7,29	25	50	VLM 090	6	063B-4
	222	7,34	31	70	VLM 090	4	071A-6
	178	9,17	31	60	VLM 090	5	071A-6
	167	9,75	32	70	VLM 090	4	080A-8
	148	11,03	29	50	VLM 090	6	071A-6
	134	12,19	32	60	VLM 090	5	080A-8
	112	14,58	30	50	VLM 090	6	080A-8
0,25	2700	0,84	10	25	VLM 065	1	063B-2
	1800	1,26	10	25	VLM 065	1,5	063B-2
	1350	1,68	10	25	VLM 065	1	071A-4
	900	2,52	29	40	VLM 090	1,5	071A-4
	890	2,55	10	25	VLM 065	1	071B-6
	675	3,36	10	25	VLM 065	2	071A-4
	593	3,82	32	40	VLM 090	1,5	071B-6
	540	4,2	23	60	VLM 090	5	063B-2
	450	5,04	11	25	VLM 065	3	071A-4
	450	5,04	27	70	VLM 090	3	071A-4
	445	5,1	10	25	VLM 065	2	071B-6
	337	6,72	27	70	VLM 090	4	071A-4
	296	7,65	31	70	VLM 090	3	071B-6
	270	8,4	27	60	VLM 090	5	071A-4
	225	10,08	25	50	VLM 090	6	071A-4
	222	10,19	31	70	VLM 090	4	071B-6
	178	12,74	31	60	VLM 090	5	071B-6
	167	13,54	32	70	VLM 090	4	080B-8
	148	15,33	29	50	VLM 090	6	071B-6
	134	16,93	32	60	VLM 090	5	080B-8
112	20,25	30	50	VLM 090	6	080B-8	
0,37	2800	1,2	10	25	VLM 065	1	071A-2
	1866	1,8	25	40	VLM 090	1,5	071A-2
	1400	2,4	10	25	VLM 065	2	071A-2
	1350	2,49	10	25	VLM 065	1	071B-4
	933	3,6	10	23	VLM 065	3	071A-2
	933	3,6	23	70	VLM 090	3	071A-2
	900	3,73	29	40	VLM 090	1,5	071B-4

P1 kW	n2 1/min	T2 Nm	T2N Nm	T2max Nm	Typ type	ilst 0	Motor motor
0,37	700	4,8	23	70	VLM 090	4	071A-2
	675	4,97	10	25	VLM 065	2	071B-4
	675	4,97	27	30	VLM 090	2	071B-4
	600	5,59	32	40	VLM 090	1,5	080A-6
	560	5,99	23	60	VLM 090	5	071A-2
	450	7,46	27	70	VLM 090	3	071B-4
	337	9,95	27	70	VLM 090	4	071B-4
	300	11,19	31	70	VLM 090	3	080A-6
	270	12,43	27	60	VLM 090	5	071B-4
	225	14,92	31	70	VLM 090	4	080A-6
	225	14,92	25	50	VLM 090	6	071B-4
	180	18,65	31	60	VLM 090	5	080A-6
	170	19,75	82	155	VLM 120	4	090S-8
	150	22,38	29	50	VLM 090	6	080A-6
	136	24,68	86	140	VLM 120	5	090S-8
114	29,45	69	118	VLM 120	6	090S-8	
0,55	2810	1,78	10	25	VLM 065	1	071B-2
	1873	2,66	10	23	VLM 065	1,5	071B-2
	1873	2,66	25	40	VLM 090	1,5	071B-2
	1405	3,55	10	25	VLM 065	2	071B-2
	1360	3,67	32	105	VLM 090	1	080A-4
	936	5,33	10	23	VLM 065	3	071B-2
	936	5,33	23	70	VLM 090	3	071B-2
	906	5,5	29	40	VLM 090	1,5	080A-4
	900	5,54	34	105	VLM 090	1	080B-6
	702	7,1	23	70	VLM 090	4	071B-2
	680	7,34	27	30	VLM 090	2	080A-4
	600	8,32	32	40	VLM 090	1,5	080B-6
	562	8,88	23	60	VLM 090	5	071B-2
	453	11,01	27	70	VLM 090	3	080A-4
	340	14,68	27	70	VLM 090	4	080A-4
	300	16,63	31	70	VLM 090	3	080B-6
	272	18,35	72	140	VLM 120	5	080A-4
	227	21,98	25	50	VLM 090	6	080A-4
225	22,18	31	70	VLM 090	4	080B-6	
180	27,72	31	60	VLM 090	5	080B-6	
172	28,93	82	155	VLM 120	4	090L-8	
150	33,27	67	120	VLM 120	6	080B-6	
138	36,16	86	140	VLM 120	5	090L-8	
115	43,39	69	120	VLM 120	6	090L-8	
0,75	2820	2,41	27	105	VLM 090	1	080A-2
	1880	3,62	25	40	VLM 090	1,5	080A-2
	1410	4,83	23	30	VLM 090	2	080A-2
	1360	5	32	105	VLM 090	1	080B-4
	940	7,24	23	70	VLM 090	3	080A-2
	906	7,5	29	40	VLM 090	1,5	080B-4
	705	9,65	23	70	VLM 090	4	080A-2
	680	10,01	27	30	VLM 090	2	080B-4
	606	11,22	86	100	VLM 120	1,5	090S-6
	564	12,06	27	60	VLM 090	5	080A-2
	453	15,01	27	70	VLM 090	3	080B-4
	340	20,01	27	70	VLM 090	4	080B-4
	303	22,43	82	155	VLM 120	3	090S-6
	272	25,02	72	140	VLM 120	5	080B-4
	227	29,98	79	155	VLM 120	4	090S-6

Typ VL + VLM

Kegelradgetriebemotoren/Bevel Gearmotors

P1 kW	n2 1/min	T2 Nm	T2N Nm	T2max Nm	Typ type	ilst 0	Motor motor	
0,75	227	29,98	64	120	VLM 120	6	080B-4	
	182	37,39	80	140	VLM 120	5	090S-6	
	172	39,45	82	155	VLM 120	4	100LA-8	
	152	44,77	67	113	VLM 120	6	090S-6	
	138	49,31	86	140	VLM 120	5	100LA-8	
	115	59,17	69	118	VLM 120	6	100LA-8	
1,1	2820	3,54	27	105	VLM 090	1	080B-2	
	1880	5,31	25	40	VLM 090	1,5	080B-2	
	1410	7,08	23	30	VLM 090	2	080B-2	
	1380	7,23	82	220	VLM 120	1	090S-4	
	940	10,62	23	70	VLM 090	3	080B-2	
	920	10,85	78	100	VLM 120	1,5	090S-4	
	910	10,97	92	220	VLM 120	1	090L-6	
	705	14,16	23	70	VLM 090	4	080B-2	
	690	14,46	73	80	VLM 120	2	090S-4	
	606	16,45	86	100	VLM 120	1,5	090L-6	
	564	17,69	60	140	VLM 120	5	080B-2	
	460	21,7	74	155	VLM 120	3	090S-4	
	345	28,93	74	155	VLM 120	4	090S-4	
	303	32,9	82	155	VLM 120	3	090L-6	
	276	36,16	72	140	VLM 120	5	090S-4	
	230	43,39	87	155	VLM 120	3	100LB-8	
	230	43,39	64	120	VLM 120	6	090S-4	
	227	43,87	79	155	VLM 120	4	090L-6	
	182	54,83	80	140	VLM 120	5	090L-6	
	172	57,85	82	155	VLM 120	4	100LB-8	
	152	65,66	67	120	VLM 120	6	090L-6	
	138	72,32	86	140	VLM 120	5	100LB-8	
	115	86,78	118	200	VLM 140	6	100LB-8	
	1,5	2840	4,79	66	220	VLM 120	1	090S-2
1893		7,19	61	100	VLM 120	1,5	090S-2	
1420		9,58	56	80	VLM 120	2	090S-2	
1380		9,86	82	220	VLM 120	1	090L-4	
946		14,38	58	155	VLM 120	3	090S-2	
920		14,79	78	100	VLM 120	1,5	090L-4	
710		19,17	60	155	VLM 120	4	090S-2	
690		19,72	73	80	VLM 120	2	090L-4	
613		22,19	78	100	VLM 120	1,5	100LA-6	
568		23,96	60	140	VLM 120	5	090S-2	
460		29,58	74	155	VLM 120	3	090L-4	
345		39,45	74	155	VLM 120	4	090L-4	
306		44,38	82	155	VLM 120	3	100LA-6	
276		49,31	72	140	VLM 120	5	090L-4	
230		59,17	79	155	VLM 120	4	100LA-6	
230		59,17	64	120	VLM 120	6	090L-4	
184		73,96	80	140	VLM 120	5	100LA-6	
175		77,76	82	155	VLM 120	4	112M-8	
154		88,37	113	200	VLM 140	6	100LA-6	
140		97,21	130	250	VLM 140	5	112M-8	
117		116,31	118	200	VLM 140	6	112M-8	
2,2		2840	7,03	66	220	VLM 120	1	090L-2
		1893	10,54	61	100	VLM 120	1,5	090L-2
		1420	14,06	56	80	VLM 120	2	090L-2
	1410	14,16	82	220	VLM 120	1	100LA-4	
	946	21,08	58	155	VLM 120	3	090L-2	
	940	21,23	78	100	VLM 120	1,5	100LA-4	
	710	28,11	60	155	VLM 120	4	090L-2	
	705	28,31	73	80	VLM 120	2	100LA-4	
	626	31,85	80	100	VLM 120	1,5	112M-6	

P1 kW	n2 1/min	T2 Nm	T2N Nm	T2max Nm	Typ type	ilst 0	Motor motor	
2,2	568	35,14	60	140	VLM 120	5	090L-2	
	470	42,47	74	155	VLM 120	3	100LA-4	
	352	56,62	74	155	VLM 120	4	100LA-4	
	313	63,7	82	155	VLM 120	3	112M-6	
	282	70,78	72	140	VLM 120	5	100LA-4	
	235	84,93	136	280	VLM 140	4	112M-6	
	235	84,93	108	200	VLM 140	6	100LA-4	
	188	106,17	124	250	VLM 140	5	112M-6	
	177	112,77	148	280	VLM 140	4	132SB-8	
	157	127,13	165	200	VLM 160	6	112M-6	
	141	141,56	240	420	VLM 160	5	132SB-8	
	118	169,15	178	200	VLM 160	6	132SB-8	
	3,0	2850	9,55	66	220	VLM 120	1	100L-2
		1900	14,33	61	100	VLM 120	1,5	100L-2
1425		19,1	56	80	VLM 120	2	100L-2	
1410		19,3	82	220	VLM 120	1	100LB-4	
950		28,65	58	155	VLM 120	3	100L-2	
940		28,95	78	100	VLM 120	1,5	100LB-4	
712		38,2	60	155	VLM 120	4	100L-2	
705		38,61	73	80	VLM 120	2	100LB-4	
633		42,98	175	210	VLM 140	1,5	132SB-6	
570		47,75	60	140	VLM 120	5	100L-2	
475		57,3	152	180	VLM 140	2	132SB-6	
470		57,91	74	155	VLM 120	3	100LB-4	
352		77,21	74	155	VLM 120	4	100LB-4	
316		85,95	160	280	VLM 140	3	132SB-6	
282		96,52	115	250	VLM 140	5	100LB-4	
237		114,6	136	280	VLM 140	4	132SB-6	
235		115,82	145	350	VLM 160	6	100LB-4	
190		143,25	225	420	VLM 160	5	132SB-6	
177	153,34	250	422	VLM 160	4	132MB-8		
142	191,67	240	420	VLM 160	5	132MB-8		
4,0	2860	12,69	66	220	VLM 120	1	112M-2	
	1906	19,03	61	100	VLM 120	1,5	112M-2	
	1430	25,38	56	80	VLM 120	2	112M-2	
	1420	25,56	82	220	VLM 120	1	112M-4	
	953	38,07	58	155	VLM 120	3	112M-2	
	946	38,33	78	100	VLM 120	1,5	112M-4	
	715	50,76	60	155	VLM 120	4	112M-2	
	710	51,11	73	80	VLM 120	2	112M-4	
	633	57,3	175	210	VLM 140	1,5	132MA-6	
	572	63,44	100	250	VLM 140	5	112M-2	
	475	76,4	152	180	VLM 140	2	132MA-6	
	473	76,67	74	155	VLM 120	3	112M-4	
	355	102,23	120	280	VLM 140	4	112M-4	
	355	102,23	220	422	VLM 160	4	112M-4	
	316	114,6	160	280	VLM 140	3	132MA-6	
	284	127,78	215	420	VLM 160	5	112M-4	
	237	152,8	240	422	VLM 160	4	132MA-6	
	190	191	225	420	VLM 160	5	132MA-6	
177	204,45	510	860	VLM 200	4	160MA-8		
142	255,56	440	860	VLM 200	5	160MA-8		
5,5	2900	17,33	120	430	VLM 140	1	132SA-2	
	1933	25,99	113	210	VLM 140	1,5	132SA-2	
	1450	34,41	100	180	VLM 140	2	132SA-2	
	1430	34,89	162	430	VLM 140	1	132SB-4	

Selecting Gearsize

P1 kW	n2 1/min	T2 Nm	T2N Nm	T2max Nm	Typ type	ilst 0	Motor motor
5,5	966	51,62	110	280	VLM 140	3	132SA-2
	953	52,34	155	210	VLM 140	1,5	132SB-4
	950	52,53	184	430	VLM 140	1	132MB-6
	715	69,79	138	180	VLM 140	2	132SB-4
	633	78,79	175	210	VLM 140	1,5	132MB-6
	580	86,03	100	250	VLM 140	5	132SA-2
	476	104,68	146	280	VLM 140	3	132SB-4
	476	104,68	230	457	VLM 160	3	132SB-4
	357	139,58	220	422	VLM 160	4	132SB-4
	316	157,58	160	280	VLM 140	3	132MB-6
	316	157,58	245	457	VLM 160	3	132MB-6
	286	174,47	215	420	VLM 160	5	132SB-4
	238	209,37	580	910	VLM 200	3	160LA-8
	237	210,1	240	422	VLM 160	4	132MB-6
	190	262,63	420	860	VLM 200	5	132MB-6
	178	279,15	510	860	VLM 200	4	160LA-8
	143	348,94	440	860	VLM 200	5	160LA-8
119	418,73	565	1000	VLM 230	6	160LA-8	
7,5	2900	23,46	120	430	VLM 140	1	132SB-2
	1933	35,2	113	210	VLM 140	1,5	132SB-2
	1430	47,58	162	430	VLM 140	1	132MB-4
	966	70,39	110	280	VLM 140	3	132SB-2
	953	71,37	155	210	VLM 140	1,5	132MB-4
	715	95,17	138	180	VLM 140	2	132MB-4
	640	106,32	505	600	VLM 200	1,5	160MB-6
	580	117,32	180	420	VLM 160	5	132SB-2
	480	141,76	500	530	VLM 200	2	160MB-6
	476	142,75	146	280	VLM 140	3	132MB-4
	476	142,75	230	457	VLM 160	3	132MB-4
	357	190,33	220	422	VLM 160	4	132MB-4
	320	212,64	555	910	VLM 200	3	160MB-6
	286	237,92	380	860	VLM 200	5	132MB-4
	240	283,52	485	860	VLM 200	4	160MB-6
	192	354,39	420	860	VLM 200	5	160MB-6
	180	378,02	510	860	VLM 200	4	160LB-8
160	425,27	540	1000	VLM 230	6	160MB-6	
144	472,53	770	1200	VLM 230	5	160LB-8	
144	472,53	1100	1910	VLM 260	5	160LB-8	
9,0	2910	28,06	120	430	VLM 140	1	132MA-2
	1940	42,09	113	210	VLM 140	1,5	132MA-2
	1430	57,1	162	430	VLM 140	1	132MC-4
	1430	57,1	260	660	VLM 160	1	132MC-4
	970	84,18	110	280	VLM 140	3	132MA-2
	970	84,18	190	457	VLM 160	3	132MA-2
	953	85,65	155	210	VLM 140	1,5	132MC-4
	953	85,65	252	360	VLM 160	1,5	132MC-4
	727	112,24	180	422	VLM 160	4	132MA-2
	715	114,2	138	180	VLM 140	2	132MC-4
	715	114,2	245	320	VLM 160	2	132MC-4
	582	140,3	180	420	VLM 160	5	132MA-2
	476	171,3	230	457	VLM 160	3	132MC-4
	357	228,4	220	422	VLM 160	4	132MC-4
	286	285,5	380	860	VLM 200	5	132MC-4
	238	342,59	490	1000	VLM 230	6	132MC-4
	11,0	1940	51,44	330	600	VLM 200	1,5
1465		68,12	450	1090	VLM 200	1	160MB-4
976		102,18	437	600	VLM 200	1,5	160MB-4
732		136,24	425	530	VLM 200	2	160MB-4

P1 kW	n2 1/min	T2 Nm	T2N Nm	T2max Nm	Typ type	ilst 0	Motor motor	
11,0	640	155,93	505	600	VLM 200	1,5	160LA-6	
	582	171,47	300	860	VLM 200	5	160MA-2	
	488	204,36	515	910	VLM 200	3	160MB-4	
	366	272,48	455	860	VLM 200	4	160MB-4	
	320	311,87	555	910	VLM 200	3	160LA-6	
	293	340,61	380	860	VLM 200	5	160MB-4	
	240	415,82	485	860	VLM 200	4	160LA-6	
	182	546,84	735	1300	VLM 230	4	180L-8	
	192	519,78	770	1200	VLM 230	5	160LA-6	
	192	519,78	990	1910	VLM 260	5	160LA-6	
	182	546,84	1100	1940	VLM 260	4	180L-8	
	146	683,54	1100	1910	VLM 260	5	180L-8	
	15,0	1953	69,67	330	600	VLM 200	1,5	160MB-2
		1465	92,89	450	1090	VLM 200	1	160LA-4
		976	139,34	437	600	VLM 200	1,5	160LA-4
		732	185,78	425	530	VLM 200	2	160LA-4
		646	210,44	505	600	VLM 200	1,5	180L-6
586		232,23	300	860	VLM 200	5	160MB-2	
488		278,68	515	910	VLM 200	3	160LA-4	
366		371,57	455	860	VLM 200	4	160LA-4	
323		420,89	555	910	VLM 200	3	180L-6	
293		464,46	635	1200	VLM 230	5	160LA-4	
242		561,18	675	1300	VLM 230	4	180L-6	
488		278,67	366	1000	VLM 230	6	160MB-2	
293		464,46	880	1910	VLM 260	5	160LA-4	
242		561,19	1050	1940	VLM 260	4	180L-6	
194		701,48	990	1910	VLM 260	5	180L-6	
182		745,68	1100	1940	VLM 260	4	200LB-8	
146		932,11	1100	1910	VLM 260	5	200LB-8	
18,5	1960	85,63	330	600	VLM 200	1,5	160L-2	
	1470	114,18	450	1090	VLM 200	1	180M-4	
	980	171,27	437	600	VLM 200	1,5	180M-4	
	975	172,14	1050	2310	VLM 260	1	200LA-6	
	735	228,36	425	530	VLM 200	2	180M-4	
	650	258,22	1050	1000	VLM 260	1,5	200LA-6	
	588	285,44	300	860	VLM 200	5	160L-2	
	490	342,53	515	910	VLM 200	3	180M-4	
	367	456,71	455	860	VLM 200	4	180M-4	
	490	342,53	366	1000	VLM 230	6	160L-2	
	294	570,88	635	1200	VLM 230	5	180M-4	
	325	516,43	635	1300	VLM 230	3	200LA-6	
	325	516,43	990	1940	VLM 260	3	200LA-6	
	294	570,89	880	1910	VLM 260	5	180M-4	
	243	688,58	1050	1940	VLM 260	4	200LA-6	
	195	860,72	990	1910	VLM 260	5	200LA-6	
	22	1470	135,78	450	1090	VLM 200	1	180L-4
980		203,67	437	600	VLM 200	1,5	180L-4	
735		271,56	425	530	VLM 200	2	180L-4	
650		307,07	1050	1000	VLM 260	1,5	200LB-6	
490		407,34	515	910	VLM 200	3	180L-4	
367		543,12	600	1300	VLM 230	4	180L-4	
590		338,29	510	1200	VLM 230	5	180M-2	
367		543,12	900	1940	VLM 260	4	180L-4	
325		614,14	990	1940	VLM 260	3	200LB-6	
294		678,89	880	1910	VLM 260	5	180L-4	
243		818,85	1050	1940	VLM 260	4	200LB-6	
30		737	369,05	440	1300	VLM 230	4	200L-2
		1470	185,15	950	2310	VLM 260	1	200LB-4
		980	277,73	950	1000	VLM 260	1,5	200LB-4
		735	370,31	950	1200	VLM 260	2	200LB-4
		490	555,46	900	1940	VLM 260	3	200LB-4
		367	740,61	900	1940	VLM 260	4	200LB-4

Typ V 065

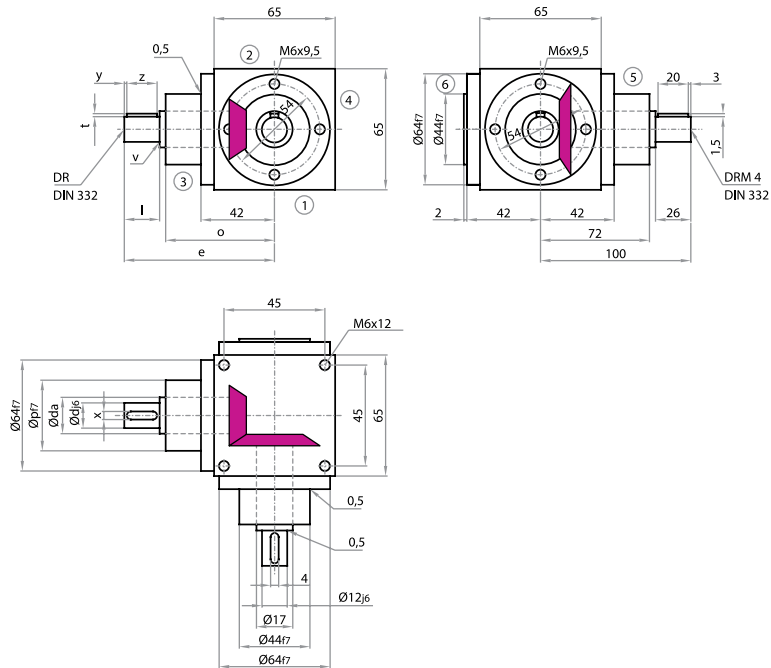

Bauart / Model

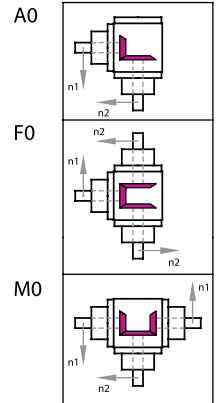

Achtung: Standardbefestigungsgewinde im Gehäuse nur an den Seiten 1, 2 & 4.
 Alternativ auch an den Seiten 3, 5 & 6 im Rastermaß 54x54 möglich.
Note: Standard fastening thread in the housing only on sides 1, 2 & 4.
 Alternatively, also possible in the grid dimension of 54x54 on sides 3, 5 & 6.

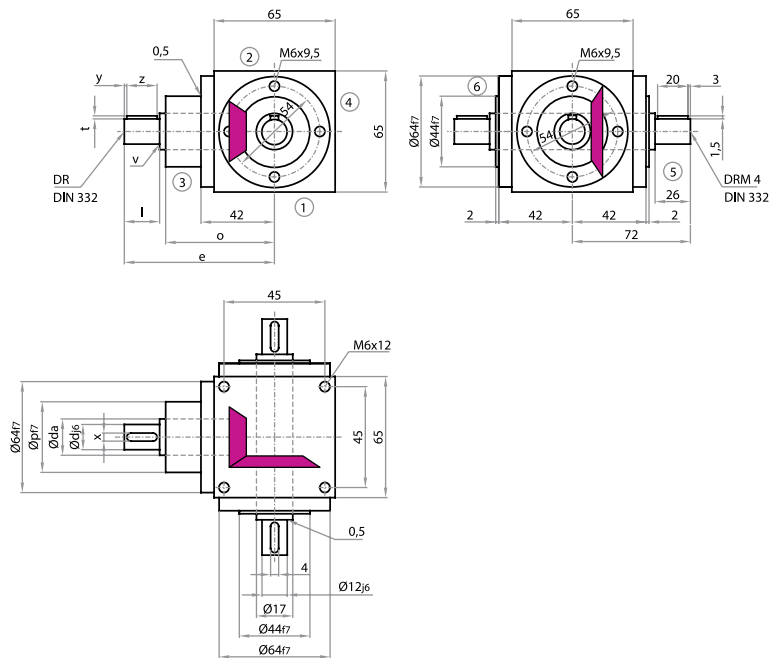

Bauart / Model

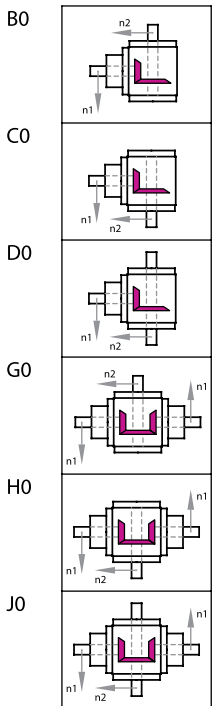

Achtung: Standardbefestigungsgewinde im Gehäuse nur an den Seiten 1, 2 & 4.
 Alternativ auch an den Seiten 3, 5 & 6 im Rastermaß 54x54 möglich.
Note: Standard fastening thread in the housing only on sides 1, 2 & 4.
 Alternatively, also possible in the grid dimension of 54x54 on sides 3, 5 & 6.

Übersetzung / Transmission Ratios

Übers./Ratio	d	da	l	v	x	y	z	t	DR	e	o	p	Übers./Ratio	d	da	l	v	x	y	z	t	DR	e	o	p
i = 1:1 - 2:1	12	17	26	0,5	4	3	20	1,5	M4	100	72	44	i = 3:1	12	17	26	0,5	4	3	20	1,5	M4	100	72	44

IV Leistungen, Drehmomente / Power Ratings, Torque Ratings

[n = min-1, P = kW, T = Nm]

i =	1:1	P1N	1,5:1	P1N	2:1	P1N	3:1	P1N
n1	n2	T2N	n2	T2N	n2	T2N	n2	T2N
3000	3000	3,31	2000	2,20	1500	1,65	1000	1,10
		10,00		10,00		10,00		10,00
2400	2400	2,65	1600	1,76	1200	1,32	800	0,88
		10,00		10,00		10,00		10,00
1500	1500	1,82	1000	1,21	750	0,91	500	0,61
		11,00		11,00		11,00		11,00
1000	1000	1,32	667	0,88	500	0,66	333	0,44
		12,00		12,00		12,00		12,00
750	750	1,07	500	0,72	375	0,54	250	0,33
		13,00		13,00		13,00		13,00
500	500	0,83	333	0,55	250	0,41	167	0,24
		15,00		15,00		15,00		13,00
250	250	0,47	167	0,31	125	0,23	83	0,12
		17,00		17,00		17,00		13,00
50	50	0,10	33	0,07	25	0,05	17	0,03
		18,00		18,00		18,00		14,00
P1Nt		1,60		1,60		1,60		1,60
T2max		25,00		25,00		25,00		23,00

Radialkräfte / Radial Forces (N)

T2 Nm	n1 (1/min)						T2 Nm	n2 (1/min)					
	3000	1000	500	250	100	50		3000	1000	500	250	100	50
< 12	180	250	300	350	450	550	< 12	300	400	500	650	750	900
> 12	150	210	250	290	380	460	> 12	250	330	420	540	630	750

Weitere Erläuterungen und verstärkte Lagerungen siehe Allgemeines / For more information and reinforced bearings, refer to general information.
 Axialkräfte FA = 50% der Radialkräfte - siehe Allgemeines / Axial forces FA = 50% of radial forces - refer to general information.

Massenträgheitsmomente / Moments of Inertia J (kgcm²)

reduziert auf die Antriebswelle (n1) / reduced to the input shaft (n1)

Bauart Model	Übersetzung / Transmission Ratios			
	1:1	1,5:1	2:1	3:1
A0	0,3888	0,2406	0,1839	0,1036
F0	0,5832	0,3270	0,2325	0,1252
M0	0,5832	0,3948	0,3192	0,1856
B0, C0	0,4231	0,3111	0,2330	0,1001
D0	0,4330	0,3155	0,2355	0,1012
G0, H0	0,6175	0,4653	0,3683	0,1821
J0	0,6274	0,4697	0,3708	0,1832

Getriebegewichte

Gearbox Weights (kg)

Bauart Model	ca. Gewicht app. Weight
A0	2,3
F0	2,7
M0	2,7
B0, C0	2,2
D0	2,3
G0, H0	2,6
J0	2,7

V Befestigungsseite / Mounting Side

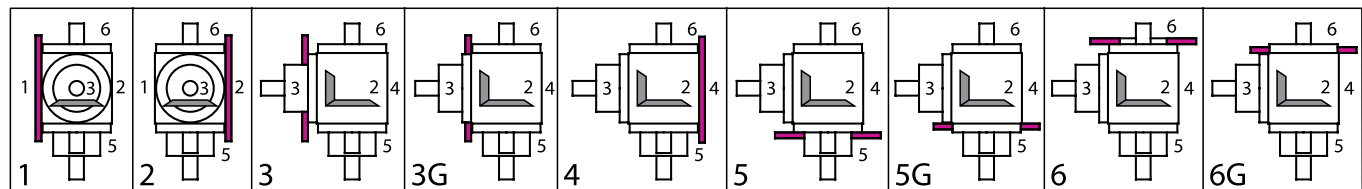

VI Einbautagen (unten liegende Getriebeseite) / Mounting Configuration (downward-facing side)

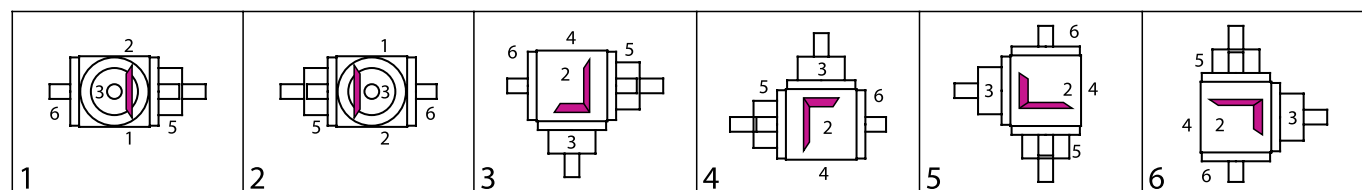

Bestellbeispiel / Example of Order

I Typ	Größe	IV Übersetzung	III Bauart	V Befestigungs-	VI Einbautage	IV Drehzahl	Ausführung
Type	Size	Ratio	Model	Mounting Side	Mounting Config.	Speed	Design
V	065	1:1	A0	1	1	500 / n2max	0000=Standard

Kegelradgetriebe Typ V
Bevel Gearboxes Type V

Typ V 065

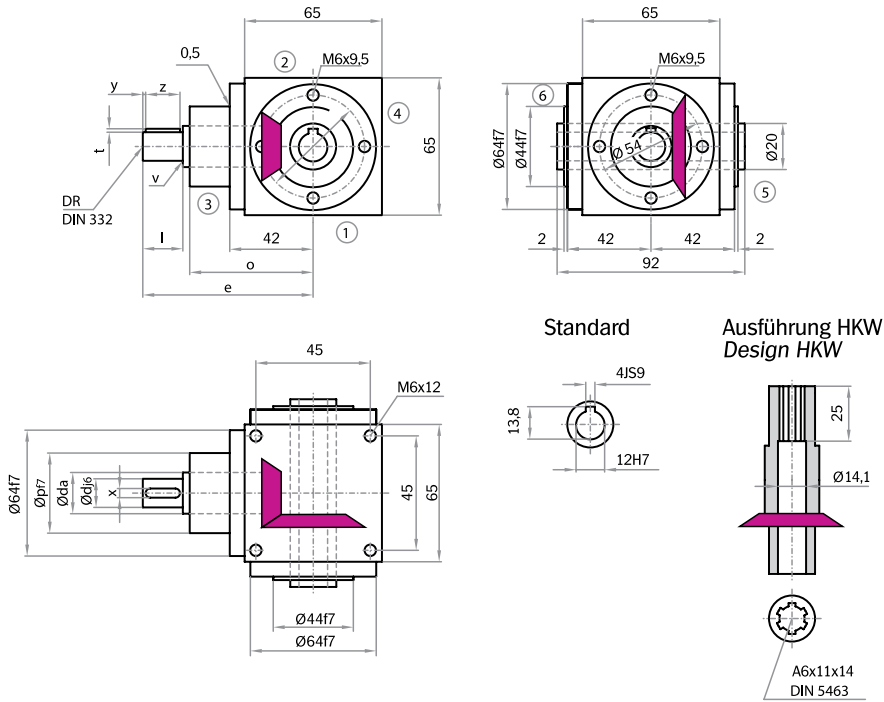

Bauart / Model

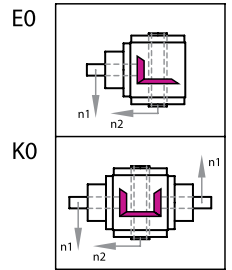

Achtung: Standardbefestigungsgewinde im Gehäuse nur an den Seiten 1, 2 & 4.
Alternativ auch an den Seiten 3, 5 & 6 im Rastermaß 54x54 möglich.
Note: Standard fastening thread in the housing only on sides 1, 2 & 4.
Alternatively, also possible in the grid dimension of 54x54 on sides 3, 5 & 6.

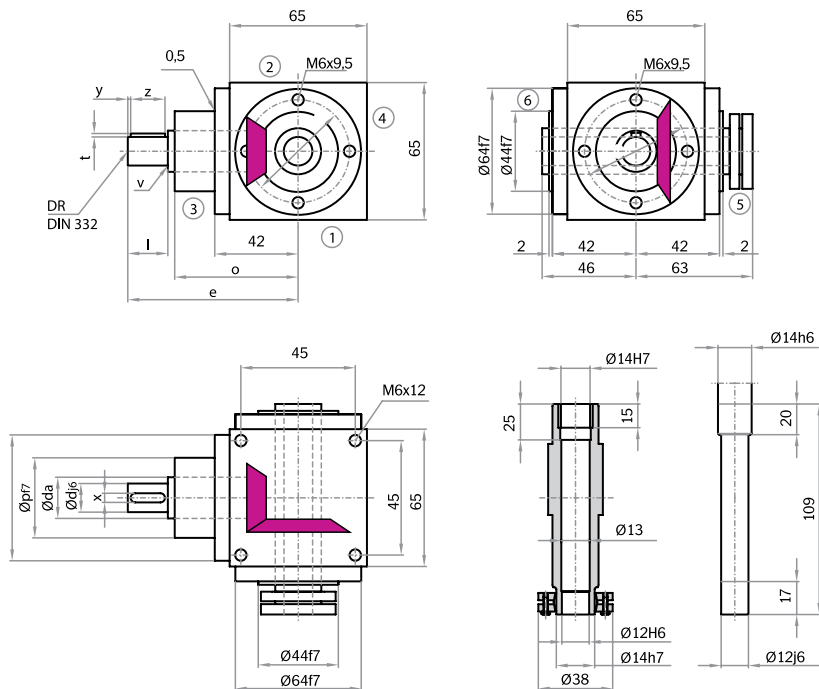

Bauart / Model

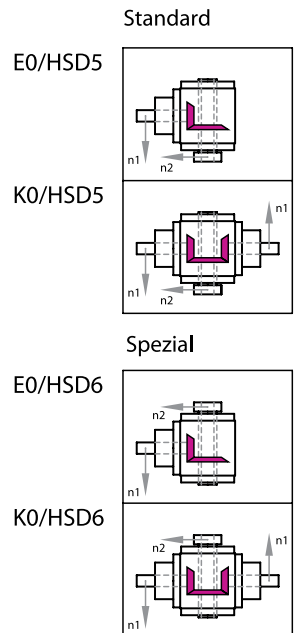

Achtung: Standardbefestigungsgewinde im Gehäuse nur an den Seiten 1, 2 & 4.
Alternativ auch an den Seiten 3, 5 & 6 im Rastermaß 54x54 möglich.
Note: Standard fastening thread in the housing only on sides 1, 2 & 4.
Alternatively, also possible in the grid dimension of 54x54 on sides 3, 5 & 6.

Übersetzung / Transmission Ratios

Übers./Ratio	d	da	l	v	x	y	z	t	DR	e	o	p	Übers./Ratio	d	da	l	v	x	y	z	t	DR	e	o	p
i = 1:1 - 2:1	12	17	26	0,5	4	3	20	1,5	M4	100	72	44	i = 3:1	12	17	26	0,5	4	3	20	1,5	M4	72	44	

IV Leistungen, Drehmomente / Power Ratings, Torque Ratings

[n = min-1, P = kW, T = Nm]

i =	1:1	P1N	1,5:1	P1N	2:1	P1N	3:1	P1N
n1	n2	T2N	n2	T2N	n2	T2N	n2	T2N
3000	3000	3,31	2000	2,20	1500	1,65	1000	1,10
		10,00		10,00		10,00		10,00
2400	2400	2,65	1600	1,76	1200	1,32	800	0,88
		10,00		10,00		10,00		10,00
1500	1500	1,82	1000	1,21	750	0,91	500	0,61
		11,00		11,00		11,00		11,00
1000	1000	1,32	667	0,88	500	0,66	333	0,44
		12,00		12,00		12,00		12,00
750	750	1,07	500	0,72	375	0,54	250	0,33
		13,00		13,00		13,00		12,00
500	500	0,83	333	0,55	250	0,41	167	0,24
		15,00		15,00		15,00		13,00
250	250	0,47	167	0,31	125	0,23	83	0,12
		17,00		17,00		17,00		13,00
50	50	0,10	33	0,07	25	0,05	17	0,03
		18,00		18,00		18,00		14,00
P1Nt		1,60		1,60		1,60		1,60
T2max		25,00		25,00		25,00		23,00

Radialkräfte / Radial Forces (N)

T2 Nm	n1 (1/min)						n2 (1/min)					
	3000	1000	500	250	100	50	3000	1000	500	250	100	50
< 12	180	250	300	350	450	550	300	400	500	650	750	900
> 12	150	210	250	290	380	460	250	330	420	540	630	750

Weitere Erläuterungen und verstärkte Lagerungen siehe Allgemeines / For more information and reinforced bearings, refer to general Information.
 Axialkräfte FA = 50% der Radialkräfte - siehe Allgemeines / Axial forces FA = 50% of radial forces - refer to general information.

Massenträgheitsmomente / Moments of Inertia J (kgcm²)

reduziert auf die Antriebswelle (n1) / reduced to the input shaft (n1)

Bauart Model	Übersetzung / Transmission Ratios			
	1:1	1,5:1	2:1	3:1
E0	0,4754	0,3634	0,2853	0,1524
K0	0,6698	0,5176	0,4206	0,2344
E0/HSD	0,6012	0,4892	0,4111	0,2782
K0/HSD	0,7956	0,6434	0,5464	0,3602

Getriebegewichte

Gearbox Weights (kg)

Bauart Model	ca. Gewicht app. Weight
E0	2,1
K0	2,5
E0/HSD	2,1
K0/HSD	2,5

V Befestigungsseite / Mounting Side

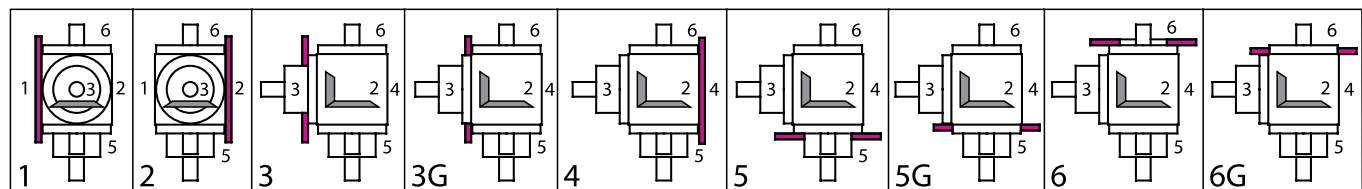

VI Einbautagen (unten liegende Getriebeseite) / Mounting Configuration (downward-facing side)

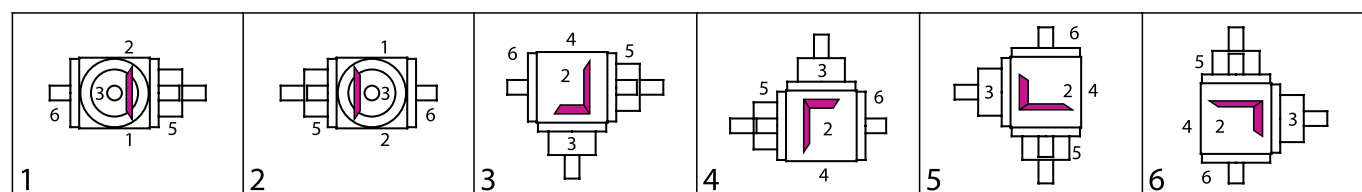

Bestellbeispiel / Example of Order

I Typ	Größe	IV Übersetzung	III Bauart	V Befestigungs.	VI Einbautage	IV Drehzahl	Ausführung
Type	Size	Ratio	Model	Mounting Side	Mounting Config.	Speed	Design
V	065	1:1	E0	1	1	500 / n2max	0000=Standard

Kegelradgetriebe Typ V
Bevel Gearboxes Type V

Typ V 090

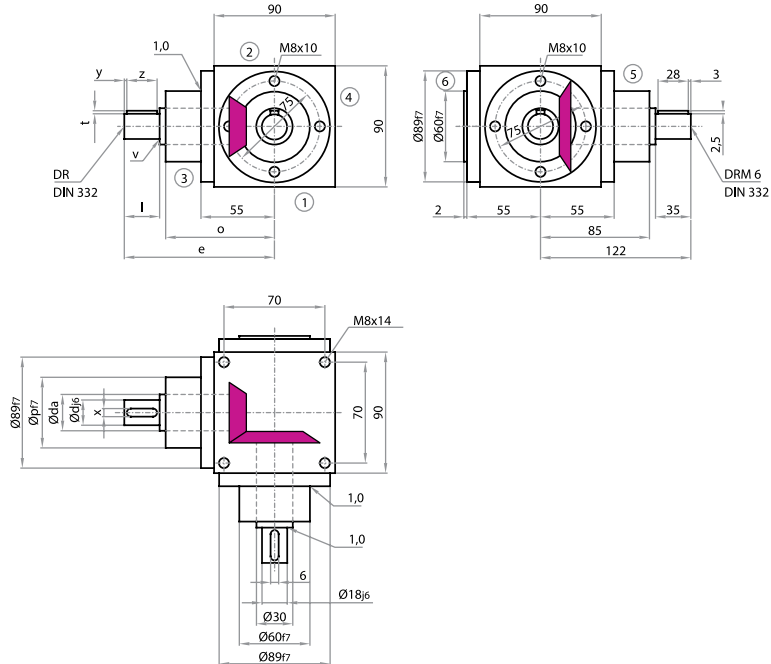

Bauart / Model

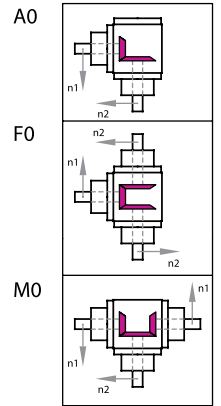

Achtung: Standardbefestigungsgewinde im Gehäuse nur an den Seiten 1, 2 & 4.
 Alternativ auch an den Seiten 3, 5 & 6 im Rastermaß 75x75 möglich.
Note: Standard fastening thread in the housing only on sides 1, 2 & 4.
 Alternatively, also possible in the grid dimension of 75x75 on sides 3, 5 & 6.

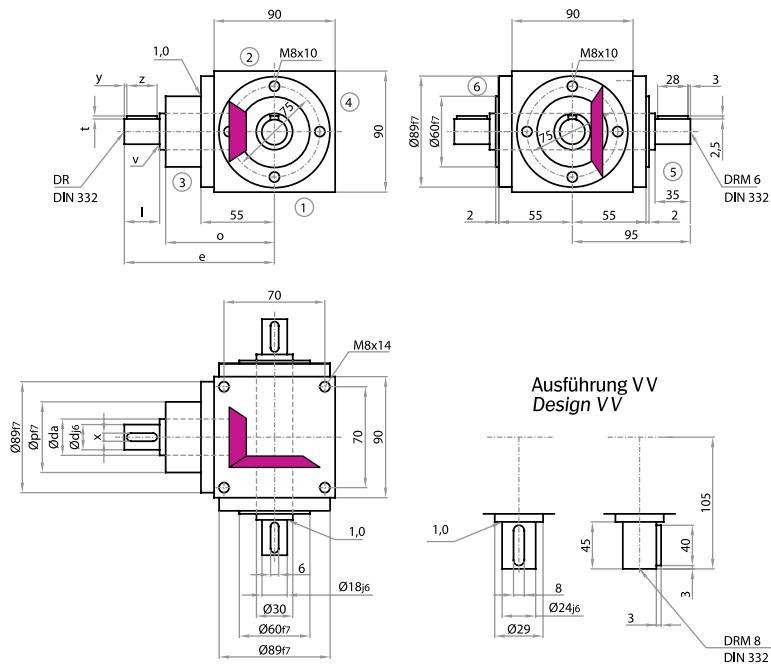

Bauart / Model

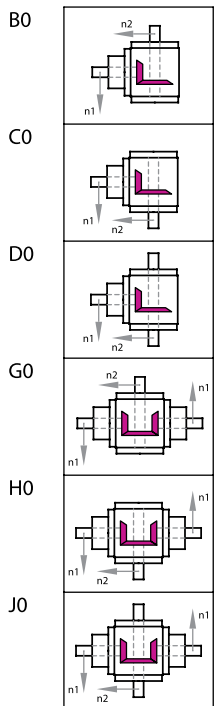

Achtung: Standardbefestigungsgewinde im Gehäuse nur an den Seiten 1, 2 & 4.
 Alternativ auch an den Seiten 3, 5 & 6 im Rastermaß 75x75 möglich.
Note: Standard fastening thread in the housing only on sides 1, 2 & 4.
 Alternatively, also possible in the grid dimension of 75x75 on sides 3, 5 & 6.

Übersetzung / Transmission Ratios

Übers./Ratio	d	da	l	v	x	y	z	t	DR	e	o	p	Übers./Ratio	d	da	l	v	x	y	z	t	DR	e	o	p
i = 1:1 - 2:1	18	25	35	1	6	3	28	2,5	M6	122	85	60	i = 3:1	12	20	35	0,5	4	3	28	1,5	M4	122	85	60
i = 4:1	12	20	35	0,5	4	3	28	1,5	M4	132	95	60	i = 5:1 - 6:1	12	20	35	0,5	4	3	28	1,5	M4	132	95	60

IV Leistungen, Drehmomente / Power Ratings, Torque Ratings

[n = min-1, P = kW, T = Nm]

i =	1:1	P1N	1,5:1	P1N	2:1	P1N	3:1	P1N	4:1	P1N	5:1	P1N	6:1	P1N
n1	n2	T2N	n2	T2N	n2	T2N	n2	T2N	n2	T2N	n2	T2N	n2	T2N
3000	3000	8,93	2000	5,51	1500	3,80	1000	2,54	750	1,90	600	1,52	500	1,25
		27,00		25,00		23,00		23,00		23,00		23,00		23,00
2400	2400	7,41	1600	4,59	1200	3,17	800	2,12	600	1,65	480	1,32	400	1,09
		28,00		26,00		24,00		24,00		25,00		25,00		25,00
1500	1500	5,29	1000	3,20	750	2,23	500	1,49	375	1,12	300	0,89	250	0,74
		32,00		29,00		27,00		27,00		27,00		27,00		27,00
1000	1000	3,75	667	2,35	500	1,71	333	1,14	250	0,85	200	0,68	167	0,53
		34,00		32,00		31,00		31,00		31,00		31,00		29,00
750	750	3,06	500	1,93	375	1,32	250	0,88	187,5	0,66	150	0,53	125	0,40
		37,00		35,00		32,00		32,00		32,00		32,00		29,00
500	500	2,20	333	1,36	250	0,94	167	0,63	125	0,47	100	0,37	83	0,27
		40,00		37,00		34,00		34,00		34,00		34,00		29,00
250	250	1,21	167	0,74	125	0,50	83	0,33	62,5	0,25	50	0,20	42	0,14
		44,00		40,00		36,00		36,00		36,00		36,00		30,00
50	50	0,28	33	0,16	25	0,10	17	0,07	12,5	0,05	10	0,04	8,3	0,03
		50,00		45,00		37,00		37,00		37,00		37,00		33,00
P1Nt		3,80		3,80		3,80		3,80		3,80		3,80		3,80
T2max		105,00		45,00		80,00		70,00		70,00		60,00		50,00

Radialkräfte / Radial Forces (N)

FA	T2 Nm	n1 (1/min)						FA	T2 Nm	n2 (1/min)					
		3000	1000	500	250	100	50			3000	1000	500	250	100	50
< 30		300	400	470	580	700	800			500	660	800	950	1250	1500
> 30		250	330	390	490	590	670			420	550	670	790	1040	1250

Weitere Erläuterungen und verstärkte Lagerungen siehe Allgemeines / For more information and reinforced bearings, refer to general Information.
 Axialkräfte FA = 50% der Radialkräfte - siehe Allgemeines / Axial forces FA = 50% of radial forces - refer to general information.

Massenträgheitsmomente / Moments of Inertia J (kgcm²)

reduziert auf die Antriebswelle (n1) / reduced to the input shaft (n1)

Bauart Model	Übersetzung / Transmission Ratios						
	1:1	1,5:1	2:1	3:1	4:1	5:1	6:1
A0	2,5590	1,4822	1,1437	0,8884	0,3631	0,3248	0,3062
F0	3,8385	2,0508	1,4636	1,0305	0,4430	0,3760	0,3418
M0	3,8385	2,3957	1,9675	1,6346	0,6462	0,5984	0,5769
B0, C0	3,3543	2,1833	1,3652	1,0465	0,4607	0,3933	0,3502
D0	3,3827	2,1959	1,3723	1,0496	0,4625	0,3945	0,3510
G0, H0	4,6338	3,0968	2,1890	1,7927	0,7438	0,6669	0,6209
J0	4,6622	3,1094	2,1961	1,7958	0,7456	0,6681	0,6217

Getriebegewichte

Gearbox Weights (kg)

Bauart Model	ca. Gewicht app. Weight
A0	5,1
F0	6,3
M0	6,3
B0, C0	5,4
D0	5,5
G0, H0	6,9
J0	7

V Befestigungsseite / Mounting Side

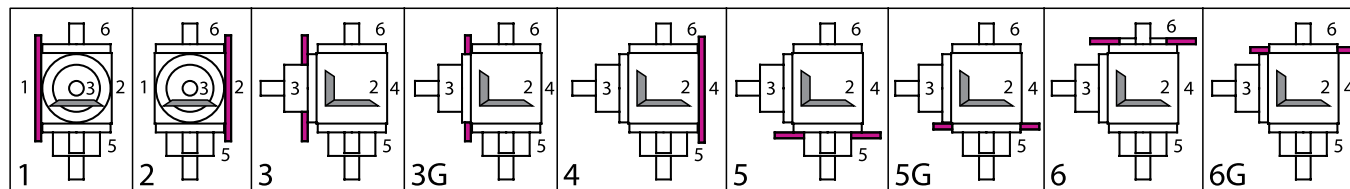

VI Einbautagen (unten liegende Getriebeseite) / Mounting Configuration (downward-facing side)

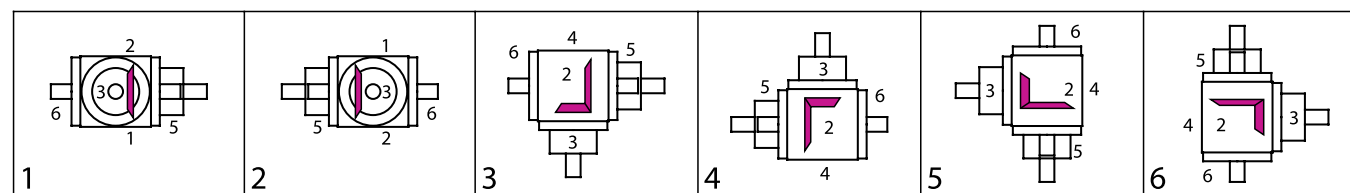

Bestellbeispiel / Example of Order

I Typ Type	Größe Size	IV Übersetzung Ratio	III Bauart Model	V Befestigungs- Mounting Side	VI Einbautage Mounting Config.	IV Drehzahl Speed	Ausführung Design
V	090	1:1	A0	1	1	500 / n2max	0000=Standard

Kegelradgetriebe Typ V
Bevel Gearboxes Type V

Typ V 090

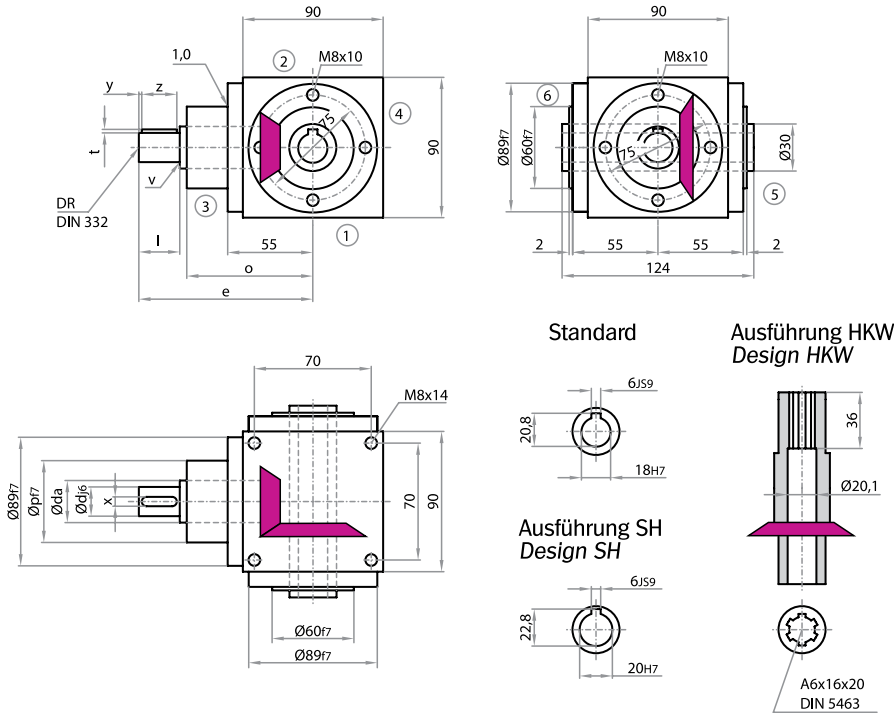

Bauart / Model

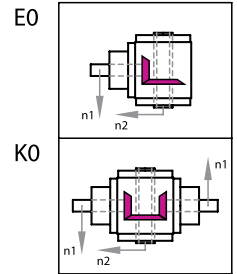

Achtung: Standardbefestigungsgewinde im Gehäuse nur an den Seiten 1, 2 & 4.
 Alternativ auch an den Seiten 3, 5 & 6 im Rastermaß 75x75 möglich.
Note: Standard fastening thread in the housing only on sides 1, 2 & 4.
 Alternatively, also possible in the grid dimension of 75x75 on sides 3, 5 & 6.

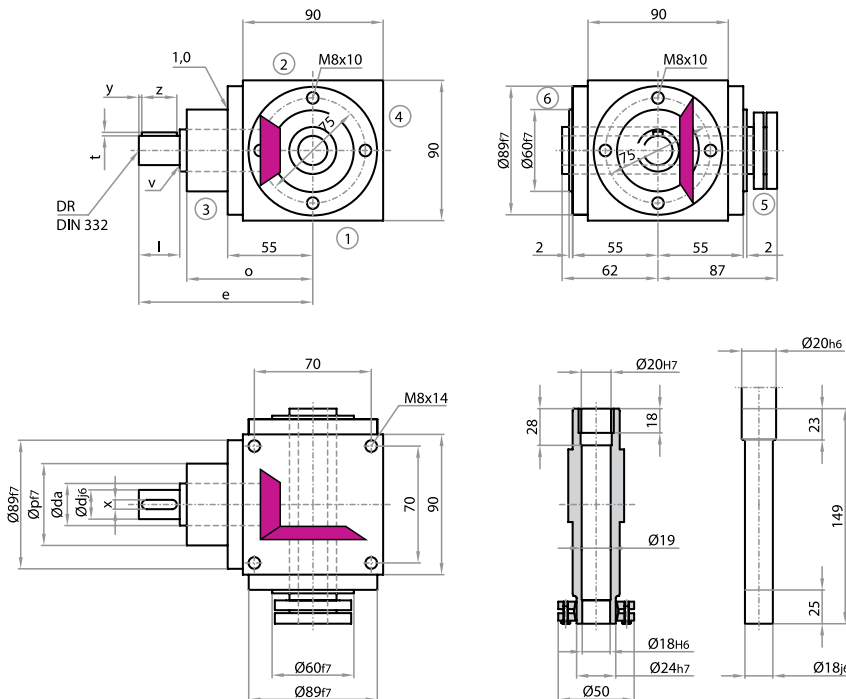

Bauart / Model

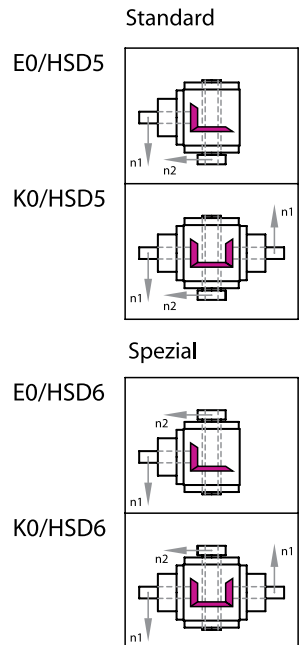

Achtung: Standardbefestigungsgewinde im Gehäuse nur an den Seiten 1, 2 & 4.
 Alternativ auch an den Seiten 3, 5 & 6 im Rastermaß 75x75 möglich.
Note: Standard fastening thread in the housing only on sides 1, 2 & 4.
 Alternatively, also possible in the grid dimension of 75x75 on sides 3, 5 & 6.

Übersetzung / Transmission Ratios

Übers./Ratio	d	da	l	v	x	y	z	t	DR	e	o	p	Übers./Ratio	d	da	l	v	x	y	z	t	DR	e	o	p
i = 1:1 - 2:1	18	25	35	1	6	3	28	2,5	M6	122	85	60	i = 3:1	12	20	35	0,5	4	3	28	1,5	M4	122	85	60
i = 4:1	12	20	35	0,5	4	3	28	1,5	M4	132	95	60	i = 5:1 - 6:1	12	20	35	0,5	4	3	28	1,5	M4	132	95	60

IV Leistungen, Drehmomente / Power Ratings, Torque Ratings

[n = min-1, P = kW, T = Nm]

i = n1	1:1 n2	P1N T2N	1,5:1 n2	P1N T2N	2:1 n2	P1N T2N	3:1 n2	P1N T2N	4:1 n2	P1N T2N	5:1 n2	P1N T2N	6:1 n2	P1N T2N
3000	3000	8,93 27,00	2000	5,51 25,00	1500	3,80 23,00	1000	2,54 23,00	750	1,90 23,00	600	1,52 23,00	500	1,25 23,00
2400	2400	7,41 28,00	1600	4,59 26,00	1200	3,17 24,00	800	2,12 24,00	600	1,65 25,00	480	1,32 25,00	400	1,09 25,00
1500	1500	5,29 32,00	1000	3,20 29,00	750	2,23 27,00	500	1,49 27,00	375	1,12 27,00	300	0,89 27,00	250	0,74 27,00
1000	1000	3,75 34,00	667	2,35 32,00	500	1,71 31,00	333	1,14 31,00	250	0,85 31,00	200	0,68 31,00	167	0,53 29,00
750	750	3,06 37,00	500	1,93 35,00	375	1,32 32,00	250	0,88 32,00	187,5	0,66 32,00	150	0,53 32,00	125	0,40 29,00
500	500	2,20 40,00	333	1,36 37,00	250	0,94 34,00	167	0,63 34,00	125	0,47 34,00	100	0,37 34,00	83	0,27 29,00
250	250	1,21 44,00	167	0,74 40,00	125	0,50 36,00	83	0,33 36,00	62,5	0,25 36,00	50	0,20 36,00	42	0,14 30,00
50	50	0,28 50,00	33	0,16 45,00	25	0,10 37,00	17	0,07 37,00	12,5	0,05 37,00	10	0,04 37,00	8,3	0,03 33,00
P1Nt		3,80		3,80		3,80		3,80		3,80		3,80		3,80
T2max		105,00		45,00		80,00		70,00		70,00		60,00		50,00

Radialkräfte / Radial Forces (N)

FA	T2 Nm	n1 (1/min)						FA	T2	n2 (1/min)					
		3000	1000	500	250	100	50			3000	1000	500	250	100	50
<	30	300	400	470	580	700	800			500	660	800	950	1250	1500
>	30	250	330	390	490	590	670			420	550	670	790	1040	1250

Weitere Erläuterungen und verstärkte Lagerungen siehe Allgemeines / For more information and reinforced bearings, refer to general Information.
 Axialkräfte FA = 50% der Radialkräfte - siehe Allgemeines / Axial forces FA = 50% of radial forces - refer to general information.

Massenträgheitsmomente / Moments of Inertia J (kgcm²)

reduziert auf die Antriebswelle (n1) / reduced to the input shaft (n1)

Bauart Model	Übersetzung / Transmission Ratios						
	1:1	1,5:1	2:1	3:1	4:1	5:1	6:1
E0	3,2507	2,1372	1,3393	1,0350	0,4542	0,3892	0,3473
K0	4,5302	3,0507	2,1631	1,7812	0,7373	0,6628	0,6180
E0/HSD	3,9213	2,4353	1,5069	1,1095	0,4961	0,4160	0,3660
K0/HSD	5,2008	3,3488	2,3307	1,8557	0,7792	0,6896	0,6367

Getriebegewichte Gearbox Weights (kg)

Bauart Model	ca. Gewicht app. Weight
E0	5
K0	6.5
E0/HSD	5.2
K0/HSD	6.7

V Befestigungsseite / Mounting Side

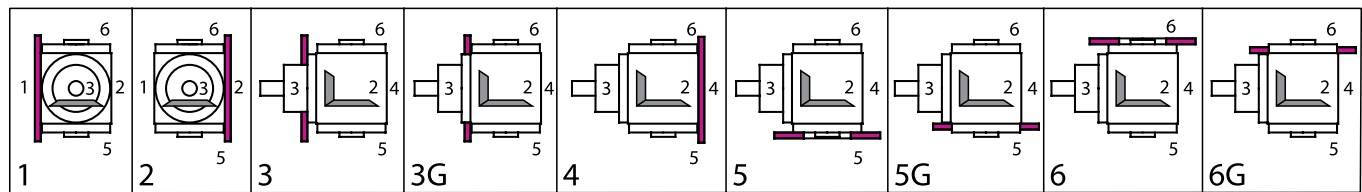

VI Einbautagen (unten liegende Getriebeseite) / Mounting Configuration (downward-facing side)

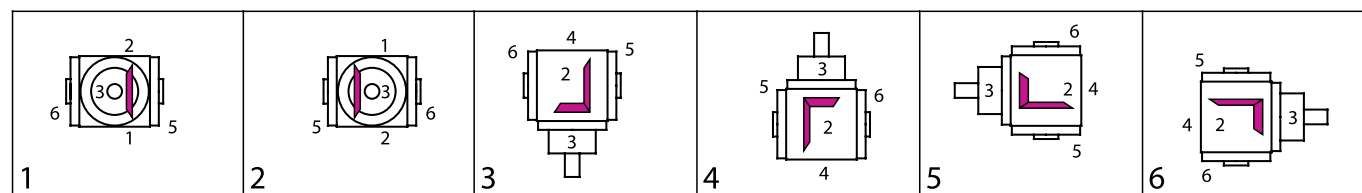

Bestellbeispiel / Example of Order

I Typ Type	Größe Size	IV Übersetzung Ratio	III Bauart Model	V Befestigungs- Mounting Side	VI Einbautage Mounting Config.	IV Drehzahl Speed	n2max n2max	Ausführung Design
V	090	1:1	E0	1	.	1	500	0000=Standard

Kegelradgetriebe Typ V
Bevel Gearboxes Type V

Typ V 120

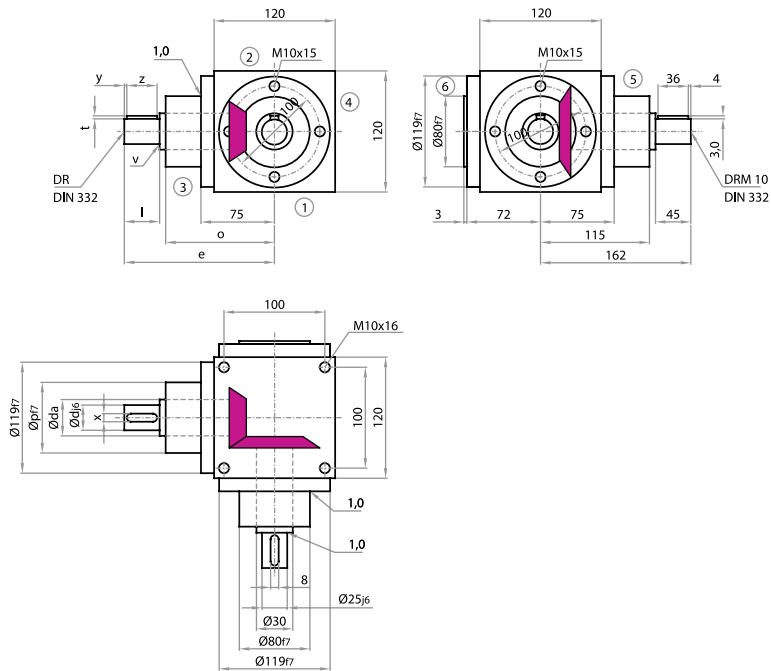

Bauart / Model

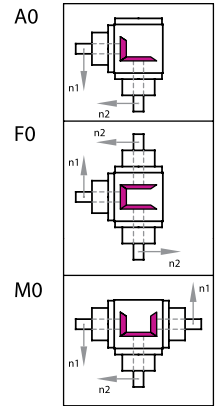

Achtung: Standardbefestigungsgewinde im Gehäuse nur an den Seiten 1, 2 & 4. Alternativ auch an den Seiten 3, 5 & 6 möglich.
Note: Standard fastening thread in the housing only on sides 1, 2 & 4. Alternatively, also possible on sides 3, 5 & 6.

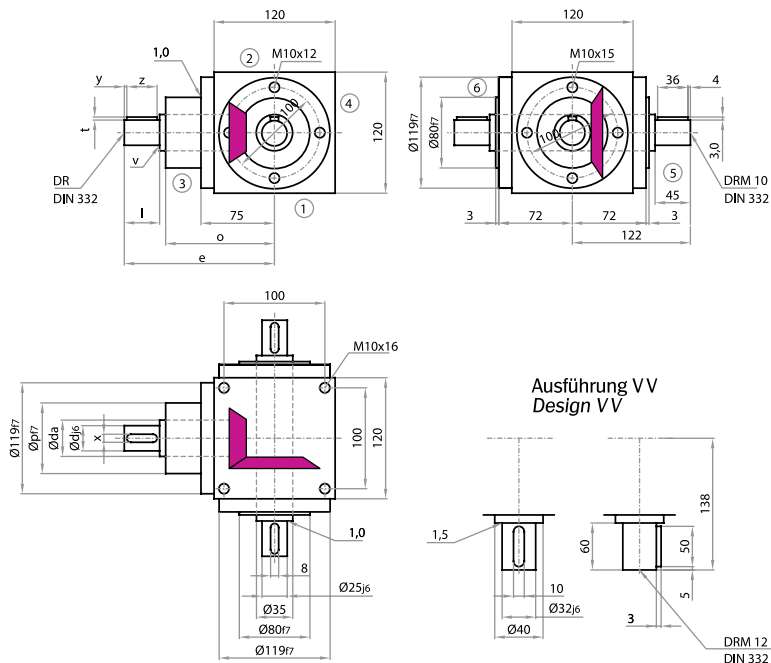

Bauart / Model

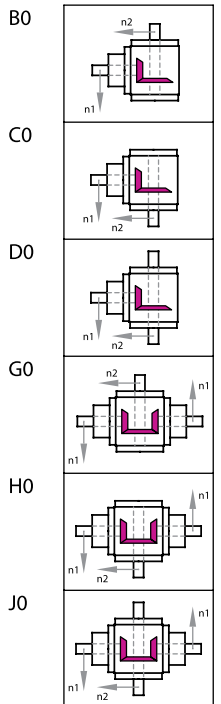

Achtung: Standardbefestigungsgewinde im Gehäuse nur an den Seiten 1, 2 & 4. Alternativ auch an den Seiten 3, 5 & 6 möglich.
Note: Standard fastening thread in the housing only on sides 1, 2 & 4. Alternatively, also possible on sides 3, 5 & 6.

Übersetzung / Transmission Ratios

Übers./Ratio	d	da	l	v	x	y	z	t	DR	e	o	p
i = 1:1 - 2:1	25	30	45	1	8	4	36	3	M10	162	115	80
i = 3:1	20	25	45	1	6	4	36	2,5	M6	162		80
Übers./Ratio	d	da	l	v	x	y	z	t	DR	e	o	p
i = 4:1	20	25	45	1	6	4	36	2,5	M6	172	125	80
Übers./Ratio	d	da	l	v	x	y	z	t	DR	e	o	p
i = 5:1 - 6:1	15	20	35	0,5	5	4	28	2	M5	162		70

IV Leistungen, Drehmomente / Power Ratings, Torque Ratings

[n = min-1, P = kW, T = Nm]

i =	1:1	P1N	1,5:1	P1N	2:1	P1N	3:1	P1N	4:1	P1N	5:1	P1N	6:1	P1N
n1	n2	T2N	n2	T2N	n2	T2N	n2	T2N	n2	T2N	n2	T2N	n2	T2N
3000	3000	21,82 66,00	2000	13,45 61,00	1500	9,26 56,00	1000	6,39 58,00	750	4,96 60,00	600	3,97 60,00	500	2,95 54,00
2400	2400	18,52 70,00	1600	11,46 65,00	1200	8,07 61,00	800	5,56 63,00	600	4,43 67,00	480	3,44 65,00	400	2,53 57,00
1500	1500	13,56 82,00	1000	8,60 78,00	750	6,03 73,00	500	4,08 74,00	375	3,06 74,00	300	2,38 72,00	250	1,75 64,00
1000	1000	10,14 92,00	667	6,32 86,00	500	4,46 81,00	333	3,01 82,00	250	2,18 79,00	200	1,76 80,00	167	1,22 66,00
750	750	8,51 103,00	500	5,18 94,00	375	3,55 86,00	250	2,40 87,00	187,5	1,69 82,00	150	1,42 86,00	125	0,94 68,00
500	500	6,34 115,00	333	3,85 100,00	250	2,54 92,00	167	1,66 90,00	125	1,16 84,00	100	0,98 89,00	83	0,63 69,00
250	250	3,39 123,00	167	1,99 100,00	125	1,35 98,00	83	0,87 95,00	62,5	0,60 87,00	50	0,51 92,00	42	0,33 71,00
50	50	0,72 130,00	33	0,41 100,00	25	0,29	17	0,21 110,00	12,5	0,12 90,00	10	0,10 95,00	8,3	0,06 66,00
P1Nt		6,20		6,20		6,20		6,20		6,20		6,20		6,20
T2max		220,00												

Radialkräfte / Radial Forces (N)

T2 Nm	n1 (1/min)						n2 (1/min)					
	3000	1000	500	250	100	50	3000	1000	500	250	100	50
< 80	470	620	720	900	1150	1400	750	1000	1250	1500	1900	2200
> 80	390	520	600	750	960	1170	630	830	1040	1250	1580	1830

Weitere Erläuterungen und verstärkte Lagerungen siehe Allgemeines / For more information and reinforced bearings, refer to general information.
 Axialkräfte FA = 50% der Radialkräfte - siehe Allgemeines / Axial forces FA = 50% of radial forces - refer to general information.

Massenträgheitsmomente / Moments of Inertia J (kgcm²)

reduziert auf die Antriebswelle (n1) / reduced to the input shaft (n1)

Bauart Model	Übersetzung / Transmission Ratios						
	1:1	1,5:1	2:1	3:1	4:1	5:1	6:1
A0	10,4976	4,8409	3,6465	2,3159	1,2164	0,7516	0,6766
F0	15,7464	7,1737	4,9587	2,8991	1,5444	0,9615	0,8224
M0	15,7464	7,3490	5,9808	4,0486	2,1047	1,2932	1,2074
B0, C0	15,3022	7,4441	4,9747	3,0123	1,6729	1,0593	0,8982
D0	15,5996	7,5762	5,0490	3,0453	1,6915	1,0712	0,9065
G0, H0	20,5510	9,9522	7,3090	4,7450	2,5612	1,6009	1,4290
J0	20,8484	10,0843	7,3833	4,7780	2,5798	1,6128	1,4373

Getriebegewichte

Gearbox Weights (kg)

Bauart Model	ca. Gewicht app. Weight
A0	12,6
F0	15
M0	15
B0, C0	12,3
D0	12,5
G0, H0	14,7
J0	14,9

V Befestigungsseite / Mounting Side

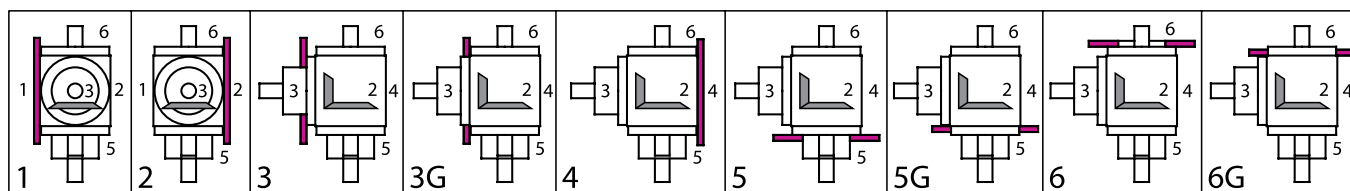

VI Einbautagen (unten liegende Getriebeseite) / Mounting Configuration (downward-facing side)

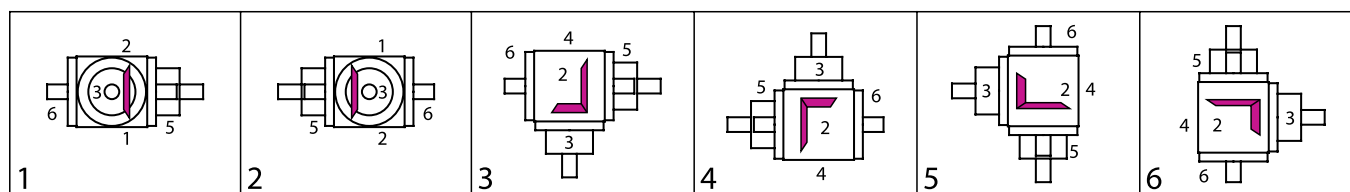

Bestellbeispiel / Example of Order

I Typ Type	Größe Size	IV Übersetzung Ratio	III Bauart Model	V Befestigungs- Mounting Side	VI Einbautage Mounting Config.	IV Drehzahl Speed	n2max n2max	Ausführung Design
V	120	1:1	A0	1	.	1	500	0000=Standard

Kegelradgetriebe Typ V
Bevel Gearboxes Type V

Typ V 120

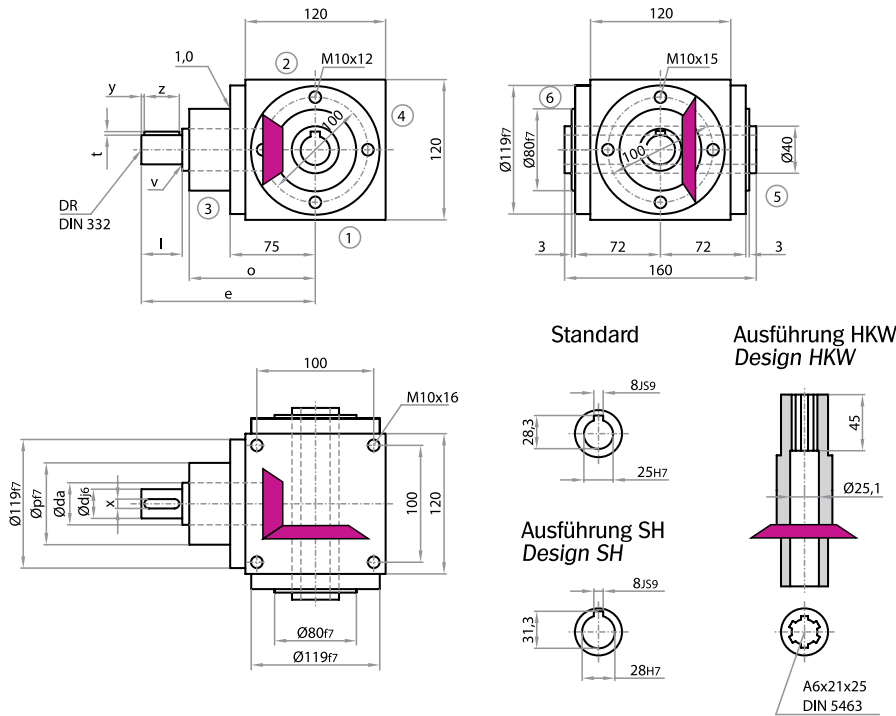

Bauart / Model

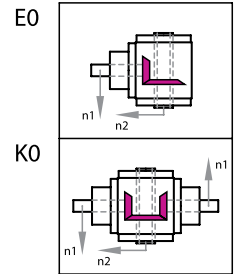

Achtung: Standardbefestigungsgewinde im Gehäuse nur an den Seiten 1, 2 & 4. Alternativ auch an den Seiten 3, 5 & 6 möglich.
Note: Standard fastening thread in the housing only on sides 1, 2 & 4. Alternatively, also possible on sides 3, 5 & 6.

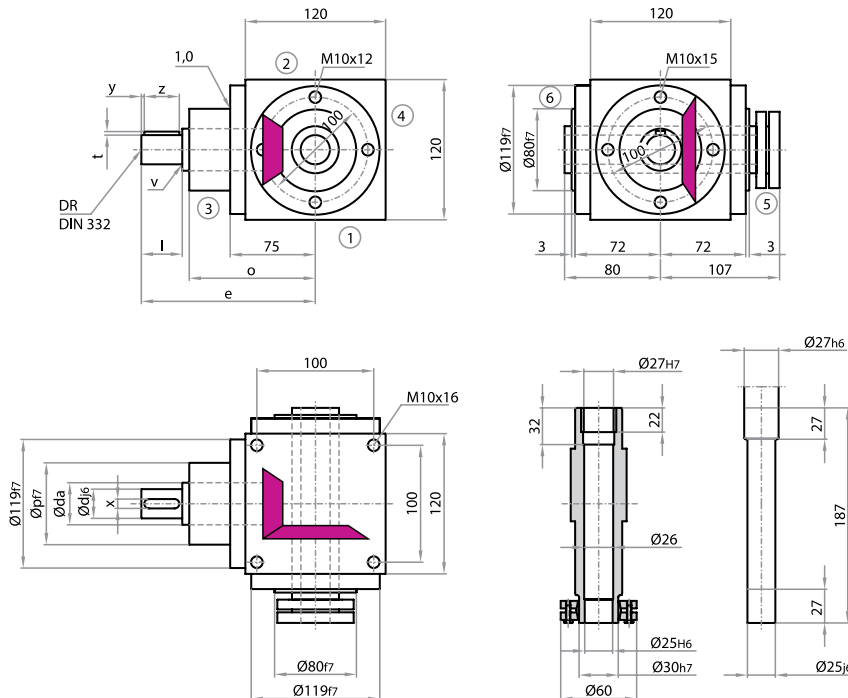

Bauart / Model

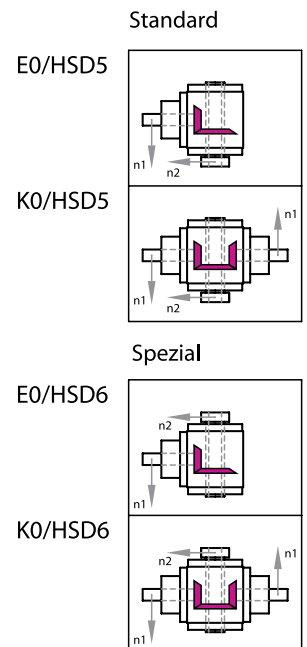

Achtung: Standardbefestigungsgewinde im Gehäuse nur an den Seiten 1, 2 & 4. Alternativ auch an den Seiten 3, 5 & 6 möglich.
Note: Standard fastening thread in the housing only on sides 1, 2 & 4. Alternatively, also possible on sides 3, 5 & 6.

Übersetzung / Transmission Ratios

Übers./Ratio	d	da	l	v	x	y	z	t	DR	e	o	p	Übers./Ratio	d	da	l	v	x	y	z	t	DR	e	o	p
i = 1:1 - 2:1	25	30	45	1	8	4	36	3	M10	162	115	80	i = 3:1	20	25	45	1	6	4	36	2,5	M6	162	115	80
i = 4:1	20	25	45	1	6	4	36	2,5	M6	172	125	80	i = 5:1 - 6:1	15	20	35	0,5	5	4	28	2	M5	162	125	70

IV Leistungen, Drehmomente / Power Ratings, Torque Ratings

[n = min-1, P = kW, T = Nm]

i = n1	1:1 n2	P1N T2N	1,5:1 n2	P1N T2N	2:1 n2	P1N T2N	3:1 n2	P1N T2N	4:1 n2	P1N T2N	5:1 n2	P1N T2N	6:1 n2	P1N T2N
3000	3000	21,82 66,00	2000	13,45 61,00	1500	9,26 56,00	1000	6,39 58,00	750	4,96 60,00	600	3,97 60,00	500	2,95 54,00
2400	2400	18,52 70,00	1600	11,46 65,00	1200	8,07 61,00	800	5,56 63,00	600	4,43 67,00	480	3,44 65,00	400	2,53 57,00
1500	1500	13,56 82,00	1000	8,60 78,00	750	6,03 73,00	500	4,08 74,00	375	3,06 74,00	300	2,38 72,00	250	1,75 64,00
1000	1000	10,14 92,00	667	6,32 86,00	500	4,46 81,00	333	3,01 82,00	250	2,18 79,00	200	1,76 80,00	167	1,22 66,00
750	750	8,51 103,00	500	5,18 94,00	375	3,55 86,00	250	2,40 87,00	187,5	1,69 82,00	150	1,42 86,00	125	0,94 68,00
500	500	6,34 115,00	333	3,85 100,00	250	2,54 92,00	167	1,66 90,00	125	1,16 84,00	100	0,98 89,00	83	0,63 69,00
250	250	3,39 123,00	167	1,99 100,00	125	1,35 98,00	83	0,87 95,00	62,5	0,60 87,00	50	0,51 92,00	42	0,33 71,00
50	50	0,72 130,00	33	0,41 100,00	25	0,29 107,00	17	0,21 110,00	12,5	0,12 90,00	10	0,10 95,00	8,3	0,06 66,00
P1Nt		6,20		6,20		6,20		6,20		6,20		6,20		6,20
T2max		220,00		100,00		169,00		155,00		155,00		140,00		120,00

Radialkräfte / Radial Forces (N)

FA	T2 Nm	n1 (1/min)					n2 (1/min)						
		3000	1000	500	250	100	50	3000	1000	500	250	100	50
<	80	470	620	720	900	1150	1400	750	1000	1250	1500	1900	2200
>	80	390	520	600	750	960	1170	630	830	1040	1250	1580	1830

Weitere Erläuterungen und verstärkte Lagerungen siehe Allgemeines / For more information and reinforced bearings, refer to general Information.
 Axialkräfte FA = 50% der Radialkräfte - siehe Allgemeines / Axial forces FA = 50% of radial forces - refer to general information.

Massenträgheitsmomente / Moments of Inertia J (kgcm²)

reduziert auf die Antriebswelle (n1) / reduced to the input shaft (n1)

Bauart Model	Übersetzung / Transmission Ratios						
	1:1	1,5:1	2:1	3:1	4:1	5:1	6:1
E0	15,1939	7,3959	4,9476	3,0003	1,6661	1,0550	0,8952
K0	20,4427	9,9040	7,2819	4,7330	2,5544	1,5966	1,4260
E0/HSD	16,9812	8,1903	5,3944	3,1988	1,7778	1,1265	0,9449
K0/HSD	22,2300	10,6984	7,7287	4,9315	2,6661	1,6681	1,4757

Getriebegewichte Gearbox Weights (kg)

Bauart Model	ca. Gewicht app. Weight
E0	12
K0	14,4
E0/HSD	12,3
K0/HSD	14,7

V Befestigungsseite / Mounting Side

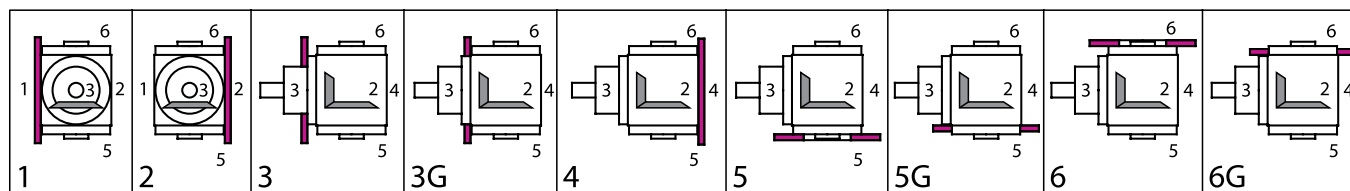

VI Einbautagen (unten liegende Getriebeseite) / Mounting Configuration (downward-facing side)

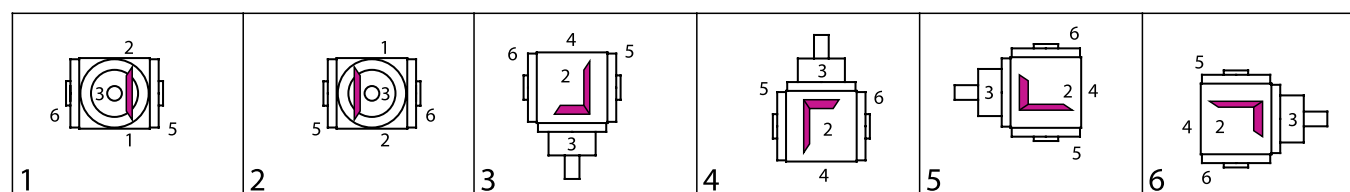

Bestellbeispiel / Example of Order

I Typ Type	Größe Size	IV Übersetzung Ratio	III Bauart Model	V Befestigungs- Mounting Side	VI Einbautage Mounting Config.	IV Drehzahl Speed	n2max n2max	Ausführung Design
V	120	1:1	E0	1	.	1	500	0000=Standard

Kegelradgetriebe Typ V
Bevel Gearboxes Type V

Typ V 140

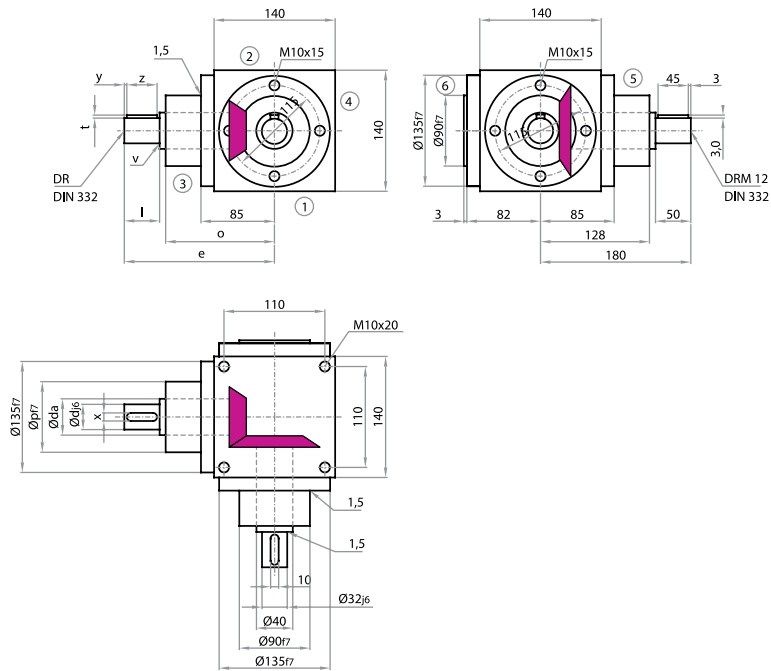

Bauart / Model

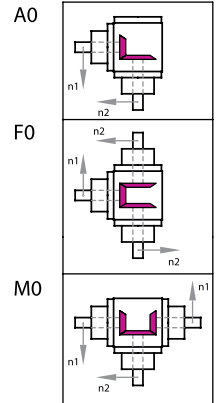

Achtung: Standardbefestigungsgewinde im Gehäuse nur an den Seiten 1, 2 & 4. Alternativ auch an den Seiten 3, 5 & 6 möglich.
Note: Standard fastening thread in the housing only on sides 1, 2 & 4. Alternatively, also possible on sides 3, 5 & 6.

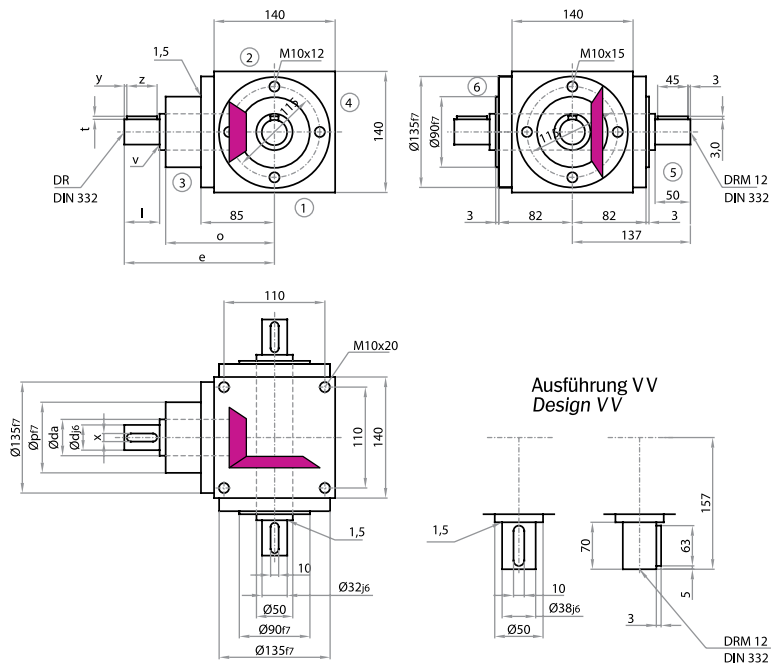

Bauart / Model

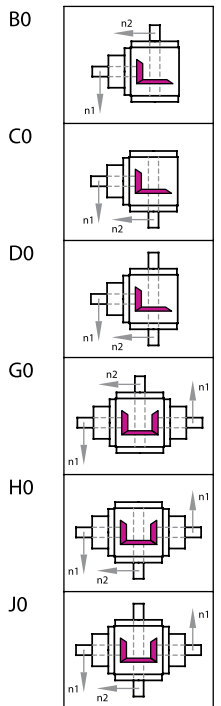

Achtung: Standardbefestigungsgewinde im Gehäuse nur an den Seiten 1, 2 & 4. Alternativ auch an den Seiten 3, 5 & 6 möglich.
Note: Standard fastening thread in the housing only on sides 1, 2 & 4. Alternatively, also possible on sides 3, 5 & 6.

Übersetzung / Transmission Ratios

Übers./Ratio	d	da	l	v	x	y	z	t	DR	e	o	p
i = 1:1 - 2:1	32	40	50	1,5	10	3	45	3	M12	180	128	90
Übers./Ratio	d	da	l	v	x	y	z	t	DR	e	o	p
i = 3:1	28	40	50	1	8	3	45	3	M10	180	128	90
Übers./Ratio	d	da	l	v	x	y	z	t	DR	e	o	p
i = 4:1	24	40	50	1	8	3	45	3	M8	195	143	85
Übers./Ratio	d	da	l	v	x	y	z	t	DR	e	o	p
i = 5:1 - 6:1	24	40	50	1	8	3	45	3	M8	195	143	85

IV Leistungen, Drehmomente / Power Ratings, Torque Ratings

[n=min-1, P=kW, T=Nm]

i =	1:1	P1N	1,5:1	P1N	2:1	P1N	3:1	P1N	4:1	P1N	5:1	P1N	6:1	P1N
n1	n2	T2N	n2	T2N	n2	T2N	n2	T2N	n2	T2N	n2	T2N	n2	T2N
3000	3000	39,68	2000	24,91	1500	16,53	1000	12,12	750	8,51	600	6,61	500	5,18
		120,00		113,00		100,00		110,00		103,00		100,00		94,00
2400	2400	37,04	1600	22,22	1200	14,68	800	11,46	600	7,34	480	5,56	400	4,58
		140,00		126,00		111,00		130,00		111,00		105,00		104,00
1500	1500	26,78	1000	17,08	750	11,41	500	8,05	375	4,96	300	3,80	250	2,95
		162,00		155,00		138,00		146,00		120,00		115,00		107,00
1000	1000	20,28	667	12,87	500	8,38	333	5,87	250	3,75	200	2,73	167	2,06
		184,00		175,00		152,00		160,00		136,00		124,00		112,00
750	750	16,20	500	10,47	375	6,86	250	4,60	187,5	3,06	150	2,15	125	1,61
		196,00		190,00		166,00		167,00		148,00		130,00		117,00
500	500	11,46	333	7,34	250	4,96	167	3,20	125	2,12	100	1,50	83	1,09
		208,00		200,00		180,00		174,00		154,00		136,00		119,00
250	250	5,92	167	3,76	125	2,62	83	1,62	62,5	1,12	50	0,79	42	0,56
		215,00		204,00		190,00		177,00		162,00		143,00		121,00
50	50	1,21	33	0,76	25	0,55	17	0,34	12,5	0,23	10	0,17	8,3	0,11
		220,00		210,00		200,00		180,00		170,00		150,00		120,00
P1Nt		10,00		10,00		10,00		10,00		10,00		10,00		10,00
T2max		430,00		210,00		320,00		280,00		280,00		250,00		200,00

Radialkräfte / Radial Forces (N)

T2 Nm	n1 (1/min)						n2 (1/min)					
	3000	1000	500	250	100	50	3000	1000	500	250	100	50
< 140	700	870	1150	1370	1700	2000	1300	1700	2000	2500	3000	3800
> 140	590	730	960	1140	1420	1670	1083	1420	1670	2080	2500	3170

Weitere Erläuterungen und verstärkte Lagerungen siehe Allgemeines / For more information and reinforced bearings, refer to general Information.
 Axialkräfte FA = 50% der Radialkräfte - siehe Allgemeines / Axial forces FA = 50% of radial forces - refer to general information.

Massenträgheitsmomente / Moments of Inertia J (kgcm²)

reduziert auf die Antriebswelle (n1) / reduced to the input shaft (n1)

Bauart Model	Übersetzung / Transmission Ratios						
	1:1	1,5:1	2:1	3:1	4:1	5:1	6:1
A0	26,2670	11,8569	8,6762	6,4356	1,8432	1,5320	1,3708
F0	39,4005	17,6940	11,9596	7,8949	2,6641	2,0574	1,7356
M0	39,4005	17,8767	14,0690	11,4119	2,8656	2,5387	2,3768
B0, C0	36,0994	18,7513	12,2785	7,9547	2,6978	2,2113	1,8426
D0	37,0815	19,1878	12,5241	8,0639	2,7592	2,2506	1,8698
G0, H0	49,2329	24,7711	17,6713	12,9310	3,7202	3,2180	2,8486
J0	50,2150	25,2076	17,9169	13,0402	3,7816	3,2573	2,8758

Getriebegewichte Gearbox Weights (kg)

Bauart Model	ca. Gewicht app. Weight
A0	19
F0	23
M0	23
B0, C0	18,5
D0	19
G0, H0	22,7
J0	23,2

V Befestigungsseite / Mounting Side

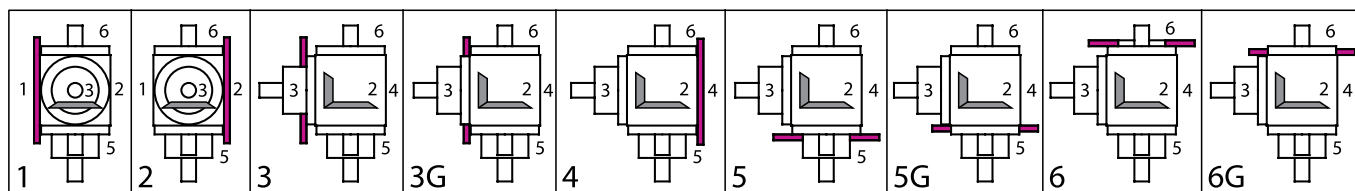

VI Einbautagen (unten liegende Getriebeseite) / Mounting Configuration (downward-facing side)

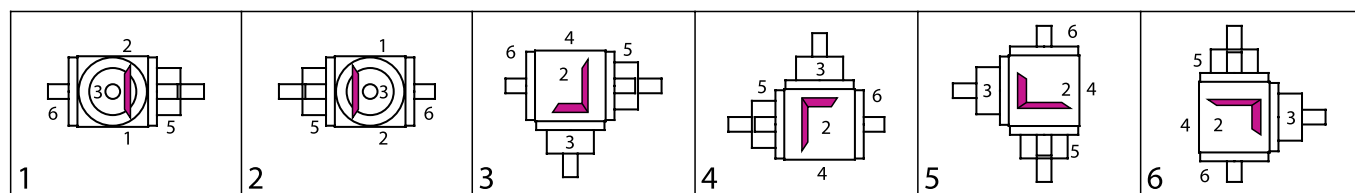

Bestellbeispiel / Example of Order

I Typ Type	Größe Size	IV Übersetzung Ratio	III Bauart Model	V Befestigungs- Mounting Side	VI Einbautage Mounting Config.	IV Drehzahl n2max Speed n2max	Ausführung Design
V	140	1:1	A0	1	1	500	0000=Standard

Kegelradgetriebe Typ V
Bevel Gearboxes Type V

Typ V 140

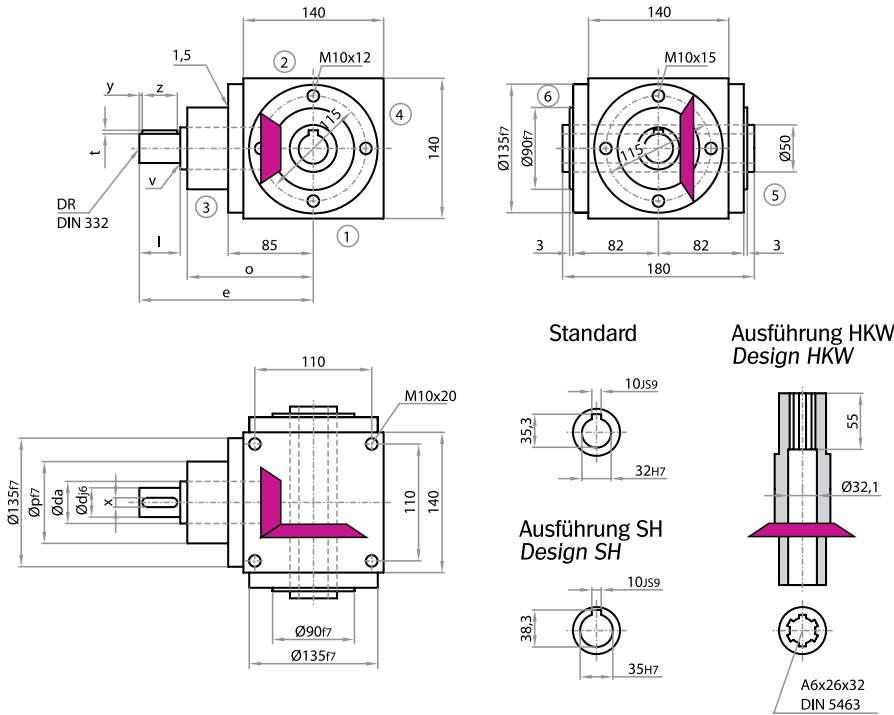

Bauart / Model

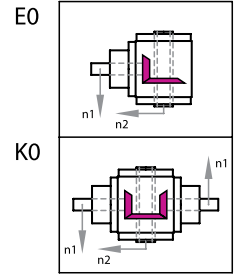

Achtung: Standardbefestigungsgewinde im Gehäuse nur an den Seiten 1, 2 & 4. Alternativ auch an den Seiten 3, 5 & 6 möglich.
Note: Standard fastening thread in the housing only on sides 1, 2 & 4. Alternatively, also possible on sides 3, 5 & 6.

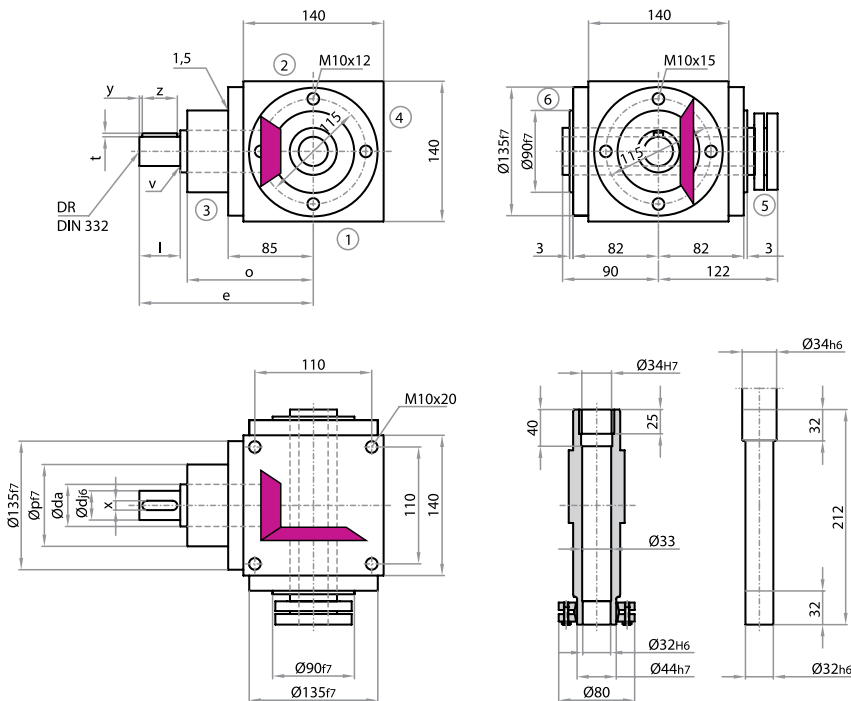

Bauart / Model

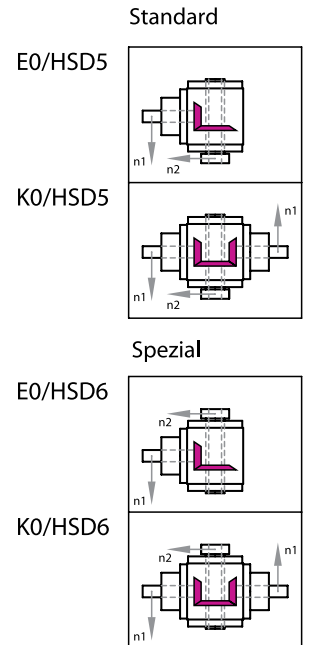

Achtung: Standardbefestigungsgewinde im Gehäuse nur an den Seiten 1, 2 & 4. Alternativ auch an den Seiten 3, 5 & 6 möglich.
Note: Standard fastening thread in the housing only on sides 1, 2 & 4. Alternatively, also possible on sides 3, 5 & 6.

Übersetzung / Transmission Ratios

Übers./Ratio	d	da	l	v	x	y	z	t	DR	e	o	p
i = 1:1 - 2:1	32	40	50	1,5	10	3	45	3	M12	180	128	90
i = 3:1	28	40	50	1	8	3	45	3	M10	180	128	90
i = 4:1	24	40	50	1	8	3	45	3	M8	195	143	85
i = 5:1 - 6:1	24	40	50	1	8	3	45	3	M8	195	143	85

IV Leistungen, Drehmomente / Power Ratings, Torque Ratings

[n = min-1, P = kW, T = Nm]

i =	1:1	P1N	1,5:1	P1N	2:1	P1N	3:1	P1N	4:1	P1N	5:1	P1N	6:1	P1N
n1	n2	T2N	n2	T2N	n2	T2N	n2	T2N	n2	T2N	n2	T2N	n2	T2N
3000	3000	39,68	2000	24,91	1500	16,53	1000	12,12	750	8,51	600	6,61	500	5,18
		120,00		113,00		100,00		110,00		103,00		100,00		94,00
2400	2400	37,04	1600	22,22	1200	14,68	800	11,46	600	7,34	480	5,56	400	4,58
		140,00		126,00		111,00		130,00		111,00		105,00		104,00
1500	1500	26,78	1000	17,08	750	11,41	500	8,05	375	4,96	300	3,80	250	2,95
		162,00		155,00		138,00		146,00		120,00		115,00		107,00
1000	1000	20,28	667	12,87	500	8,38	333	5,87	250	3,75	200	2,73	167	2,06
		184,00		175,00		152,00		160,00		136,00		124,00		112,00
750	750	16,20	500	10,47	375	6,86	250	4,60	187,5	3,06	150	2,15	125	1,61
		196,00		190,00		166,00		167,00		148,00		130,00		117,00
500	500	11,46	333	7,34	250	4,96	167	3,20	125	2,12	100	1,50	83	1,09
		208,00		200,00		180,00		174,00		154,00		136,00		119,00
250	250	5,92	167	3,76	125	2,62	83	1,62	62,5	1,12	50	0,79	42	0,56
		215,00		204,00		190,00		177,00		162,00		143,00		121,00
50	50	1,21	33	0,76	25	0,55	17	0,34	12,5	0,23	10	0,17	8,3	0,11
		220,00		210,00		200,00		180,00		170,00		150,00		120,00
P1Nt		10,00		10,00		10,00		10,00		10,00		10,00		10,00
T2max		430,00		210,00		320,00		280,00		280,00		250,00		200,00

Radialkräfte / Radial Forces (N)

FA	FR	T2 Nm	n1 (1/min)						FA	FR	n2 (1/min)					
			3000	1000	500	250	100	50			3000	1000	500	250	100	50
<	140	700	870	1150	1370	1700	2000			1300	1700	2000	2500	3000	3800	
>	140	590	730	960	1140	1420	1670			1083	1420	1670	2080	2500	3170	

Weitere Erläuterungen und verstärkte Lagerungen siehe Allgemeines / For more information and reinforced bearings, refer to general information.
 Axialkräfte FA = 50% der Radialkräfte - siehe Allgemeines / Axial forces FA = 50% of radial forces - refer to general information.

Massenträgheitsmomente / Moments of Inertia J (kgcm²)

reduziert auf die Antriebswelle (n1) / reduced to the input shaft (n1)

Bauart Model	Übersetzung / Transmission Ratios						
	1:1	1,5:1	2:1	3:1	4:1	5:1	6:1
E0	32,6630	17,2240	11,4194	7,5729	2,4830	2,0739	1,7471
K0	45,7965	23,2438	16,8122	12,5492	3,5054	3,0806	2,7531
E0/HSD	39,0643	20,0691	13,0198	8,2842	2,8831	2,3299	1,9249
K0/HSD	52,1978	26,0889	18,4126	13,2605	3,9055	3,3366	2,9309

Getriebegewichte / Gearbox Weights (kg)

Bauart Model	ca. Gewicht app. Weight
E0	18
K0	22,2
E0/HSD	18,7
K0/HSD	22,9

V Befestigungsseite / Mounting Side

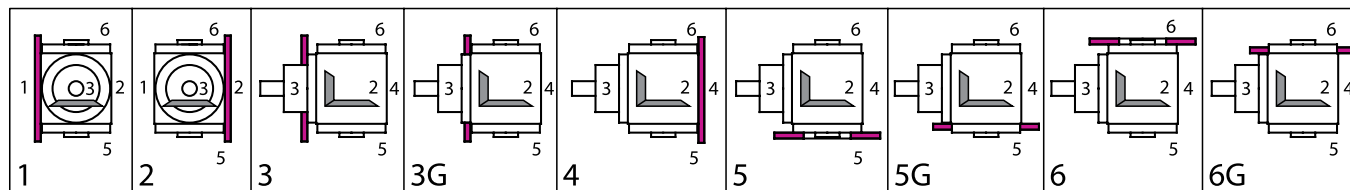

VI Einbautagen (unten liegende Getriebeseite) / Mounting Configuration (downward-facing side)

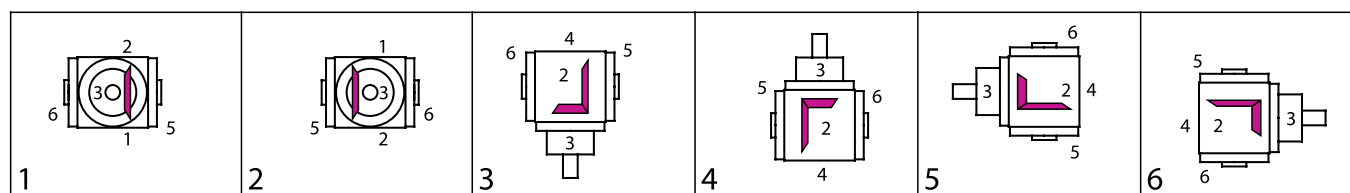

Bestellbeispiel / Example of Order

I Typ	Größe	IV Übersetzung	III Bauart	V Befestigungs-	VI Einbautage	IV Drehzahl	Ausführung
Type	Size	Ratio	Model	Mounting Side	Mounting Config.	Speed	Design
V	140	1:1	E0	1	1	500	0000=Standard

Kegelradgetriebe Type V
Bevel Gearboxes Type V

Typ V 160

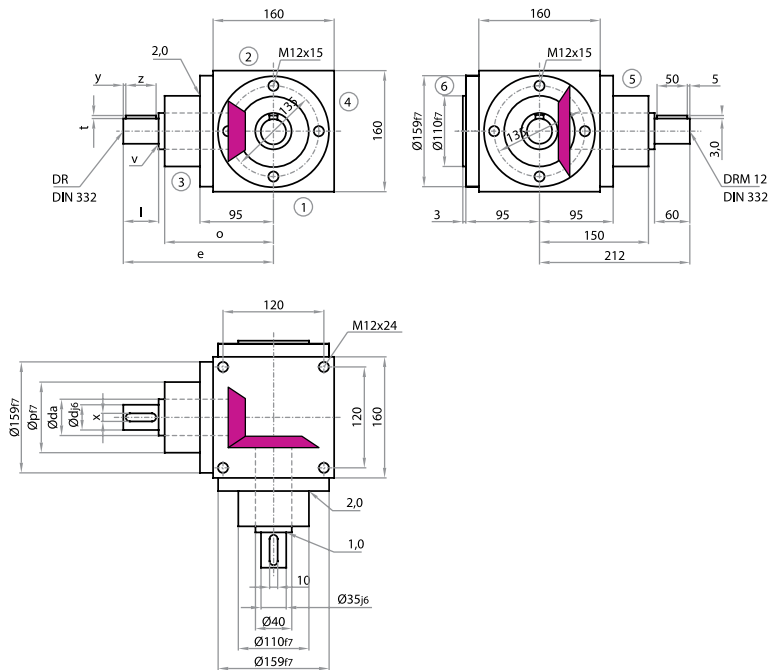

Bauart / Model

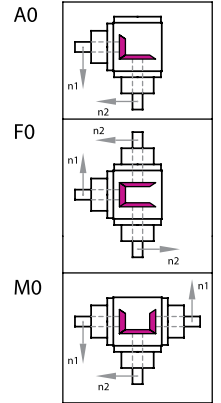

Achtung: Standardbefestigungsgewinde im Gehäuse nur an den Seiten 1, 2 & 4.
 Alternativ auch an den Seiten 3, 5 & 6 im Rastermaß 130x130 möglich.
Note: Standard fastening thread in the housing only on sides 1, 2 & 4.
 Alternatively, also possible in the grid dimension of 130x130 on sides 3, 5 & 6.

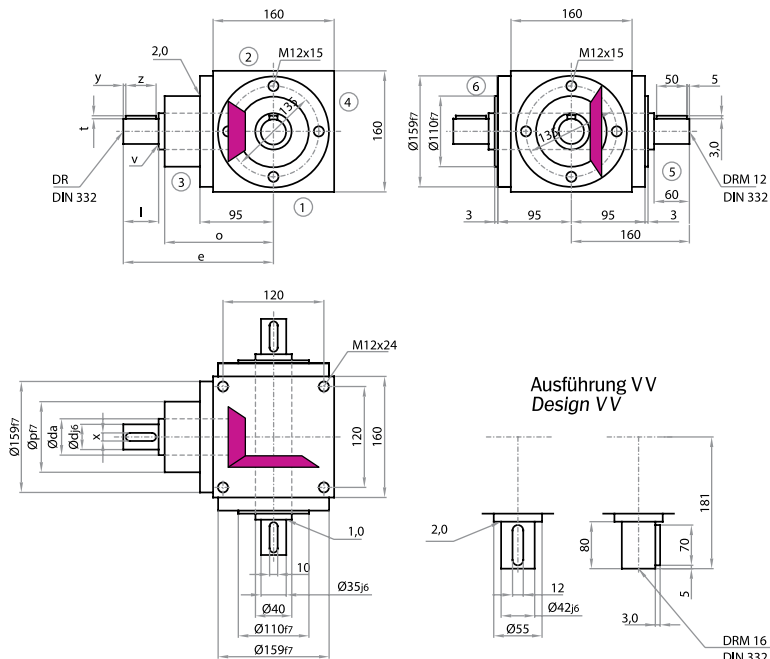

Bauart / Model

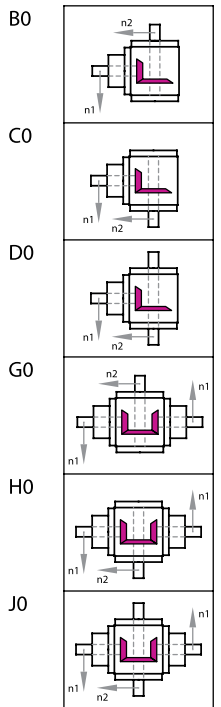

Achtung: Standardbefestigungsgewinde im Gehäuse nur an den Seiten 1, 2 & 4.
 Alternativ auch an den Seiten 3, 5 & 6 im Rastermaß 130x130 möglich.
Note: Standard fastening thread in the housing only on sides 1, 2 & 4.
 Alternatively, also possible in the grid dimension of 130x130 on sides 3, 5 & 6.

Übersetzung / Transmission Ratios

Übers./Ratio	d	da	l	v	x	y	z	t	DR	e	o	p
i = 1:1 - 2:1	35	40	60	1,5	10	5	50	3	M12	212	150	110

Übers./Ratio	d	da	l	v	x	y	z	t	DR	e	o	p
i = 3:1	28	40	60	1	8	5	50	3	M10	212	150	100

Übers./Ratio	d	da	l	v	x	y	z	t	DR	e	o	p
i = 4:1	24	40	60	1	8	5	50	3	M8	232	170	100

Übers./Ratio	d	da	l	v	x	y	z	t	DR	e	o	p
i = 5:1 - 6:1	24	25	60	0,5	8	5	50	3	M8	232	170	100

IV Leistungen, Drehmomente / Power Ratings, Torque Ratings

[n=min-1, P=kW, T=Nm]

i = n1	1:1 n2	P1N T2N	1,5:1 n2	P1N T2N	2:1 n2	P1N T2N	3:1 n2	P1N T2N	4:1 n2	P1N T2N	5:1 n2	P1N T2N	6:1 n2	P1N T2N
3000	3000	0,00 0,00	2000	40,78 185,00	1500	28,11 170,00	1000	20,94 190,00	750	14,88 180,00	600	11,90 180,00	500	7,09 129,00
2400	2400	57,67 218,00	1600	36,15 205,00	1200	25,53 193,00	800	17,81 202,00	600	13,23 200,00	480	10,48 198,00	400	5,98 136,00
1500	1500	42,99 260,00	1000	27,78 252,00	750	20,25 245,00	500	12,68 230,00	375	9,09 220,00	300	7,11 215,00	250	3,95 143,00
1000	1000	31,96 290,00	667	20,59 280,00	500	14,88 270,00	333	8,99 245,00	250	6,61 240,00	200	4,96 225,00	167	3,01 164,00
750	750	25,63 310,00	500	16,26 295,00	375	11,57 280,00	250	6,89 250,00	187,5	5,17 250,00	150	3,97 240,00	125	2,43 176,00
500	500	18,19 330,00	333	11,56 315,00	250	8,27 300,00	167	4,79 260,00	125	3,58 260,00	100	2,76 250,00	83	1,72 187,00
250	250	9,64 350,00	167	6,07 330,00	125	4,41 320,00	83	2,56 280,00	62,5	1,86 270,00	50	1,49 270,00	42	0,92 199,00
50	50	2,09 380,00	33	1,29 355,00	25	0,98 355,00	17	0,57 305,00	12,5	0,39 280,00	10	0,32 290,00	8,3	0,18 197,00
P1Nt		15,00		15,00		15,00		15,00		15,00		15,00		15,00
T2max		660,00		650,00		650,00		457,00		422,00		420,00		350,00

Radialkräfte / Radial Forces (N)

T2 Nm	n1 (1/min)						n2 (1/min)					
	3000	1000	500	250	100	50	3000	1000	500	250	100	50
< 220	1200	1600	1900	2200	2850	3300	2000	2800	3300	4000	5000	6500
> 220	1000	1340	1590	1840	2380	2750	1670	2340	2750	3340	4170	5420

Weitere Erläuterungen und verstärkte Lagerungen siehe Allgemeines / For more information and reinforced bearings, refer to general information.
 Axialkräfte FA = 50% der Radialkräfte - siehe Allgemeines / Axial forces FA = 50% of radial forces - refer to general information.

Massenträgheitsmomente / Moments of Inertia J (kgcm²)

reduziert auf die Antriebswelle (n1) / reduced to the input shaft (n1)

Bauart Model	Übersetzung / Transmission Ratios						
	1:1	1,5:1	2:1	3:1	4:1	5:1	6:1
A0	29,6710	19,6374	12,3589	8,9516	6,4348	2,2733	2,0901
F0	44,5065	26,2309	16,0678	10,6000	7,3620	2,8667	2,5022
M0	44,5065	32,6812	21,0089	16,2548	11,9424	3,9532	3,7681
B0, C0	31,5527	32,0243	20,1006	12,0803	8,4198	3,6887	2,9407
D0	32,5820	32,4818	20,3579	12,1947	8,4841	3,7299	2,9693
G0, H0	46,3882	45,0681	28,7506	19,3835	13,9274	5,3686	4,6187
J0	47,4175	45,5256	29,0079	19,4979	13,9917	5,4098	4,6473

Getriebegewichte

Gearbox Weights (kg)

Bauart Model	ca. Gewicht app. Weight
A0	28,5
F0	35
M0	35
B0, C0	28
D0	28,5
G0, H0	34,5
J0	35

V Befestigungsseite / Mounting Side

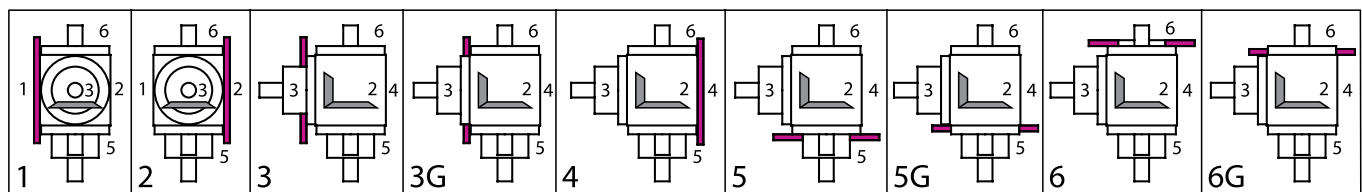

VI Einbautagen (unten liegende Getriebeseite) / Mounting Configuration (downward-facing side)

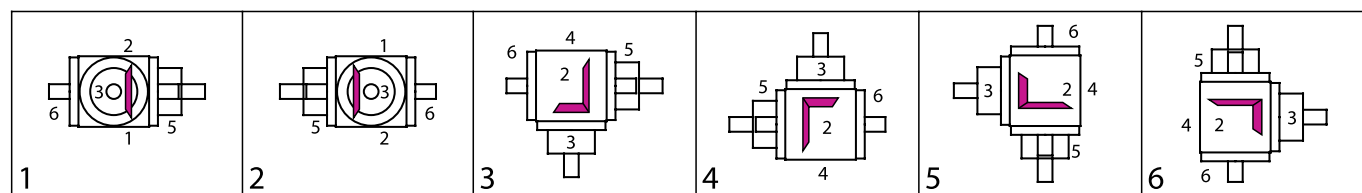

Bestellbeispiel / Example of Order

I Typ Type	Größe Size	IV Übersetzung Ratio	III Bauart Model	V Befestigungs- Mounting Side	VI Einbautage Mounting Config.	IV Drehzahl Speed	Ausführung Design
V	160	1:1	A0	1	.	400 / n2max	0000=Standard

Kegelradgetriebe Typ V
Bevel Gearboxes Type V

Typ V 160

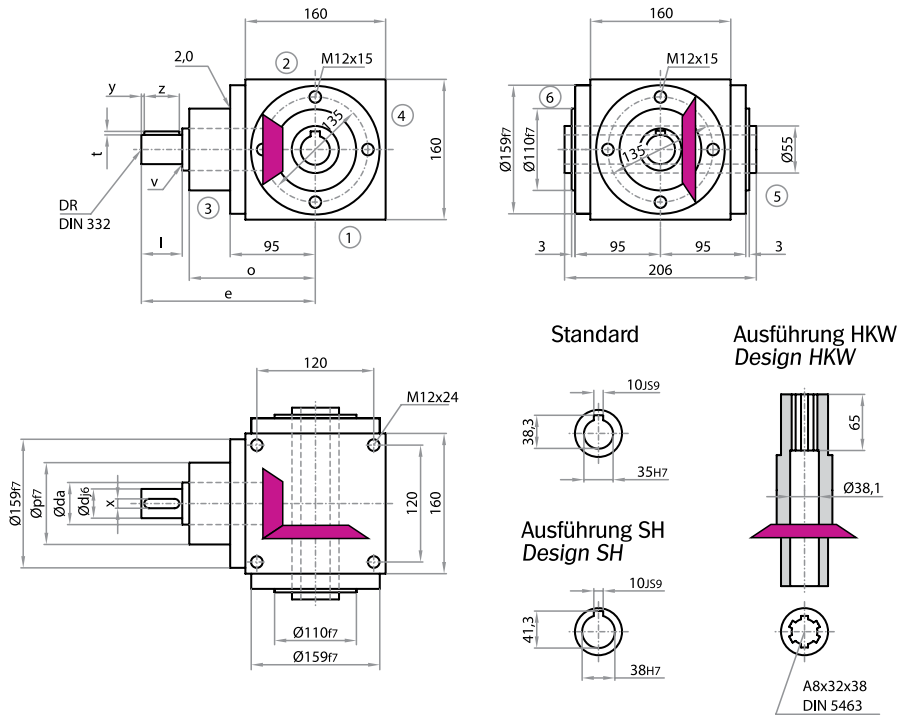

Bauart / Model

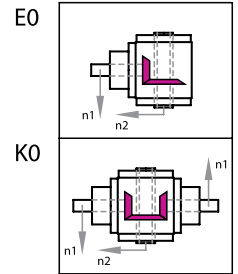

Achtung: Standardbefestigungsgewinde im Gehäuse nur an den Seiten 1, 2 & 4.
Alternativ auch an den Seiten 3, 5 & 6 im Rastermaß 130x130 möglich.

Note: Standard fastening thread in the housing only on sides 1, 2 & 4.
Alternatively, also possible in the grid dimension of 130x130 on sides 3, 5 & 6.

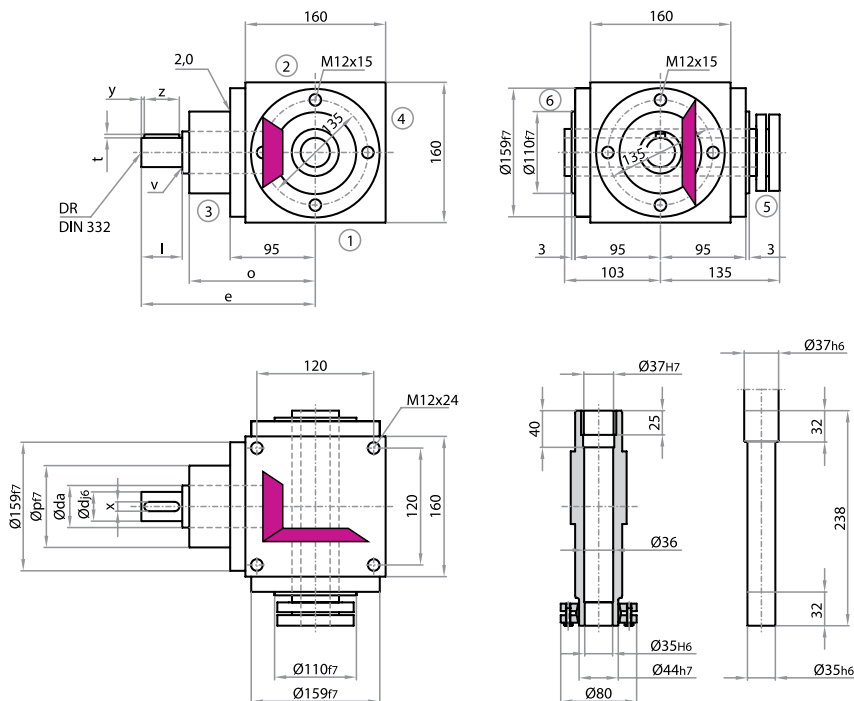

Bauart / Model

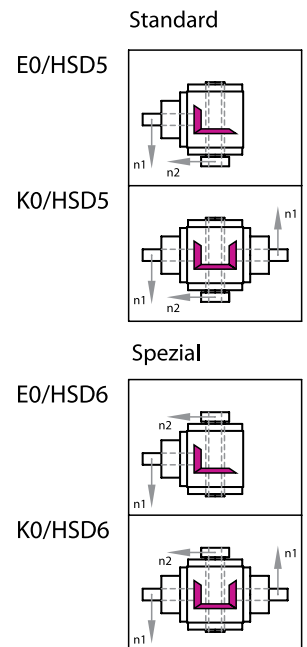

Achtung: Standardbefestigungsgewinde im Gehäuse nur an den Seiten 1, 2 & 4.
Alternativ auch an den Seiten 3, 5 & 6 im Rastermaß 130x130 möglich.

Note: Standard fastening thread in the housing only on sides 1, 2 & 4.
Alternatively, also possible in the grid dimension of 130x130 on sides 3, 5 & 6.

Übersetzung / Transmission Ratios

Übers./Ratio	d	da	l	v	x	y	z	t	DR	e	o	p	Übers./Ratio	d	da	l	v	x	y	z	t	DR	e	o	p
i = 1:1 - 2:1	35	40	60	1,5	10	5	50	3	M12	212	150	110	i = 3:1	28	40	60	1	8	5	50	3	M10	212	150	100
i = 4:1	24	40	60	1	8	5	50	3	M8	232	170	100	i = 5:1 - 6:1	24	25	60	0,5	8	5	50	3	M8	232	170	100

IV Leistungen, Drehmomente / Power Ratings, Torque Ratings

[n = min-1, P = kW, T = Nm]

i = n1	1:1 n2	P1N T2N	1,5:1 n2	P1N T2N	2:1 n2	P1N T2N	3:1 n2	P1N T2N	4:1 n2	P1N T2N	5:1 n2	P1N T2N	6:1 n2	P1N T2N
3000	3000		2000	40,78 185,00	1500	28,11 170,00	1000	20,94 190,00	750	14,88 180,00	600	11,90 180,00	500	7,09 129,00
2400	2400	57,67 218,00	1600	36,15 205,00	1200	25,53 193,00	800	17,81 202,00	600	13,23 200,00	480	10,48 198,00	400	5,98 136,00
1500	1500	42,99 260,00	1000	27,78 252,00	750	20,25 245,00	500	12,68 230,00	375	9,09 220,00	300	7,11 215,00	250	3,95 143,00
1000	1000	31,96 290,00	667	20,59 280,00	500	14,88 270,00	333	8,99 245,00	250	6,61 240,00	200	4,96 225,00	167	3,01 164,00
750	750	25,63 310,00	500	16,26 295,00	375	11,57 280,00	250	6,89 250,00	187,5	5,17 250,00	150	3,97 240,00	125	2,43 176,00
500	500	18,19 330,00	333	11,56 315,00	250	8,27 300,00	167	4,79 260,00	125	3,58 260,00	100	2,76 250,00	83	1,72 187,00
250	250	9,64 350,00	167	6,07 330,00	125	4,41 320,00	83	2,56 280,00	62,5	1,86 270,00	50	1,49 270,00	42	0,92 199,00
50	50	2,09 380,00	33	1,29 355,00	25	0,98 355,00	17	0,57 305,00	12,5	0,39 280,00	10	0,32 290,00	8,3	0,18 197,00
P1Nt		15,00		15,00		15,00		15,00		15,00		15,00		15,00
T2max		660,00		650,00		650,00		457,00		422,00		420,00		350,00

Radialkräfte / Radial Forces (N)

FA	FR	T2 Nm	n1 (1/min)						FA	FR	n2 (1/min)					
			3000	1000	500	250	100	50			3000	1000	500	250	100	50
<	220	1200	1600	1900	2200	2850	3300			2300	3100	3600	4300	5300	7000	
>	220	1000	1340	1590	1840	2380	2750			1920	2580	3000	3580	4420	5830	

Weitere Erläuterungen und verstärkte Lagerungen siehe Allgemeines / For more information and reinforced bearings, refer to general information.
 Axialkräfte FA = 50% der Radialkräfte - siehe Allgemeines / Axial forces FA = 50% of radial forces - refer to general information.

Massenträgheitsmomente / Moments of Inertia J (kgcm²)

reduziert auf die Antriebswelle (n1) / reduced to the input shaft (n1)

Bauart Model	Übersetzung / Transmission Ratios						
	1:1	1,5:1	2:1	3:1	4:1	5:1	6:1
E0	34,3851	33,1416	20,6658	12,3315	8,5611	3,7791	3,0048
K0	49,2206	46,1854	29,3158	19,6347	14,0687	5,4590	4,6828
E0/HSD	40,6750	35,9371	22,2382	13,0304	8,9542	4,0307	3,1795
K0/HSD	55,5105	48,9809	30,8882	20,3336	14,4618	5,7106	4,8575

Getriebegewichte Gearbox Weights (kg)

Bauart Model	Gewicht (kg) Weight
E0	27
K0	34
E0/HSD	27,5
K0/HSD	34,5

V Befestigungsseite / Mounting Side

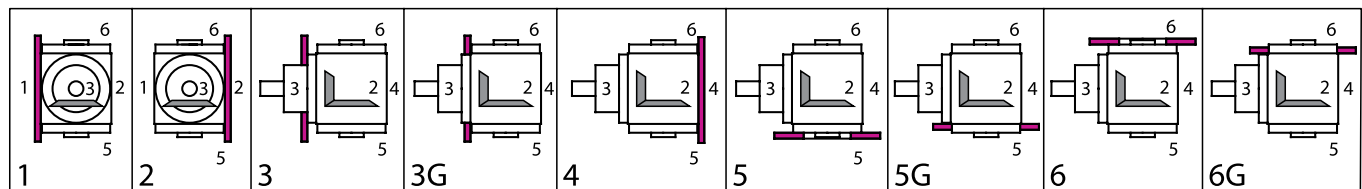

VI Einbautagen (unten liegende Getriebeseite) / Mounting Configuration (downward-facing side)

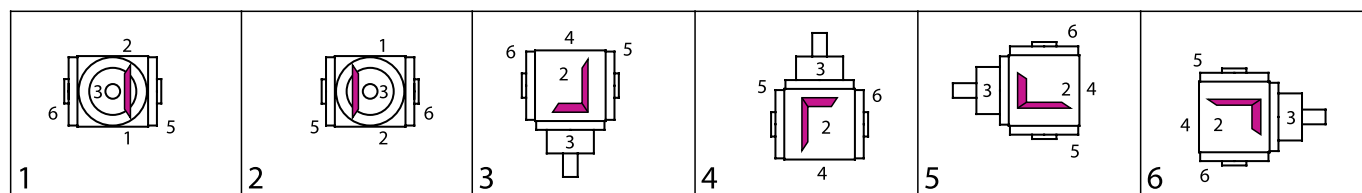

Bestellbeispiel / Example of Order

I	Typ Type	Größe Size	IV	Übersetzung Ratio	III	Bauart Model	V	Befestigungs- Mounting Side	VI	Einbautage Mounting Config.	IV	Drehzahl n2max Speed n2max	Ausführung Design
	V	160		1:1		E0		1	.	1		400 /	0000=Standard

Kegelradgetriebe Typ V
Bevel Gearboxes Type V

Typ V 200

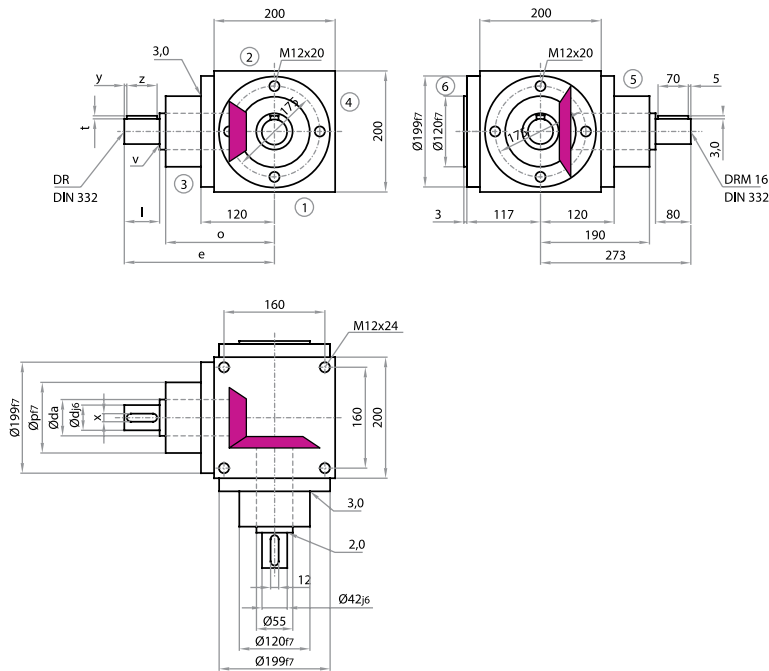

Bauart / Model

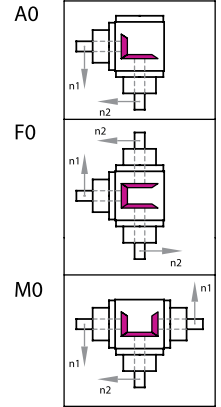

Achtung: Standardbefestigungsgewinde im Gehäuse nur an den Seiten 1, 2 & 4. Alternativ auch an den Seiten 3, 5 & 6 möglich.
Note: Standard fastening thread in the housing only on sides 1, 2 & 4. Alternatively, also possible on sides 3, 5 & 6.

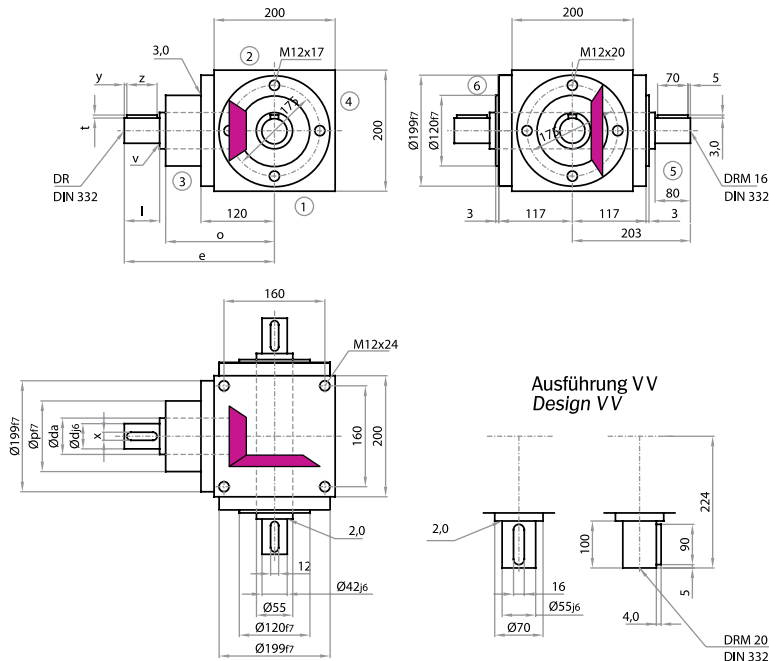

Bauart / Model

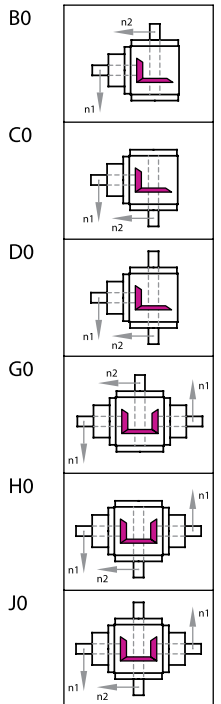

Achtung: Standardbefestigungsgewinde im Gehäuse nur an den Seiten 1, 2 & 4. Alternativ auch an den Seiten 3, 5 & 6 möglich.
Note: Standard fastening thread in the housing only on sides 1, 2 & 4. Alternatively, also possible on sides 3, 5 & 6.

Übersetzung / Transmission Ratios

Übers./Ratio	d	da	l	v	x	y	z	t	DR	e	o	p
i = 1:1 - 2:1	42	55	80	2	12	5	70	3	M16	273	190	120
i = 3:1	35	40	68	1	10	3	63	3	M12	261	190	120
Übers./Ratio	d	da	l	v	x	y	z	t	DR	e	o	p
i = 4:1	35	40	68	1	10	3	63	3	M12	261	190	120
Übers./Ratio	d	da	l	v	x	y	z	t	DR	e	o	p
i = 5:1 - 6:1	28	30	68	-	8	3	63	3	M10	261	190	110

IV Leistungen, Drehmomente / Power Ratings, Torque Ratings

[n=min-1, P=kW, T=Nm]

i = n1	1:1 n2	P1N T2N	1,5:1 n2	P1N T2N	2:1 n2	P1N T2N	3:1 n2	P1N T2N	4:1 n2	P1N T2N	5:1 n2	P1N T2N	6:1 n2	P1N T2N
3000	3000		2000	72,75 330,00	1500	51,25 310,00	1000	46,29 420,00	750	28,93 350,00	600	19,84 300,00	500	11,45 208,00
2400	2400		1600	63,49 360,00	1200	45,24 342,00	800	39,24 445,00	600	26,45 400,00	480	17,99 340,00	400	9,60 218,00
1500	1500	74,40 450,00	1000	48,17 437,00	750	35,13 425,00	500	28,38 515,00	375	18,81 455,00	300	12,57 380,00	250	6,54 237,00
1000	1000	56,21 510,00	667	37,13 505,00	500	27,56 500,00	333	20,37 555,00	250	13,36 485,00	200	9,26 420,00	167	4,74 258,00
750	750	45,88 555,00	500	30,31 550,00	375	22,32 540,00	250	15,98 580,00	187,5	10,54 510,00	150	7,27 440,00	125	3,98 289,00
500	500	34,17 620,00	333	22,57 615,00	250	16,81 610,00	167	11,04 600,00	125	7,23 525,00	100	5,18 470,00	83	2,79 304,00
250	250	19,56 710,00	167	12,70 690,00	125	9,37 680,00	83	5,76 630,00	62,5	3,79 550,00	50	2,78 505,00	42	1,44 311,00
50	50	4,13 750,00	33	2,73 750,00	25	2,07 750,00	17	1,29 690,00	12,5	0,80 580,00	10	0,58 525,00	8,3	0,28 306,00
P1Nt		26,00		26,00		26,00		26,00		26,00		26,00		26,00
T2max		1090,00		980,00		980,00		910,00		860,00		860,00		625,00

Radialkräfte / Radial Forces (N)

FA	FR	T2 Nm	n1 (1/min)						FA	FR	T2 Nm	n2 (1/min)					
			3000	1000	500	250	100	50				3000	1000	500	250	100	50
< 500			2200	1700	3200	3900	5000	6200				3200	4300	5000	6500	8000	10000
> 500			1840	1420	2670	3250	4170	5170				2670	3580	4170	5420	6670	8330

Weitere Erläuterungen und verstärkte Lagerungen siehe Allgemeines / For more information and reinforced bearings, refer to general information.
 Axialkräfte FA = 50% der Radialkräfte - siehe Allgemeines / Axial forces FA = 50% of radial forces - refer to general information.

Massenträgheitsmomente / Moments of Inertia J (kgcm²)

reduziert auf die Antriebswelle (n1) / reduced to the input shaft (n1)

Bauart Model	Übersetzung / Transmission Ratios						
	1:1	1,5:1	2:1	3:1	4:1	5:1	6:1
A0	121,2522	57,6950	36,3095	18,8322	14,2651	6,1470	5,3881
F0	181,8783	84,6400	51,4661	25,5685	18,0543	8,5721	7,0721
M0	181,8783	88,4451	57,4625	30,9282	24,7411	9,8690	9,0921
B0, C0	174,7000	103,5829	71,6215	34,1931	22,7181	12,8770	10,0616
D0	177,8173	104,9684	72,4008	34,5395	22,9130	13,0016	10,1482
G0, H0	235,3261	134,3330	92,7745	46,2891	33,1941	16,5990	13,7656
J0	238,4434	135,7185	93,5538	46,6355	33,3890	16,7236	13,8522

Getriebegewichte

Gearbox Weights (kg)

Bauart Model	ca. Gewicht app. Weight
A0	52
F0	60
M0	60
B0, C0	48
D0	50
G0, H0	58
J0	60

V Befestigungsseite / Mounting Side

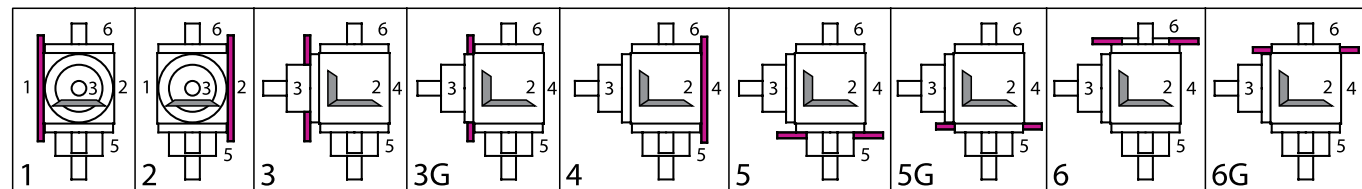

VI Einbautagen (unten liegende Getriebeseite) / Mounting Configuration (downward-facing side)

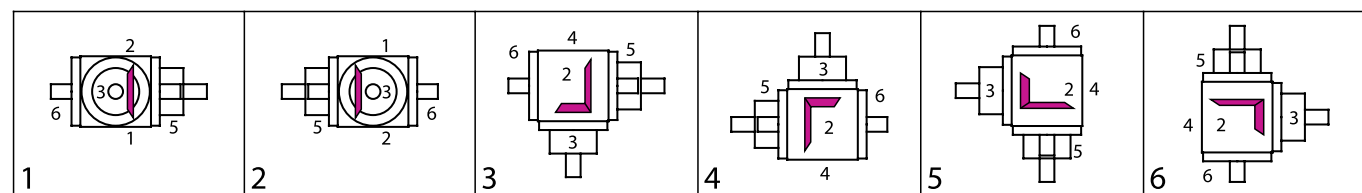

Bestellbeispiel / Example of Order

I	Typ	Größe	IV	Übersetzung	III	Bauart	V	Befestigungs-	VI	Einbautage	IV	Drehzahl	Ausführung
	Type	Size		Ratio		Model		Mounting Side		Mounting Config.		Speed	Design
	V	200		1:1		A0		1		1		300 /	0000=Standard

Kegelradgetriebe Typ V
Bevel Gearboxes Type V

Typ V 200

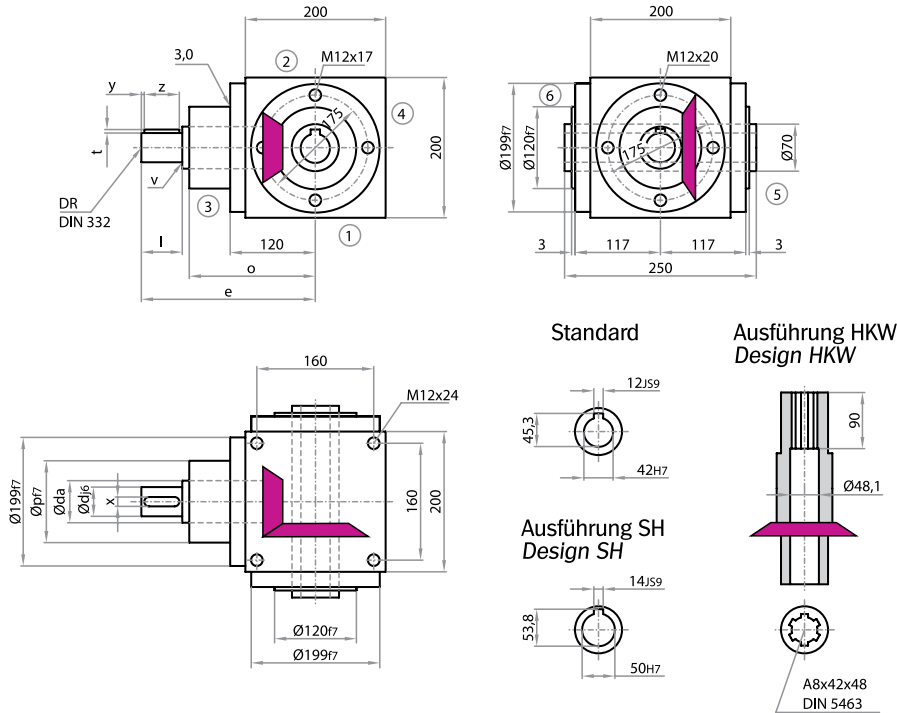

Bauart / Model

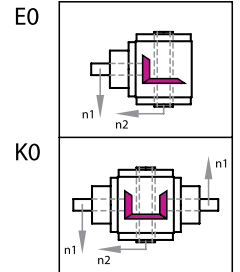

Achtung: Standardbefestigungsgewinde im Gehäuse nur an den Seiten 1, 2 & 4. Alternativ auch an den Seiten 3, 5 & 6 möglich.
Note: Standard fastening thread in the housing only on sides 1, 2 & 4. Alternatively, also possible on sides 3, 5 & 6.

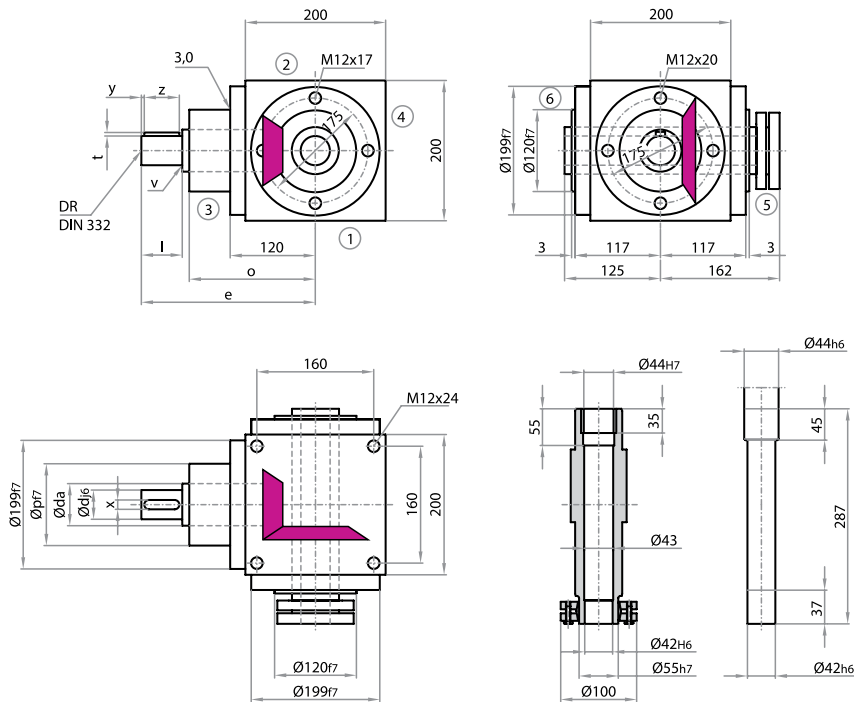

Bauart / Model

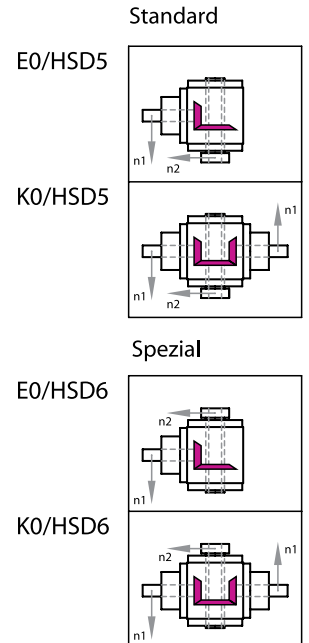

Achtung: Standardbefestigungsgewinde im Gehäuse nur an den Seiten 1, 2 & 4. Alternativ auch an den Seiten 3, 5 & 6 möglich.
Note: Standard fastening thread in the housing only on sides 1, 2 & 4. Alternatively, also possible on sides 3, 5 & 6.

Übersetzung / Transmission Ratios

Übers./Ratio	d	da	l	v	x	y	z	t	DR	e	o	p	Übers./Ratio	d	da	l	v	x	y	z	t	DR	e	o	p
i = 1:1 - 2:1	42	55	80	2	12	5	70	3	M16	273	190		i = 3:1	35	40	68	1	10	3	63	3	261	120		
i = 4:1	35	40	68	1	10	3	63	3	M12	261	190		i = 5:1 - 6:1	28	30	68	-	8	3	63	3	261	110		

IV Leistungen, Drehmomente / Power Ratings, Torque Ratings

[n = min-1, P = kW, T = Nm]

i = n1	1:1 n2	P1N T2N	1,5:1 n2	P1N T2N	2:1 n2	P1N T2N	3:1 n2	P1N T2N	4:1 n2	P1N T2N	5:1 n2	P1N T2N	6:1 n2	P1N T2N
3000	3000		2000	72,75 330,00	1500	51,25 310,00	1000	46,29 420,00	750	28,93 350,00	600	19,84 300,00	500	11,45 208,00
2400	2400		1600	63,49 360,00	1200	45,24 342,00	800	39,24 445,00	600	26,45 400,00	480	17,99 340,00	400	9,60 218,00
1500	1500	74,40 450,00	1000	48,17 437,00	750	35,13 425,00	500	28,38 515,00	375	18,81 455,00	300	12,57 380,00	250	6,54 237,00
1000	1000	56,21 510,00	667	37,13 505,00	500	27,56 500,00	333	20,37 555,00	250	13,36 485,00	200	9,26 420,00	167	4,74 258,00
750	750	45,88 555,00	500	30,31 550,00	375	22,32 540,00	250	15,98 580,00	187,5	10,54 510,00	150	7,27 440,00	125	3,98 289,00
500	500	34,17 620,00	333	22,57 615,00	250	16,81 610,00	167	11,04 600,00	125	7,23 525,00	100	5,18 470,00	83	2,79 304,00
250	250	19,56 710,00	167	12,70 690,00	125	9,37 680,00	83	5,76 630,00	62,5	3,79 550,00	50	2,78 505,00	42	1,44 311,00
50	50	4,13 750,00	33	2,73 750,00	25	2,07 750,00	17	1,29 690,00	12,5	0,80 580,00	10	0,58 525,00	8,3	0,28 306,00
P1Nt		26,00		26,00		26,00		26,00		26,00		26,00		26,00
T2max		1090,00		980,00		980,00		910,00		860,00		860,00		625,00

Radialkräfte / Radial Forces (N)

FA	T2 Nm	n1 (1/min)						n2 (1/min)					
		3000	1000	500	250	100	50	3000	1000	500	250	100	50
↖	500	2200	1700	3200	3900	5000	6200	3600	4700	5400	7200	9000	11000
↘	500	1840	1420	2670	3250	4170	5170	3000	3900	4500	6000	7500	9200

Weitere Erläuterungen und verstärkte Lagerungen siehe Allgemeines / For more information and reinforced bearings, refer to general information.
 Axialkräfte FA = 50% der Radialkräfte - siehe Allgemeines / Axial forces FA = 50% of radial forces - refer to general information.

Massenträgheitsmomente / Moments of Inertia J (kgcm²)

reduziert auf die Antriebswelle (n1) / reduced to the input shaft (n1)

Bauart Model	Übersetzung / Transmission Ratios						
	1:1	1,5:1	2:1	3:1	4:1	5:1	6:1
E0	201,3904	109,0276	76,4341	35,2209	23,3588	13,8070	10,7075
K0	262,0165	139,7777	97,5871	47,3169	33,8348	17,5290	14,4115
E0/HSD	222,4124	118,3707	81,6896	37,5567	24,6726	14,6479	11,2914
K0/HSD	283,0385	149,1208	102,8426	49,6527	35,1486	18,3699	14,9954

Getriebegewichte Gearbox Weights (kg)

Bauart Model	ca. Gewicht app. Weight
E0	48
K0	58
E0/HSD	49,3
K0/HSD	59,3

V Befestigungsseite / Mounting Side

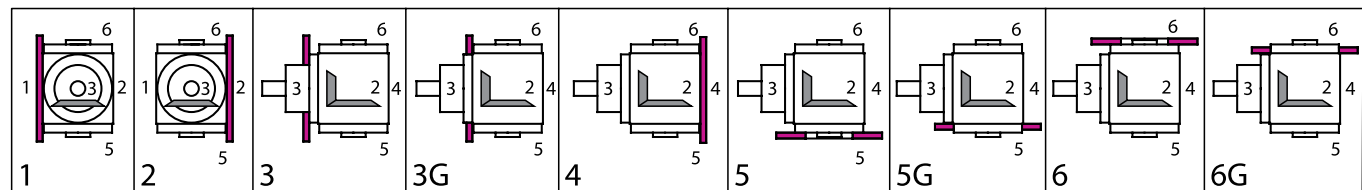

VI Einbautagen (unten liegende Getriebeseite) / Mounting Configuration (downward-facing side)

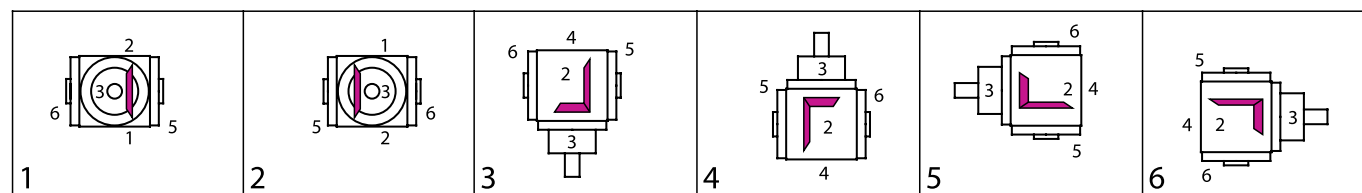

Bestellbeispiel / Example of Order

I Typ Type	Größe Size	IV Übersetzung Ratio	III Bauart Model	V Befestigungs- Mounting Side	VI Einbautage Mounting Config.	IV Drehzahl Speed	Ausführung Design
V	200	1:1	E0	1	.	300 / n2max	0000=Standard

Kegelradgetriebe Typ V
Bevel Gearboxes Type V

Typ V 230

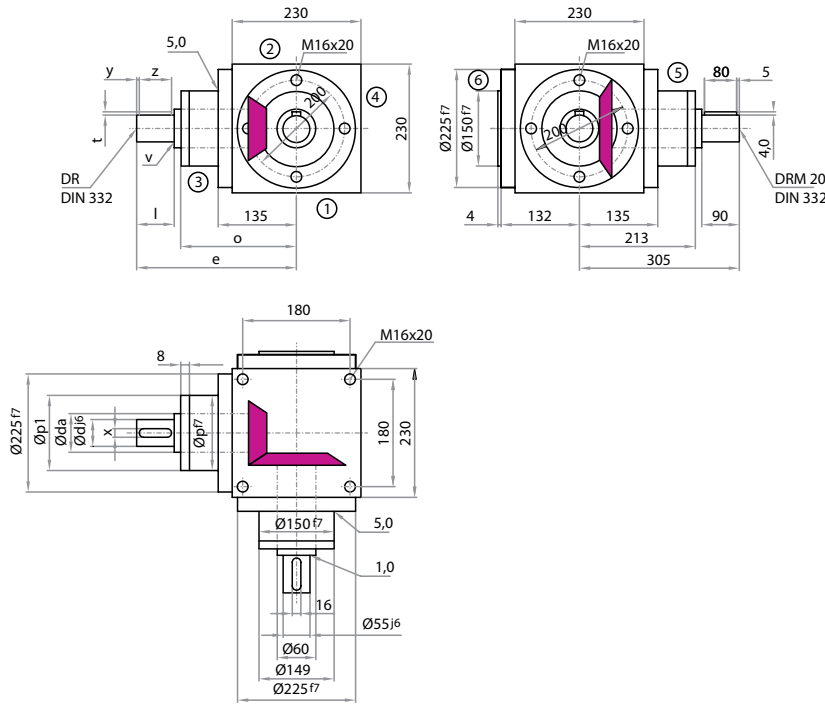

Bauart / Model

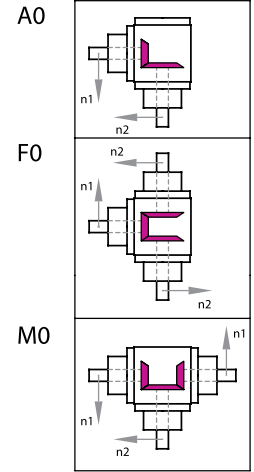

Achtung: Standardbefestigungsgewinde im Gehäuse nur an den Seiten 1, 2 & 4. Alternativ auch an den Seiten 3, 5 & 6 möglich.
Note: Standard fastening thread in the housing only on sides 1, 2 & 4. Alternatively, also possible on sides 3, 5 & 6.

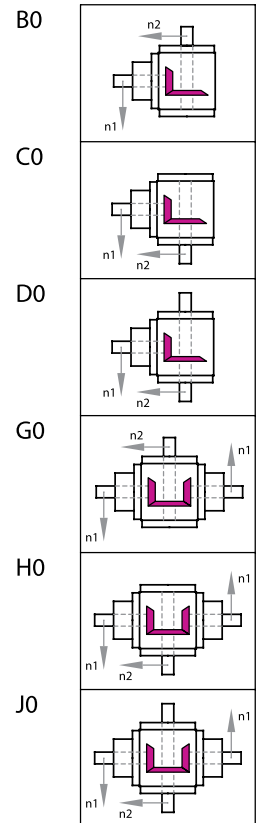
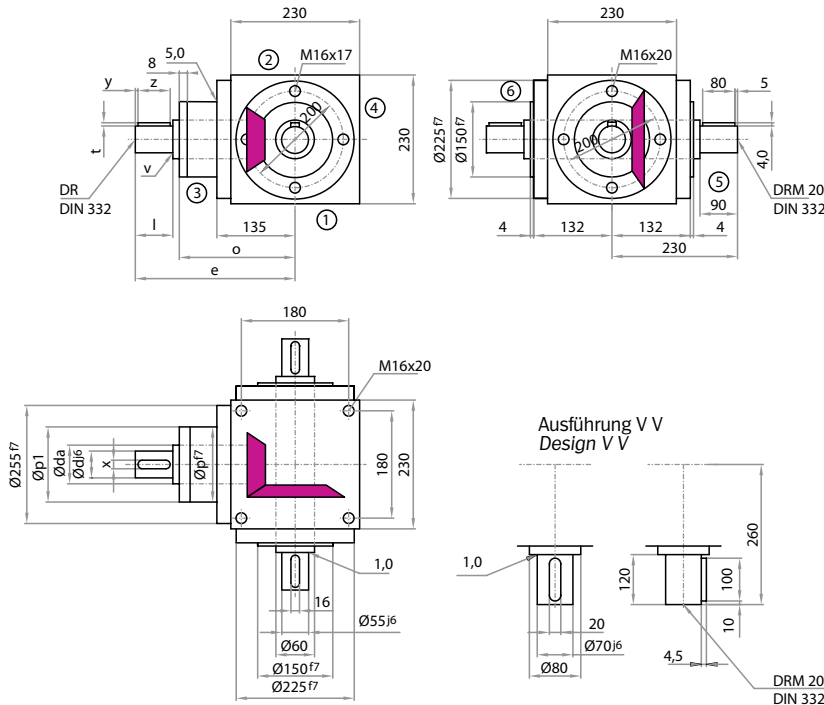

Achtung: Standardbefestigungsgewinde im Gehäuse nur an den Seiten 1, 2 & 4. Alternativ auch an den Seiten 3, 5 & 6 möglich.
Note: Standard fastening thread in the housing only on sides 1, 2 & 4. Alternatively, also possible on sides 3, 5 & 6.

Übersetzung / Transmission Ratios

Obers./Ratio	d	da	l	v	x	y	z	t	DR	e	o	p	p1
i = 1:1 - 2:1	55	60	90	1	16	5	80	2,5	M20	305	213	150	149

Obers./Ratio	d	da	l	v	x	y	z	t	DR	e	o	p	p1
i = 3:1	40	50	80	1	12	5	70	3	M16	310	228	140	139

Obers./Ratio	d	da	l	v	x	y	z	t	DR	e	o	p	p1
i = 4:1	40	50	80	1	12	0	70	3	M16	310	228	140	139

Obers./Ratio	d	da	l	v	x	y	z	t	DR	e	o	p	p1
i = 5:1 - 6:1	35	45	70	1	10	3	63	3	M16	300	228	140	139

IV Leistungen, Drehmomente / Power Ratings, Torque Ratings

[n = min-1, P = kW, T = Nm]

i = n1	1:1 n2	P1N T2N	1,5:1 n2	P1N T2N	2:1 n2	P1N T2N	3:1 n2	P1N T2N	4:1 n2	P1N T2N	5:1 n2	P1N T2N	6:1 n2	P1N T2N
3000	3000		2000	99,2 450	1500	87,63 530	1000	44,09 400	750	36,37 440	600	33,73 510	500	20,17 366
2400	2400		1600	91,35 518	1200	80,02 605	800	39,68 450	600	32,74 495	480	29,1 550	400	18,08 410
1500	1500	87,63 530	1000	72,2 655	750	59,11 715	500	29,76 540	375	24,8 600	300	21 635	250	13,5 490
1000	1000	71,65 650	667	56,21 765	500	45,19 820	333	23,33 635	250	18,6 675	200	15,76 715	167	9,92 540
750	750	60,76 735	500	45,47 825	375	36,79 890	250	19,29 700	187,5	15,19 735	150	12,73 770	125	7,78 565
500	500	45,19 820	333	33,79 920	250	26,73 970	167	14,07 765	125	10,95 795	100	9,15 830	83	5,42 590
250	250	26,73 970	167	20,57 1120	125	16,88 1225	83	7,58 825	62,5	5,99 870	50	5,07 920	42	2,82 610
50	50	7 1270	33	4,89 1330	25	3,66 1330	17	1,633 870	12,5	1,35 980	10	1,09 990	8,3	0,57 625
P1Nt		34		34		34		34		34		34		34
T2max		1500		1400		1400		1300		1300		1200		1000

Radialkräfte / Radial Forces (N)

FA	FR	T2 Nm	n1 (1/min)					n2 (1/min)					
			3000	1000	500	250	100	50	3000	1000	500	250	100
<	750	4600	5150	7200	9450	11250	13100	5850	8650	10500	12250	15000	19000
>	750	3830	4290	6000	7870	9370	10920	4870	7210	8750	10210	12500	15830

Weitere Erläuterungen und verstärkte Lagerungen siehe Allgemeines / For more information and reinforced bearings, refer to general information.
 Axialkräfte FA = 50% der Radialkräfte - siehe Allgemeines / Axial forces FA = 50% of radial forces - refer to general information.

Massenträgheitsmomente Moments of Inertia

Bauart Model	Übersetzung / Transmission Ratios						
	1:1	1,5:1	2:1	3:1	4:1	5:1	6:1
			auf Anfrage upon request				

Getriebegewichte Gearbox Weights (kg)

Bauart Model	ca. Gewicht app. Weight
A0	79
F0	97
M0	97
B0, C0	76
D0	78
G0, H0	100
J0	102

V Befestigungsseite / Mounting Side

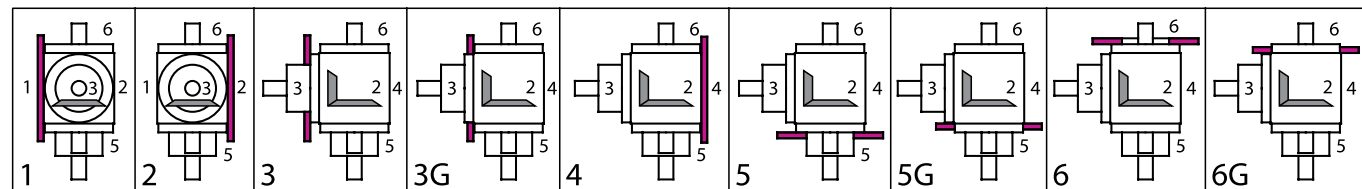

VI Einbautagen (unten liegende Getriebeseite) / Mounting Configuration (downward-facing side)

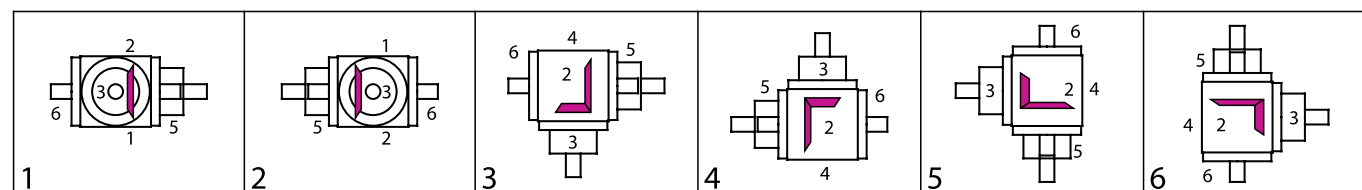

Bestellbeispiel / Example of Order

I Typ Type	Größe Size	IV Übersetzung Ratio	III Bauart Model	V Befestigungs- Mounting Side	VI Einbautage Mounting Config.	IV Drehzahl Speed	n2max n2max	Ausführung Design
V	230	1:1	A0	1	.	1	200	0000=Standard

Kegelradgetriebe Typ V
Bevel Gearboxes Type V

Typ V 230

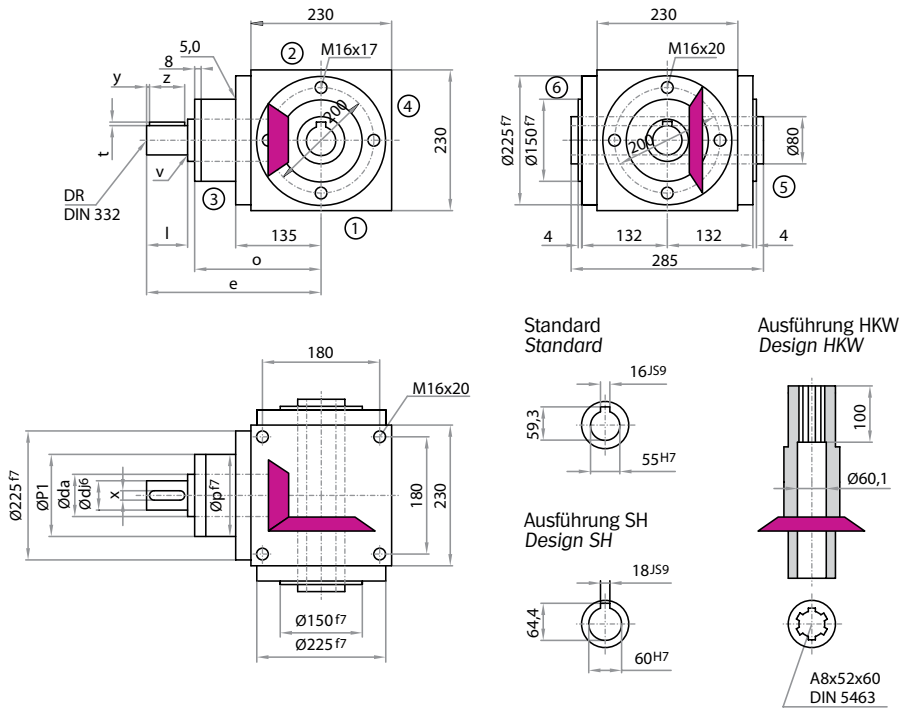

Bauart / Model

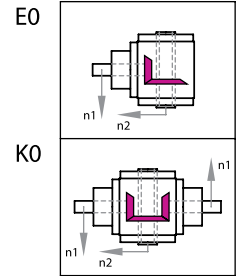

Achtung: Standardbefestigungsgewinde im Gehäuse nur an den Seiten 1, 2 & 4. Alternativ auch an den Seiten 3, 5 & 6 möglich.
Note: Standard fastening thread in the housing only on sides 1, 2 & 4. Alternatively, also possible on sides 3, 5 & 6.

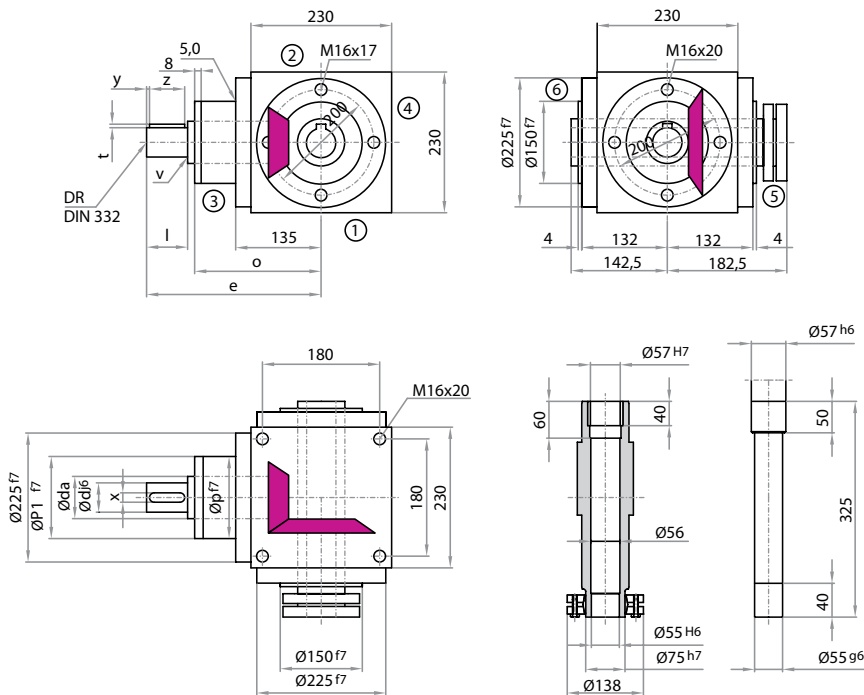

Bauart / Model

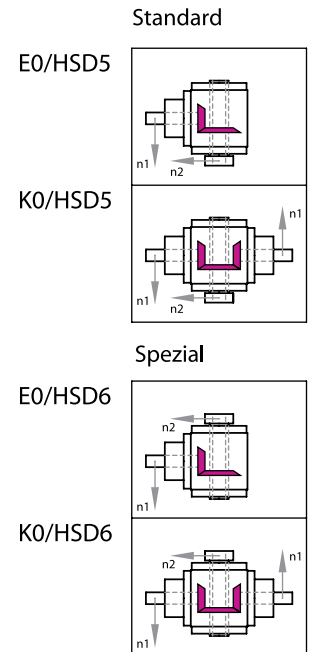

Achtung: Standardbefestigungsgewinde im Gehäuse nur an den Seiten 1, 2 & 4. Alternativ auch an den Seiten 3, 5 & 6 möglich.
Note: Standard fastening thread in the housing only on sides 1, 2 & 4. Alternatively, also possible on sides 3, 5 & 6.

Übersetzung / Transmission Ratios

Obers./Ratio	d	da	l	v	x	y	z	t	DR	e	o	p	p1
i = 1:1 - 2:1	55	60	90	1	16	5	80	2,5	M20	305	213	150	149

Obers./Ratio	d	da	l	v	x	y	z	t	DR	e	o	p	p1
i = 3:1	40	50	80	1	12	5	70	3	M16	310	228	140	139

Obers./Ratio	d	da	l	v	x	y	z	t	DR	e	o	p	p1
i = 4:1	40	50	80	1	12	0	70	3	M16	310	228	140	139

Obers./Ratio	d	da	l	v	x	y	z	t	DR	e	o	p	p1
i = 5:1 - 6:1	35	45	70	1	10	3	63	3	M16	300	228	140	139

IV Leistungen, Drehmomente / Power Ratings, Torque Ratings

[n = min-1, P = kW, T = Nm]

i = n1	1:1 n2	P1N T2N	1,5:1 n2	P1N T2N	2:1 n2	P1N T2N	3:1 n2	P1N T2N	4:1 n2	P1N T2N	5:1 n2	P1N T2N	6:1 n2	P1N T2N
3000	3000		2000	99,2 450	1500	87,63 530	1000	44,09 400	750	36,37 440	600	33,73 510	500	20,17 366
2400	2400		1600	91,35 518	1200	80,02 605	800	39,68 450	600	32,74 495	480	29,1 550	400	18,08 410
1500	1500	87,63 530	1000	72,2 655	750	59,11 715	500	29,76 540	375	24,8 600	300	21 635	250	13,5 490
1000	1000	71,65 650	667	56,21 765	500	45,19 820	333	23,33 635	250	18,6 675	200	15,76 715	167	9,92 540
750	750	60,76 735	500	45,47 825	375	36,79 890	250	19,29 700	187,5	15,19 735	150	12,73 770	125	7,78 565
500	500	45,19 820	333	33,79 920	250	26,73 970	167	14,07 765	125	10,95 795	100	9,15 830	83	5,42 590
250	250	26,73 970	167	20,57 1120	125	16,88 1225	83	7,58 825	62,5	5,99 870	50	5,07 920	42	2,82 610
50	50	7 1270	33	4,89 1330	25	3,66 1330	17	1,633 870	12,5	1,35 980	10	1,09 990	8,3	0,57 625
P1Nt		34		34		34		34		34		34		34
T2max		1500		1400		1400		1300		1300		1200		1000

Radialkräfte / Radial Forces (N)

FA	T2 Nm	n1 (1/min)						n2 (1/min)						
		3000	1000	500	250	100	50	3000	1000	500	250	100	50	
< 750	4600	5150	7200	9450	11250	13100	5850	8650	10500	12250	15000	19000		
> 750	3830	4290	6000	7870	9370	10920	4870	7210	8750	10210	12500	15830		

Weitere Erläuterungen und verstärkte Lagerungen siehe Allgemeines / For more information and reinforced bearings, refer to general Information.
 Axialkräfte FA = 50% der Radialkräfte - siehe Allgemeines / Axial forces FA = 50% of radial forces - refer to general information.

Massenträgheitsmomente Moments of Inertia

Bauart Model	Übersetzung / Transmission Ratios					
	1:1	1,5:1	2:1	3:1	4:1	5:1
	auf Anfrage upon request					

Getriebegewichte Gearbox Weights (kg)

Bauart Model	ca. Gewicht app. Weight
E0	71
K0	95
E0/HSD	72
K0/HSD	96

V Befestigungsseite / Mounting Side

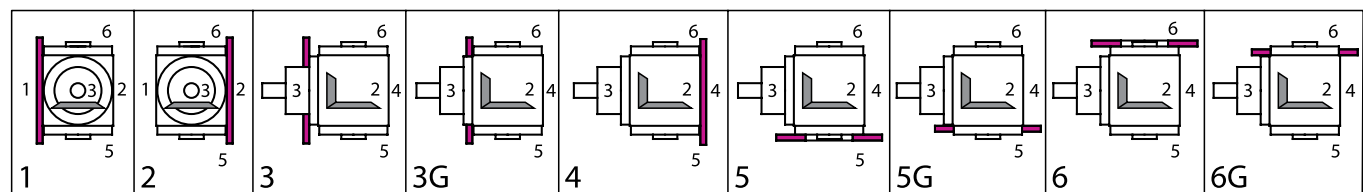

VI Einbautagen (unten liegende Getriebeseite) / Mounting Configuration (downward-facing side)

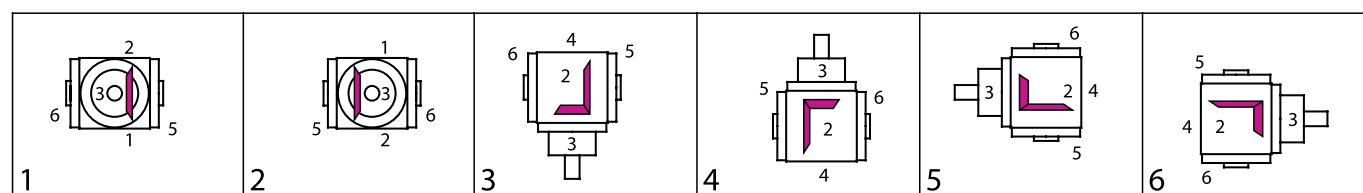

Bestellbeispiel / Example of Order

I Typ Type	Größe Size	IV Übersetzung Ratio	III Bauart Model	V Befestigungs- Mounting Side	VI Einbautage Mounting Config.	IV Drehzahl Speed	n2max n2max	Ausführung Design
V	230	1:1	E0	1	.	1	200	0000=Standard

Kegelradgetriebe Typ V
Bevel Gearboxes Type V

Typ V 260

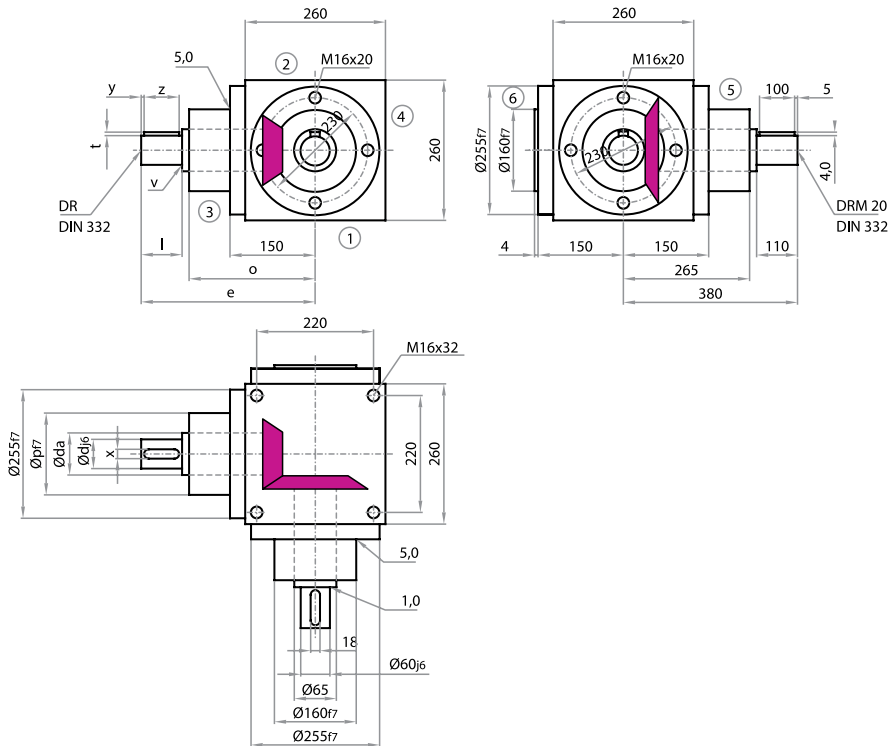

Bauart / Model

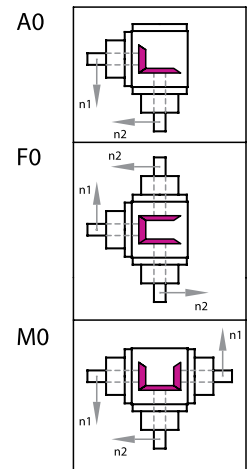

Achtung: Standardbefestigungsgewinde im Gehäuse nur an den Seiten 1, 2 & 4. Alternativ auch an den Seiten 3, 5 & 6 möglich.
Note: Standard fastening thread in the housing only on sides 1, 2 & 4. Alternatively, also possible on sides 3, 5 & 6.

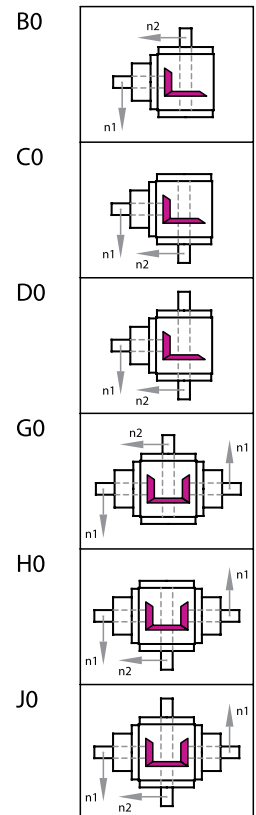
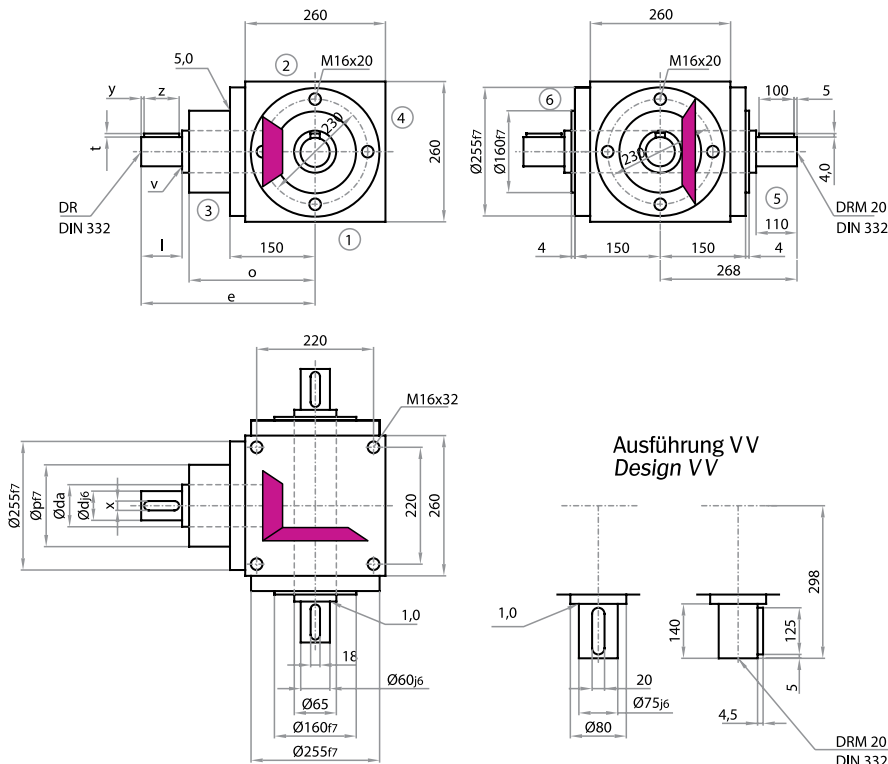

Achtung: Standardbefestigungsgewinde im Gehäuse nur an den Seiten 1, 2 & 4. Alternativ auch an den Seiten 3, 5 & 6 möglich.
Note: Standard fastening thread in the housing only on sides 1, 2 & 4. Alternatively, also possible on sides 3, 5 & 6.

Übersetzung / Transmission Ratios

Übers./Ratio	d	da	l	v	x	y	z	t	DR	e	o	p	Übers./Ratio	d	da	l	v	x	y	z	t	DR	e	o	p
i = 1:1 - 2:1	60	65	110	1	18	5	100	4	M20	380	265	160	i = 3:1	45	65	90	1,5	14	5	80	3,5	360	160		
i = 4:1	45	65	90	1,5	14	5	80	3,5	M16	360	265	160	i = 5:1 - 6:1	45	65	90	1,5	14	5	80	3,5	360	160		

IV Leistungen, Drehmomente / Power Ratings, Torque Ratings

[n=min-1, P=kW, T=Nm]

i = n1	1:1 n2	P1N T2N	1,5:1 n2	P1N T2N	2:1 n2	P1N T2N	3:1 n2	P1N T2N	4:1 n2	P1N T2N	5:1 n2	P1N T2N	6:1 n2	P1N T2N
3000	3000		2000	189,58 860,00	1500	133,92 810,00	1000	85,97 780,00	750	57,87 700,00	600	46,29 700,00	500	27,27 495,00
2400	2400		1600	158,72 900,00	1200	112,43 850,00	800	72,39 821,00	600	51,58 780,00	480	40,21 760,00	400	23,12 524,00
1500	1500	157,07 950,00	1000	104,71 950,00	750	78,53 950,00	500	49,60 900,00	375	37,20 900,00	300	29,10 880,00	250	16,36 594,00
1000	1000	115,73 1050,00	667	77,19 1050,00	500	57,87 1050,00	333	36,34 990,00	250	28,93 1050,00	200	21,82 990,00	167	12,93 702,00
750	750	96,72 1170,00	500	64,48 1170,00	375	48,36 1170,00	250	28,93 1050,00	187,5	22,73 1100,00	150	18,19 1100,00	125	10,91 792,00
500	500	72,75 1320,00	333	47,72 1300,00	250	35,27 1280,00	167	20,43 1110,00	125	16,26 1180,00	100	13,23 1200,00	83	8,06 878,00
250	250	42,44 1540,00	167	27,43 1490,00	125	20,12 1460,00	83	11,16 1220,00	62,5	8,61 1250,00	50	7,11 1290,00	42	4,35 940,00
50	50	9,64 1750,00	33	6,18 1700,00	25	4,55 1650,00	17	2,55 1360,00	12,5	1,82 1320,00	10	1,47 1330,00	8,3	0,87 951,00
P1Nt		42,00		42,00		42,00		42,00		42,00		42,00		42,00
T2max		2310,00		2100,00		2100,00		1940,00		1940,00		1910,00		1730,00

Radialkräfte / Radial Forces (N)

FA	FR	T2 Nm	n1 (1/min)						FA	FR	n2 (1/min)							
			3000	1000	500	250	100	50			3000	1000	500	250	100	50		
↙	↑		950	7000	8600	11200	15000	17500	20000	↙	↑		8500	13000	16000	18000	22000	28000
↘	↑		950	5830	7170	9330	12500	14580	16670	↘	↑		7080	10830	13330	15000	18330	23330

Weitere Erläuterungen und verstärkte Lagerungen siehe Allgemeines / For more information and reinforced bearings, refer to general information.
 Axialkräfte FA = 50% der Radialkräfte - siehe Allgemeines / Axial forces FA = 50% of radial forces - refer to general information.

Massenträgheitsmomente / Moments of Inertia J (kgcm²)

reduziert auf die Antriebswelle (n1) / reduced to the input shaft (n1)

Bauart Model	Übersetzung / Transmission Ratios						
	1:1	1,5:1	2:1	3:1	4:1	5:1	6:1
A0	814,2000	305,9333	194,2750	85,0833	46,7738	37,2840	31,8083
F0	1221,3000	486,8667	296,0500	130,3167	72,2175	53,5680	43,1167
M0	1221,3000	430,9333	286,7750	124,9333	68,1038	58,2840	52,3083
B0, CO	827,4400	168,2622	281,3350	117,2211	66,6638	50,0136	40,7039
D0	841,8500	383,5556	284,9375	52,2667	67,5644	50,5900	41,1042
G0, H0	1234,5400	293,2622	373,8350	157,0711	87,9938	71,0136	61,2039
J0	1248,9500	508,5556	377,4375	92,1167	88,8944	71,5900	61,6042

Getriebegewichte

Gearbox Weights (kg)

Bauart Model	ca. Gewicht app. Weight
A0	85
F0	105
M0	105
B0, CO	85
D0	88
G0, H0	109
J0	112

V Befestigungsseite / Mounting Side

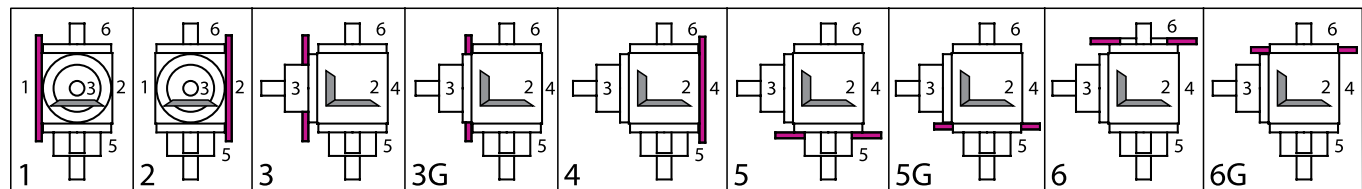

VI Einbautagen (unten liegende Getriebeseite) / Mounting Configuration (downward-facing side)

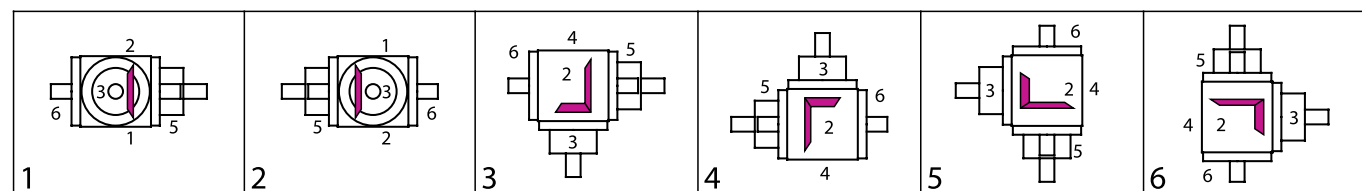

Bestellbeispiel / Example of Order

I Typ Type	Größe Size	IV Übersetzung Ratio	III Bauart Model	V Befestigungs- Mounting Side	VI Einbautage Mounting Config.	IV Drehzahl Speed	Ausführung Design
V	260	1:1	A0	1	1	200 / n2max	0000=Standard

Kegelradgetriebe Typ V
Bevel Gearboxes Type V

Typ V 260

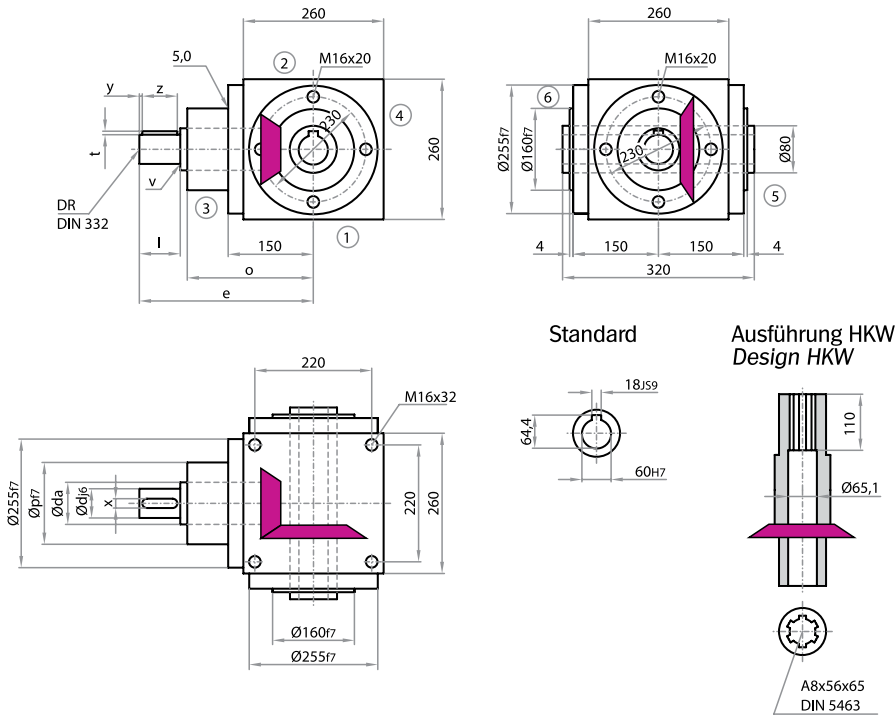

Bauart / Model

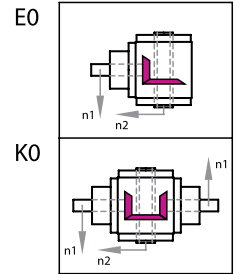

Achtung: Standardbefestigungsgewinde im Gehäuse nur an den Seiten 1, 2 & 4. Alternativ auch an den Seiten 3, 5 & 6 möglich.
Note: Standard fastening thread in the housing only on sides 1, 2 & 4. Alternatively, also possible on sides 3, 5 & 6.

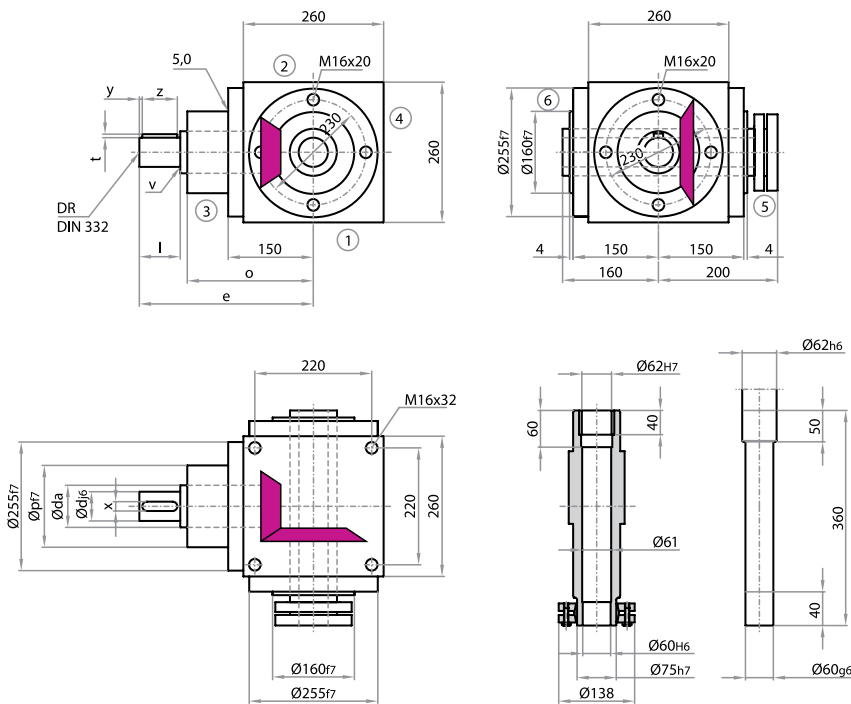

Bauart / Model

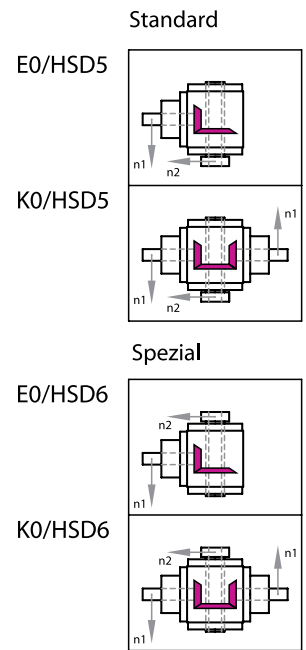

Achtung: Standardbefestigungsgewinde im Gehäuse nur an den Seiten 1, 2 & 4. Alternativ auch an den Seiten 3, 5 & 6 möglich.
Note: Standard fastening thread in the housing only on sides 1, 2 & 4. Alternatively, also possible on sides 3, 5 & 6.

Übersetzung / Transmission Ratios

Übers./Ratio	d	da	l	v	x	y	z	t	DR	e	o	p	Übers./Ratio	d	da	l	v	x	y	z	t	DR	e	o	p
i = 1:1 - 2:1	60	65	110	1	18	5	100	4	M20	380	265	160	i = 3:1	45	65	90	1,5	14	5	80	3,5	360	265	160	
i = 4:1	45	65	90	1,5	14	5	80	3,5	M16	360	265	160	i = 5:1 - 6:1	45	65	90	1,5	14	5	80	3,5	360	265	160	

IV Leistungen, Drehmomente / Power Ratings, Torque Ratings

[n = min-1, P = kW, T = Nm]

i = n1	1:1 n2	P1N T2N	1,5:1 n2	P1N T2N	2:1 n2	P1N T2N	3:1 n2	P1N T2N	4:1 n2	P1N T2N	5:1 n2	P1N T2N	6:1 n2	P1N T2N
3000	3000		2000	189,58 860,00	1500	133,92 810,00	1000	85,97 780,00	750	57,87 700,00	600	46,29 700,00	500	27,27 495,00
2400	2400		1600	158,72 900,00	1200	112,43 850,00	800	72,39 821,00	600	51,58 780,00	480	40,21 760,00	400	23,12 524,00
1500	1500	157,07 950,00	1000	104,71 950,00	750	78,53 950,00	500	49,60 900,00	375	37,20 900,00	300	29,10 880,00	250	16,36 594,00
1000	1000	115,73 1050,00	667	77,19 1050,00	500	57,87 1050,00	333	36,34 990,00	250	28,93 1050,00	200	21,82 990,00	167	12,93 702,00
750	750	96,72 1170,00	500	64,48 1170,00	375	48,36 1170,00	250	28,93 1050,00	187,5	22,73 1100,00	150	18,19 1100,00	125	10,91 792,00
500	500	72,75 1320,00	333	47,72 1300,00	250	35,27 1280,00	167	20,43 1110,00	125	16,26 1180,00	100	13,23 1200,00	83	8,06 878,00
250	250	42,44 1540,00	167	27,43 1490,00	125	20,12 1460,00	83	11,16 1220,00	62,5	8,61 1250,00	50	7,11 1290,00	42	4,35 940,00
50	50	9,64 1750,00	33	6,18 1700,00	25	4,55 1650,00	17	2,55 1360,00	12,5	1,82 1320,00	10	1,47 1330,00	8,3	0,87 951,00
P1Nt		42,00		42,00		42,00		42,00		42,00		42,00		42,00
T2max		2310,00		2100,00		2100,00		1940,00		1940,00		1910,00		1730,00

Radialkräfte / Radial Forces (N)

FA	FR	T2 Nm	n1 (1/min)					n2 (1/min)					
			3000	1000	500	250	100	50	3000	1000	500	250	100
<	950	7000	8600	11200	15000	17500	20000	8500	13000	16000	18000	22000	28000
>	950	5830	7170	9330	12500	14580	16670	7080	10830	13330	15000	18330	23330

Weitere Erläuterungen und verstärkte Lagerungen siehe Allgemeines / For more information and reinforced bearings, refer to general information.
 Axialkräfte FA = 50% der Radialkräfte - siehe Allgemeines / Axial forces FA = 50% of radial forces - refer to general information.

Massenträgheitsmomente / Moments of Inertia J (kgcm²)

reduziert auf die Antriebswelle (n1) / reduced to the input shaft (n1)

Bauart Model	Übersetzung / Transmission Ratios						
	1:1	1,5:1	2:1	3:1	4:1	5:1	6:1
E0	828,6900	413,2622	287,8975	120,1100	68,2888	51,0536	41,4261
K0	1235,7900	538,2622	380,3975	159,9600	89,6188	72,0536	61,9261
E0/HSD	892,3400	441,5511	303,8100	127,1800	72,2656	53,5988	43,1936
K0/HSD	1299,4400	566,5511	396,3100	167,0300	93,5956	74,5988	63,6936

Getriebegewichte

Gearbox Weights (kg)

Bauart Model	ca. Gewicht app. Weight
E0	82
K0	106
E0/HSD	84,9
K0/HSD	108,9

V Befestigungsseite / Mounting Side

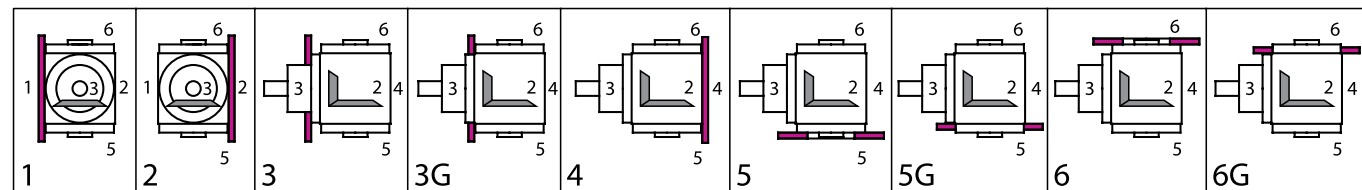

VI Einbautagen (unten liegende Getriebeseite) / Mounting Configuration (downward-facing side)

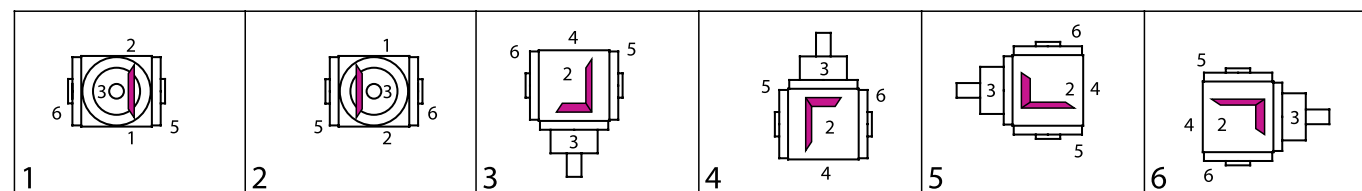

Bestellbeispiel / Example of Order

I Typ Type	Größe Size	IV Übersetzung Ratio	III Bauart Model	V Befestigungs- Mounting Side	VI Einbautage Mounting Config.	IV Drehzahl Speed	Ausführung Design
V	260	1:1	E0	1	.	1	200 / 0000=Standard

Kegelradgetriebe Typ V
Bevel Gearboxes Type V

■ Typ V 350

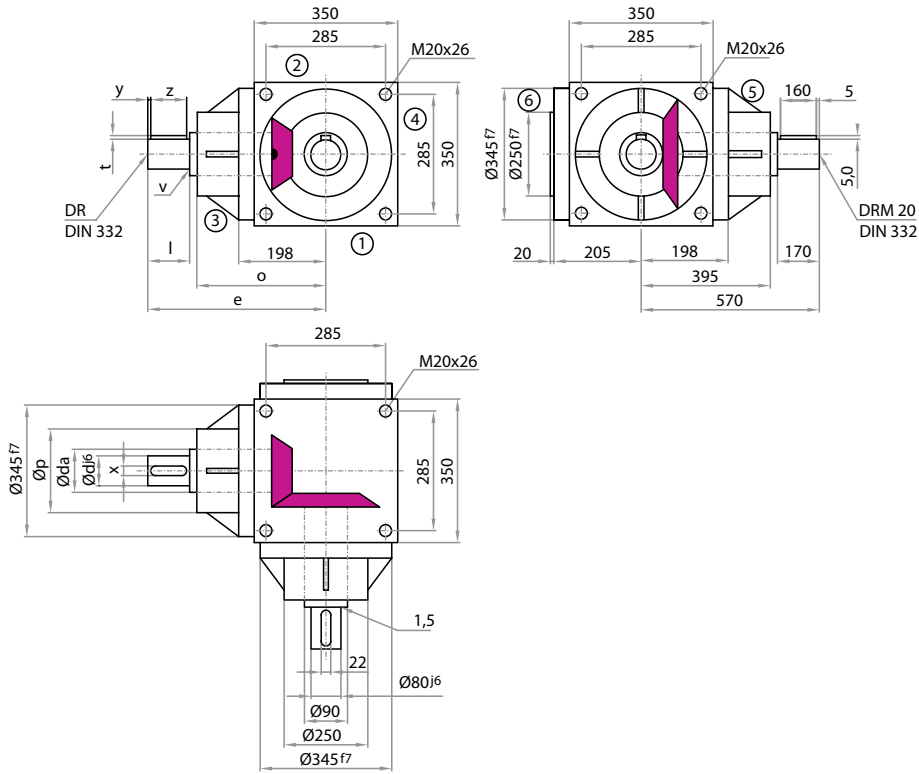

■ Bauart / Model

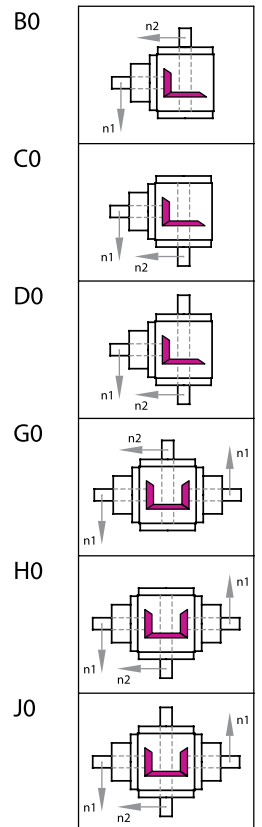
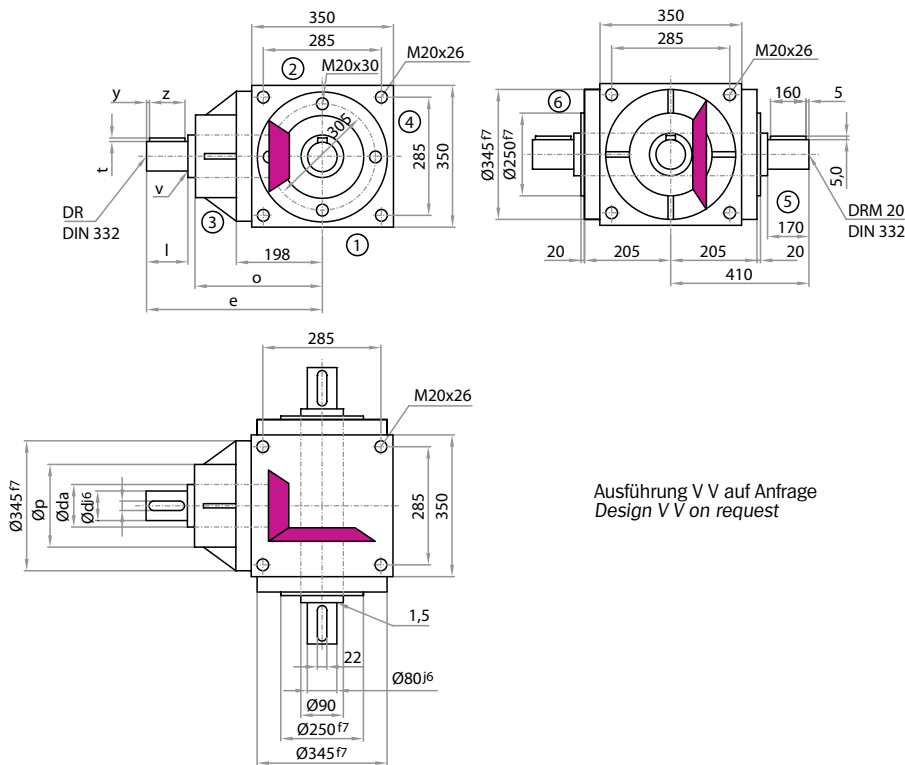
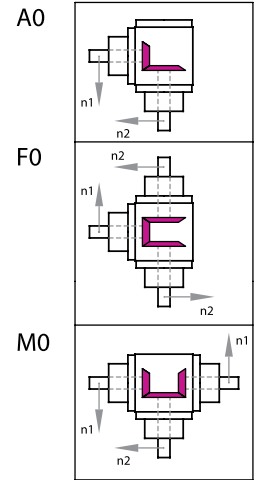

■ Übersetzung / Transmission Ratios

Obers./Ratio	d	da	l	v	x	y	z	t	DR	e	o	p	Obers./Ratio	d	da	l	v	x	y	z	t	DR	e	o	p
i = 1:1 - 2:1	80	90	170	1,5	22	5	160	5	M20	570	395	250	i = 3:1	65	90	140	1,5	18	7,5	125	4	M20	540	395	250
i = 4:1	65	90	140	1,5	18	7,5	125	4	M20	540	395	250	i = 5:1 - 6:1	55	72	110	1,5	16	10	90	4	M20	510	395	250

IV Leistungen, Drehmomente / Power Ratings, Torque Ratings

[n=min-1, P=kW, T=Nm]

i = n1	1:1 n2	P1N T2N	1,5:1 n2	P1N T2N	2:1 n2	P1N T2N	3:1 n2	P1N T2N	4:1 n2	P1N T2N	5:1 n2	P1N T2N	6:1 n2	P1N T2N
3000	3000		2000		1500		1000		750		600		500	
2400	2400		1600		1200		800	160,48 1820	600	113,75 1720	480	78,83 1490	400	56,88 1290
1500	1500	267,84 1620	1000	206,19 1870	750	200,06 2420	500	122,35 2220	375	78,95 1910	300	56,54 1710	250	41,61 1510
1000	1000	210,53 1910	667	188,55 2560	500	155,41 2820	333	96,26 2620	250	58,14 2110	200	42,33 1920	167	31,41 1710
750	750	195,92 2370	500	141,42 2560	375	129,37 3130	250	81,29 2950	187,5	47,95 2320	150	35,88 2170	125	24,25 1760
500	500	155,41 2820	333	112,63 3070	250	94,52 3430	167	59,34 3230	125	34,72 2520	100	26,67 2420	83	16,72 1820
250	250	94,52 3440	167	67,11 3650	125	54,15 3930	83	34,26 3730	62,5	19,43 2820	50	16,09 2920	42	9,28 2020
50	50	24,47 4440	33	16,34 4500	25	12,79 4640	17	7,79 4240	12,5	4,17 3030	10	3,56 3230	8,3	1,95 2120
P1Nt		90		90		90		90		90		90		90
T2max		5400		5200		5000		4500		3500		3500		2300

Radialkräfte / Radial Forces (N)

FA	FR	T2 Nm	n1 (1/min)					FA	FR	T2 Nm	n2 (1/min)				
			1500	1000	500	250	100				50	1500	1000	500	250
<	2400	14500	15000	17500	22500	27500	33000			17500	18100	21100	26150	34200	40200
>	2400	12000	12500	14500	18700	23000	27500			14500	15080	17580	21790	28500	33500

Weitere Erläuterungen und verstärkte Lagerungen siehe Allgemeines / For more information and reinforced bearings, refer to general information.
 Axialkräfte FA = 50% der Radialkräfte - siehe Allgemeines / Axial forces FA = 50% of radial forces - refer to general information.

Massenträgheitsmomente Moments of Inertia

Bauart Model	Übersetzung / Transmission Ratios						
	1:1	1,5:1	2:1	3:1	4:1	5:1	6:1
			auf Anfrage upon request				

Getriebegewichte Gearbox Weights (kg)

Bauart Model	ca. Gewicht app. Weight
A0	269
F0	340
M0	340
B0, C0	280
D0	287
G0, H0	372
J0	379

V Befestigungsseite / Mounting Side

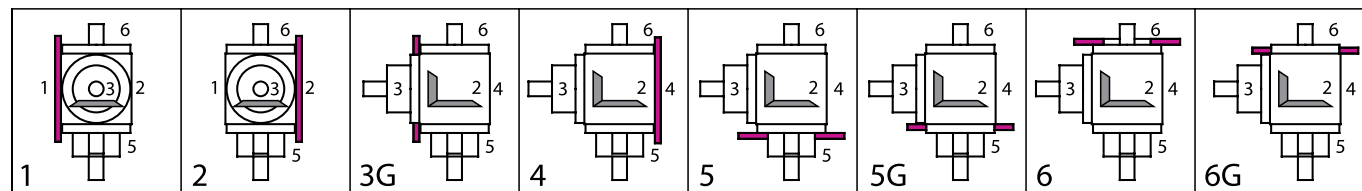

VI Einbautagen (unten liegende Getriebeseite) / Mounting Configuration (downward-facing side)

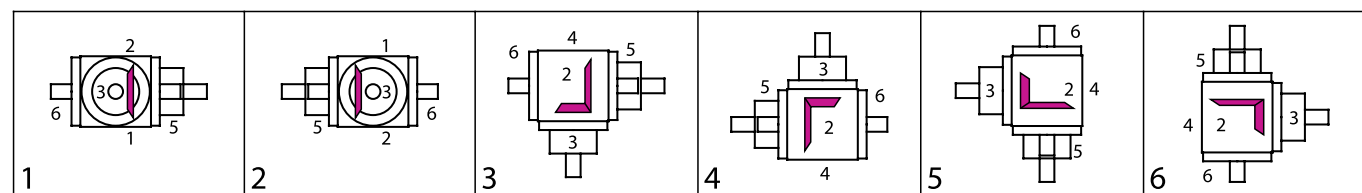

Bestellbeispiel / Example of Order

I Typ Type	Größe Size	IV Übersetzung Ratio	III Bauart Model	V Befestigungs- Mounting Side	VI Einbautage Mounting Config.	IV Drehzahl Speed	n2max n2max	Ausführung Design
V	350	1:1	A0	1	.	1	200 /	0000=Standard

Kegelradgetriebe Typ V
Bevel Gearboxes Type V

Typ V 350

Bauart / Model

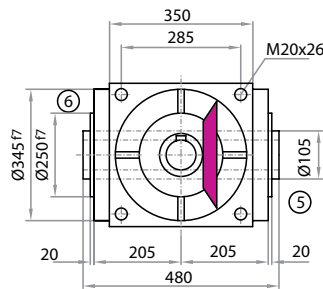
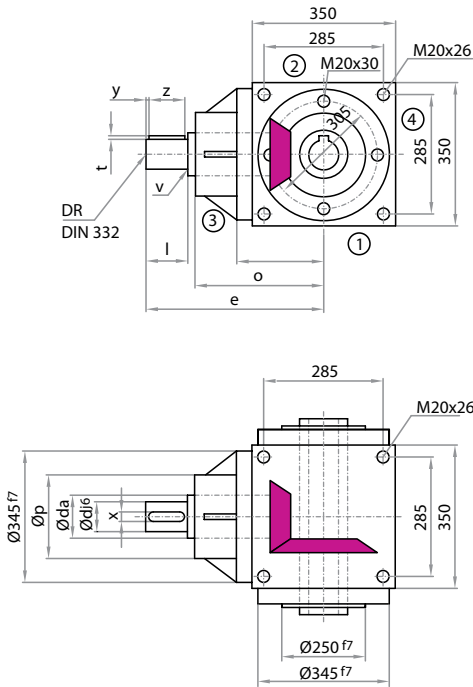

Standard
Standard

Ausführung HKW auf Anfrage
Design HKW on request

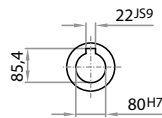

Ausführung SH auf Anfrage
Design SH on request

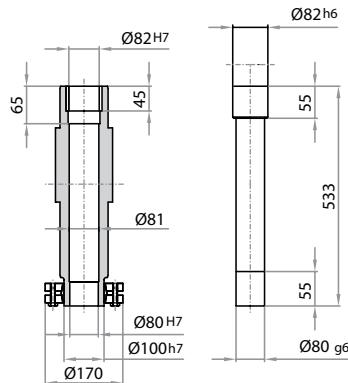
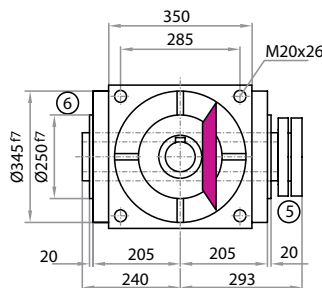
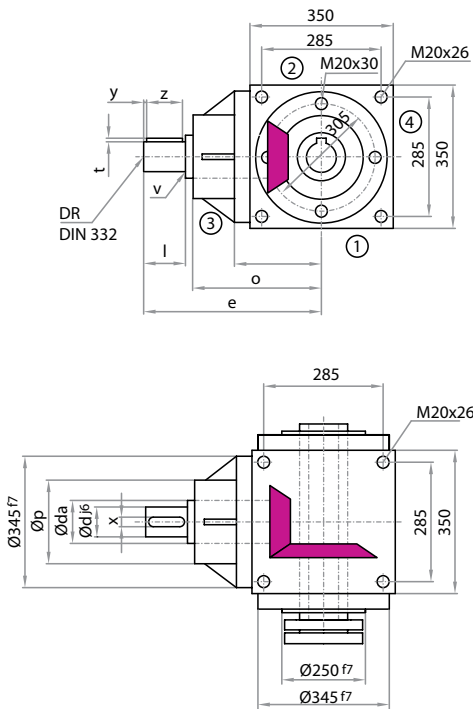
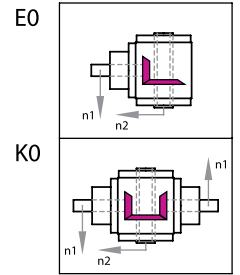

Bauart / Model

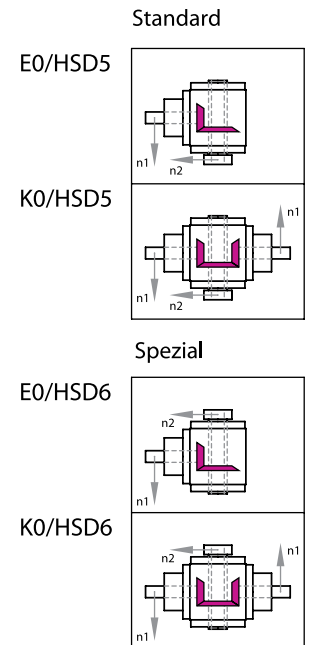

Übersetzung / Transmission Ratios

Übers./Ratio	d	da	l	v	x	y	z	t	DR	e	o	p	Übers./Ratio	d	da	l	v	x	y	z	t	DR	e	o	p
i = 1:1 - 2:1	80	90	170	1,5	22	5	160	5	M20	570	395	250	i = 3:1	65	90	140	1,5	18	7,5	125	4	M20	540	395	250
i = 4:1	65	90	140	1,5	18	7,5	125	4	M20	540	395	250	i = 5:1 - 6:1	55	72	110	1,5	16	10	90	4	M20	510	395	250

IV Leistungen, Drehmomente / Power Ratings, Torque Ratings

i =	1:1	P1N	1,5:1	P1N	2:1	P1N	3:1	P1N	4:1	P1N	5:1	P1N	6:1	P1N
n1	n2	T2N	n2	T2N	n2	T2N	n2	T2N	n2	T2N	n2	T2N	n2	T2N
3000	3000		2000		1500		1000		750		600		500	
2400	2400		1600		1200		800	160,48	600	113,75	480	78,83	400	56,88
								1820		1720		1490		1290
1500	1500	267,84	1000	206,19	750	200,06	500	122,35	375	78,95	300	56,54	250	41,61
		1620		1870		2420		2220		1910		1710		1510
1000	1000	210,53	667	188,55	500	155,41	333	96,26	250	58,14	200	42,33	167	31,41
		1910		2560		2820		2620		2110		1920		1710
750	750	195,92	500	141,42	375	129,37	250	81,29	187,5	47,95	150	35,88	125	24,25
		2370		2560		3130		2950		2320		2170		1760
500	500	155,41	333	112,63	250	94,52	167	59,34	125	34,72	100	26,67	83	16,72
		2820		3070		3430		3230		2520		2420		1820
250	250	94,52	167	67,11	125	54,15	83	34,26	62,5	19,43	50	16,09	42	9,28
		3440		3650		3930		3730		2820		2920		2020
50	50	24,47	33	16,34	25	12,79	17	7,79	12,5	4,17	10	3,56	8,3	1,95
		4440		4500		4640		4240		3030		3230		2120
P1Nt		90		90		90		90		90		90		90
T2max		5400		5200		5000		4500		3500		3500		2300

Radialkräfte / Radial Forces (N)

FA	FR	T2 Nm	n1 (1/min)						FA	FR	n2 (1/min)					
			1500	1000	500	250	100	50			1500	1000	500	250	100	50
<	2400	14500	15000	17500	22500	27500	33000			17500	18100	21100	26150	34200	40200	
>	2400	12000	12500	14500	18700	23000	27500			14500	15080	17580	21790	28500	33500	

Weitere Erläuterungen und verstärkte Lagerungen siehe Allgemeines / For more information and reinforced bearings, refer to general information.
 Axialkräfte FA = 50% der Radialkräfte - siehe Allgemeines / Axial forces FA = 50% of radial forces - refer to general information.

Massenträgheitsmomente Moments of Inertia

Bauart Model	Übersetzung / Transmission Ratios					
	1:1	1,5:1	2:1	3:1	4:1	5:1
	auf Anfrage upon request					

Getriebegewichte Gearbox Weights (kg)

Bauart Model	ca. Gewicht app. Weight
E0	259
K0	351
E0/HSD	264
K0/HSD	356

V Befestigungsseite / Mounting Side

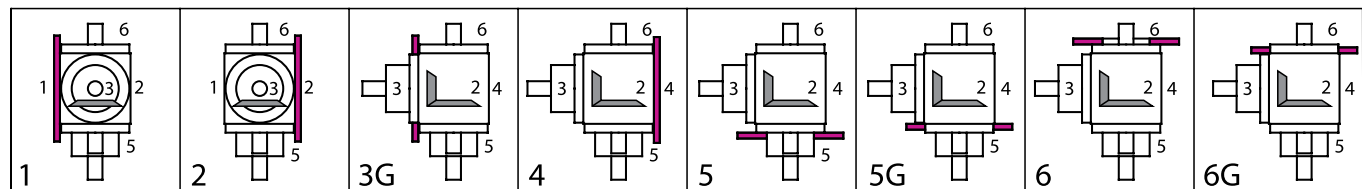

VI Einbautagen (unten liegende Getriebeseite) / Mounting Configuration (downward-facing side)

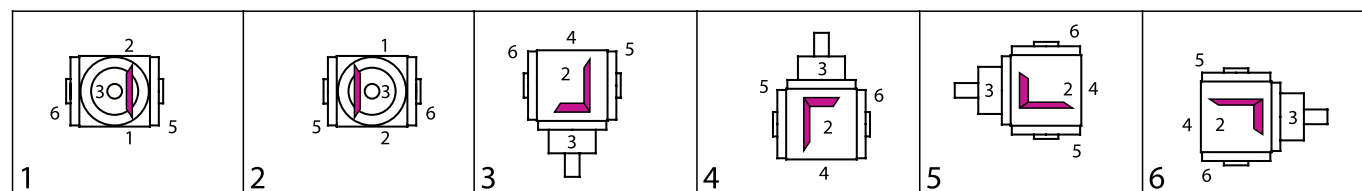

Bestellbeispiel / Example of Order

I	Typ	Größe	IV	Übersetzung	III	Bauart	V	Befestigungs-	VI	Einbautage	IV	Drehzahl	Ausführung
	Type	Size		Ratio		Model		Mounting Side		Mounting Config.		Speed	Design
	V	350		1:1		E0		1		1		200	0000=Standard

Typ VS 090

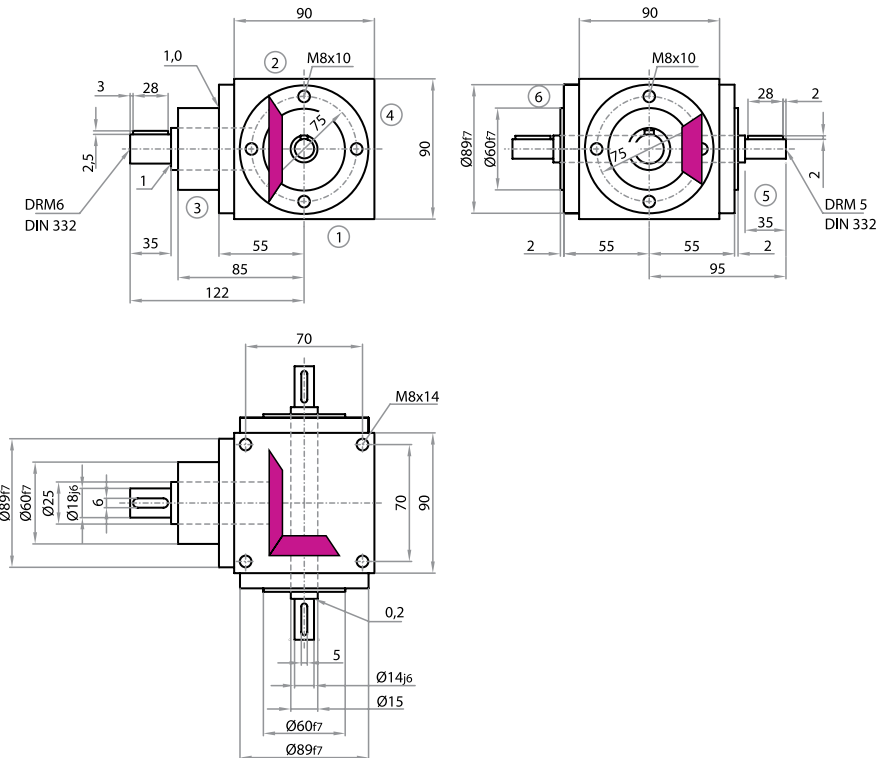

Achtung: Standardbefestigungsgewinde im Gehäuse nur an den Seiten 1, 2 & 4.

Alternativ auch an den Seiten 5 & 6 im Rastermaß 75x75 möglich.

Note: Standard fastening thread in the housing only on sides 1, 2 & 4.

Alternatively, also possible in the grid dimension of 75x75 on sides 5 & 6.

Bauart / Model

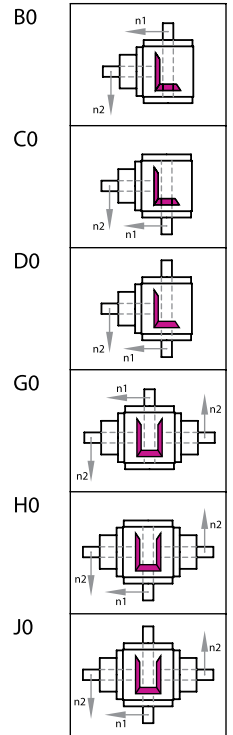

Typ VS 120

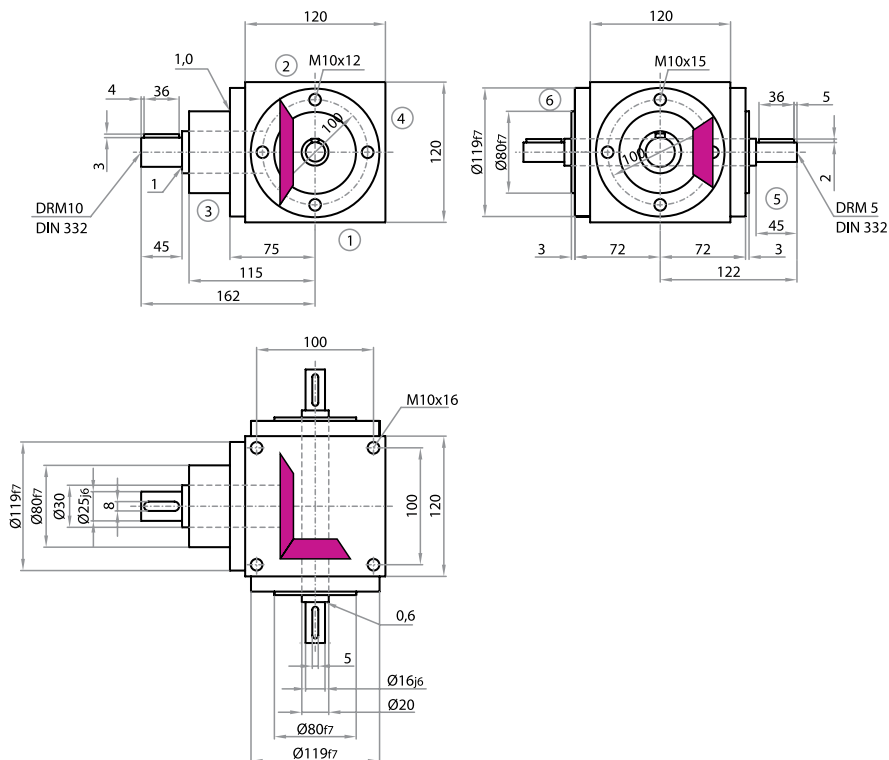

Achtung: Standardbefestigungsgewinde im Gehäuse nur an den Seiten 1, 2 & 4. Alternativ auch an den Seiten 5 & 6 möglich.

Note: Standard fastening thread in the housing only on sides 1, 2 & 4. Alternatively, also possible on sides 5 & 6.

Bauart / Model

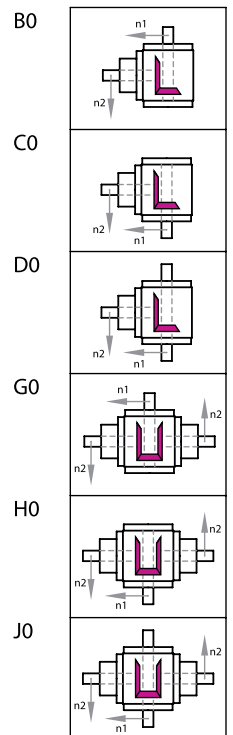

Leistungen, Drehmomente / Power Ratings, Torque Ratings [n = min-1, P = kW, T = Nm]
VS 090

i =	1,5:1	P1N	2:1	P1N
n1	n2	T2N	n2	T2N
3000	2000	5,51 25,00	1500	3,80 23,00
2400	1600	4,59 26,00	1200	3,17 24,00
1500	1000	3,20 29,00	750	2,23 27,00
1000	667	2,35 32,00	500	1,65 30,00
750	500	1,93 35,00	375	1,24 30,00
500	333	1,36 37,00	250	0,82 30,00
250	167	0,74 40,00	125	0,41 30,00
50	33	0,15 40,00	25	0,08 30,00
P1Nt		3,80		3,80
T2max		40,00		30,00

VS120

i =	1,5:1	P1N	2:1	P1N
n1	n2	T2N	n2	T2N
3000	2000	13,45 61,00	1500	9,26 56,00
2400	1600	11,46 65,00	1200	8,07 61,00
1500	1000	8,60 78,00	750	6,03 73,00
1000	667	6,32 86,00	500	4,40 80,00
750	500	5,18 94,00	375	3,30 80,00
500	333	3,70 100,00	250	2,20 80,00
250	167	1,84 100,00	125	1,10 80,00
50	33	0,37 100,00	25	0,22 80,00
P1Nt		6,20		6,20
T2max		100,00		80,00

Radialkräfte / Radial Forces (N)

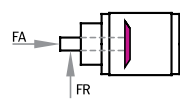

T2	n2 (1/min)						
Nm	1500	1000	500	250	100	50	
< 30	300	400	470	580	700	800	
> 30	250	330	390	490	590	670	

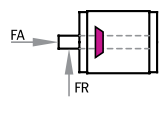

T1	n1 (1/min)						
Nm	3000	1000	500	250	100	50	
< 20	390	510	620	730	960	1150	
> 20	320	420	510	610	800	960	

Weitere Erläuterungen und verstärkte Lagerungen siehe Allgemeines
 For more information and reinforced bearings, refer to general information.

Radialkräfte / Radial Forces (N)

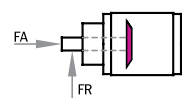

T2	n2 (1/min)						
Nm	1500	1000	500	250	100	50	
< 80	470	620	720	900	1150	1400	
> 80	390	520	600	750	960	1170	

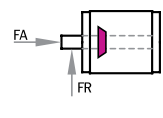

T1	n1 (1/min)						
Nm	3000	1000	500	250	100	50	
< 60	580	770	960	1150	1460	1690	
> 60	480	640	800	960	1220	1410	

Axialkräfte FA = 50% der Radialkräfte - siehe Allgemeines
 Axial forces FA = 50% of radial forces - refer to general information.

Massenträgheitsmomente Moments of Inertia J(kgcm²)
Getriebegewichte Gearbox Weights (kg)

Bauart Model	Übersetzung / Ratio		Bauart Model	ca. Gewicht app. Weight
	1,5:1	2:1		
B0, C0	0,8312	0,4858	B0, C0	5,1
D0	0,8462	0,5008	D0	5,1
			G0, H0	6,6
			J0	6,6

reduziert auf die Antriebswelle (n1)
 reduced to the input shaft (n1)

Massenträgheitsmomente Moments of Inertia J(kgcm²)
Getriebegewichte Gearbox Weights (kg)

Bauart Model	Übersetzung / Ratio		Bauart Model	ca. Gewicht app. Weight
	1,5:1	2:1		
B0, C0	3,6203	2,0872	B0, C0	11,5
D0	3,6615	2,1284	D0	11,5
			G0, H0	15
			J0	15

reduziert auf die Antriebswelle (n1)
 reduced to the input shaft (n1)

Befestigungsseite / Mounting Side

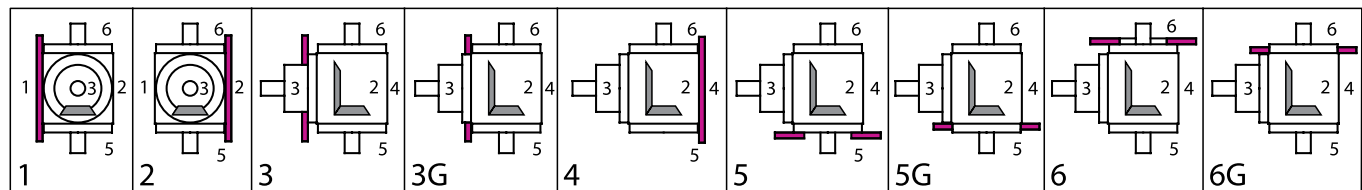

Einbaulagen (unten liegende Getriebeseite) / Mounting Configuration (downward-facing side)

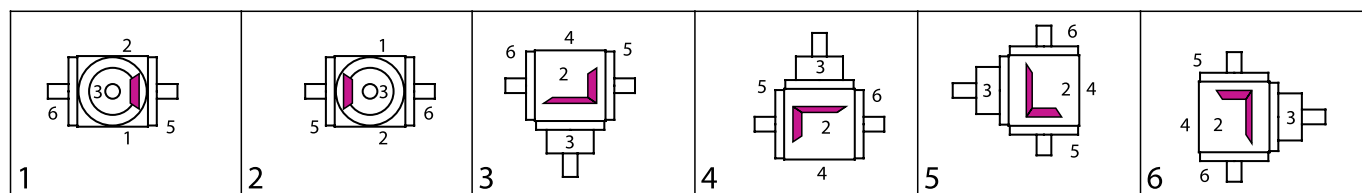

Bestellbeispiel / Example of Order

I Typ Type	Größe Size	IV Übersetzung Ratio	III Bauart Model	V Befestigungs- Mounting Side	VI Einbaulage Mounting Config.	IV Drehzahl n2max Speed n2max	Ausführung Design
VS	090	2:1	D0	1	.	500	0000=Standard

Typ VS 140

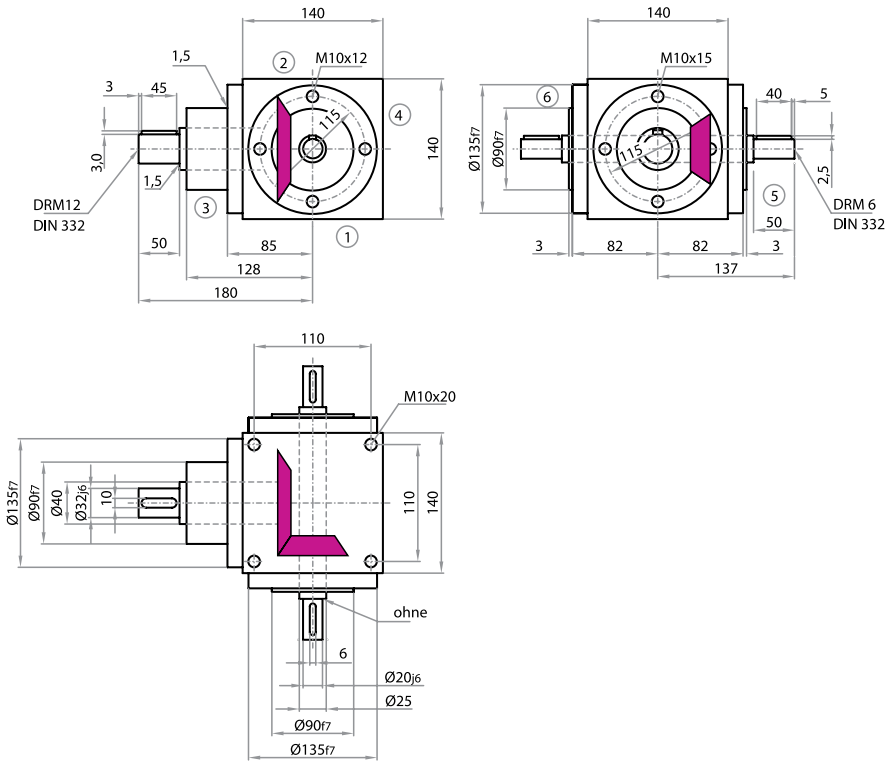

Achtung: Standardbefestigungsgewinde im Gehäuse nur an den Seiten 1, 2 & 4. Alternativ auch an den Seiten 5 & 6 möglich.
Note: Standard fastening thread in the housing only on sides 1, 2 & 4. Alternatively, also possible on sides 5 & 6.

Bauart / Model

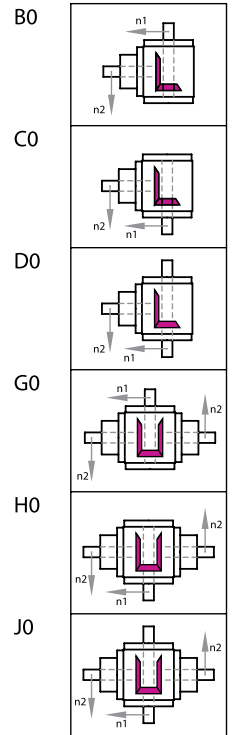

Typ VS 160

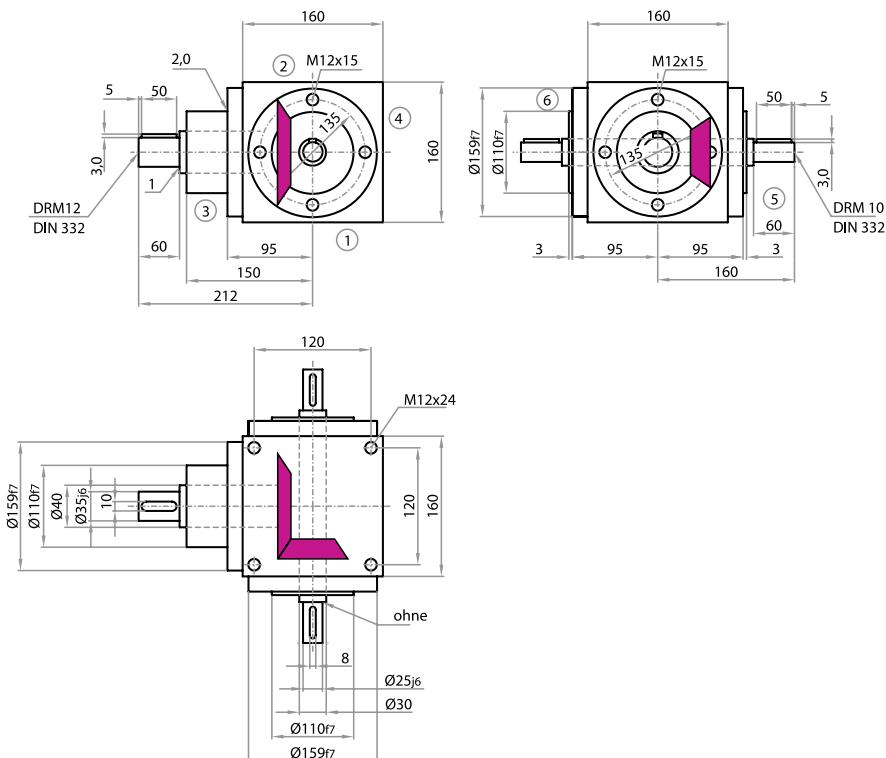

Achtung: Standardbefestigungsgewinde im Gehäuse nur an den Seiten 1, 2 & 4.
 Alternativ auch an den Seiten 5 & 6 im Rastermaß 130x130 möglich.
Note: Standard fastening thread in the housing only on sides 1, 2 & 4.
 Alternatively, also possible in the grid dimension of 130x130 on sides 5 & 6.

Bauart / Model

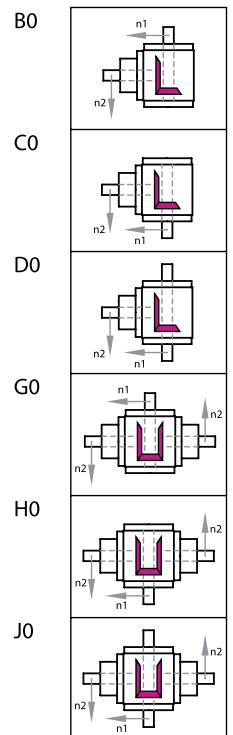

Leistungen, Drehmomente / Power Ratings, Torque Ratings [n = min-1, P = kW, T = Nm]
VS 140 VS 160

i =	1,5:1	P1N	2:1	P1N
n1	n2	T2N	n2	T2N
3000	2000	24,91 113	1500	16,53 100
2400	1600	22,22 126	1200	14,68 111
1500	1000	17,08 155	750	11,41 138
1000	667	12,87 175	500	8,38 152
750	500	10,47 190	375	6,86 166
500	333	7,34 200	250	4,96 180
250	167	3,76 204	125	2,48 180
50	33	0,76 210	25	0,5 180
P1Nt		10,00		10,00
T2max		210,00		180,00

i =	1,5:1	P1N	2:1	P1N
n1	n2	T2N	n2	T2N
3000	2000	40,78 185	1500	28,11 170
2400	1600	36,15 205	1200	25,53 193
1500	1000	27,78 252	750	20,25 245
1000	667	20,59 280	500	14,88 270
750	500	16,26 295	375	11,57 280
500	333	11,56 315	250	8,27 300
250	167	6,07 330	125	4,41 320
50	33	1,29 355	25	0,88 320
P1Nt		15,00		15,00
T2max		360,00		320,00

Radialkräfte / Radial Forces (N)

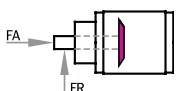

T2	n2 (1/min)					
Nm	1500	1000	500	250	100	50
< 140	700	870	1150	1370	1700	2000
> 140	590	730	960	1140	1420	1670

Radialkräfte / Radial Forces (N)

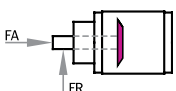

T2	n2 (1/min)					
Nm	1500	1000	500	250	100	50
< 220	1200	1600	1900	2200	2850	3300
> 220	1000	1340	1590	1840	2380	2750

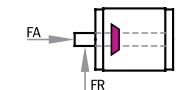

T1	n1 (1/min)					
Nm	3000	1000	500	250	100	50
< 90	1210	1750	2020	2230	3010	3540
> 90	1010	1460	1680	1860	2500	2950

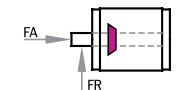

T1	n1 (1/min)					
Nm	3000	1000	500	250	100	50
< 150	1670	2330	2750	3330	4170	5420
< 150	1390	1940	2290	2780	3470	4510

Weitere Erläuterungen und verstärkte Lagerungen siehe Allgemeines
 For more information and reinforced bearings, refer to general information.

Axialkräfte FA = 50% der Radialkräfte - siehe Allgemeines
 Axial forces FA = 50% of radial forces - refer to general information.

Massenträgheitsmomente Moments of Inertia J(kgcm²)
Getriebegewichte Gearbox Weights (kg)

Bauart Model	Übersetzung / Ratio		Bauart Model	ca. Gewicht app. Weight
	1,5:1	2:1		
B0, C0	8,0202	4,8667	B0, C0	18,5
D0	8,1210	4,9675	D0	18,8
			G0, H0	22,7
			J0	23

reduziert auf die Antriebswelle (n1)
 reduced to the input shaft (n1)

Massenträgheitsmomente Moments of Inertia J(kgcm²)
Getriebegewichte Gearbox Weights (kg)

Bauart Model	Übersetzung / Ratio		Bauart Model	ca. Gewicht app. Weight
	1,5:1	2:1		
B0, C0	15,4728	8,8348	B0, C0	27
D0	15,6986	9,0606	D0	27,4
			G0, H0	33,5
			J0	33,9

reduziert auf die Antriebswelle (n1)
 reduced to the input shaft (n1)

Befestigungsseite / Mounting Side

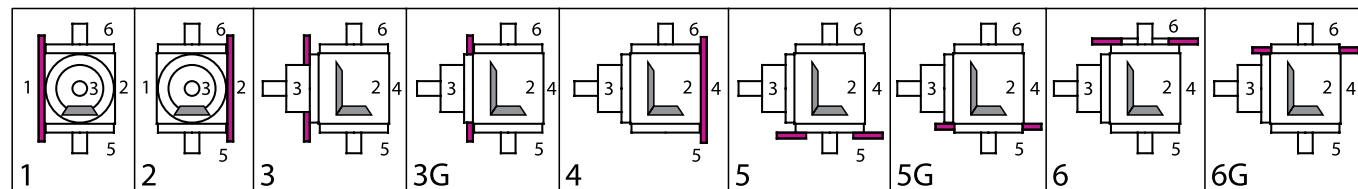

Einbaulagen (unten liegende Getriebeseite) / Mounting Configuration (downward-facing side)

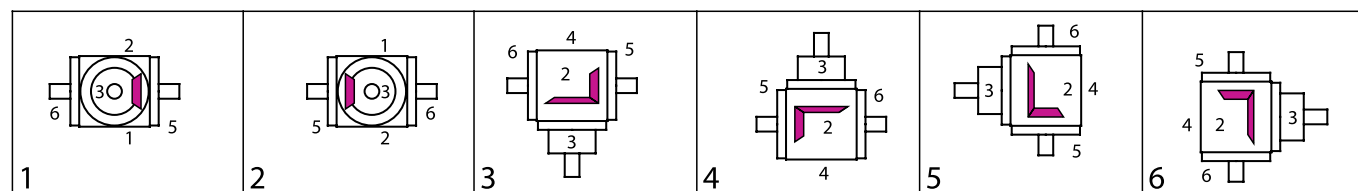

Bestellbeispiel / Example of Order

I Typ Type	Größe Size	IV Übersetzung Ratio	III Bauart Model	V Befestigungs- Mounting Side	VI Einbaulage Mounting Config.	IV Drehzahl Speed	n2max n2max	Ausführung Design
VS	140	2:1	D0	1	1	-	500	0000=Standard

Kegelradgetriebe Typ V
 Bevel Gearboxes Type V

Typ VS 200

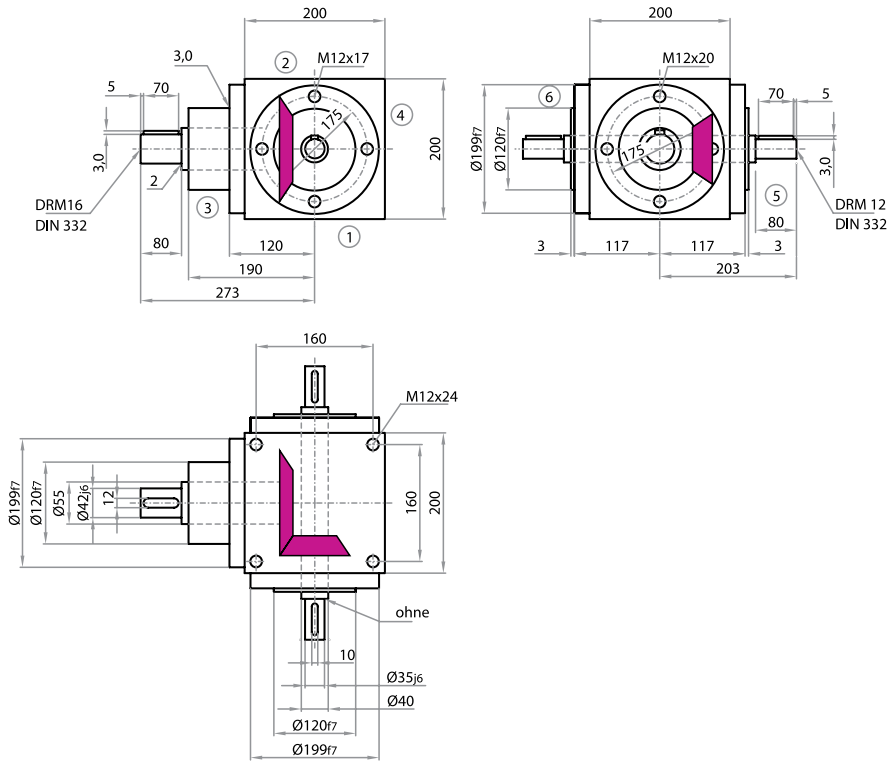

Achtung: Standardbefestigungsgewinde im Gehäuse nur an den Seiten 1, 2 & 4. Alternativ auch an den Seiten 5 & 6 möglich.
Note: Standard fastening thread in the housing only on sides 1, 2 & 4. Alternatively, also possible on sides 5 & 6.

Bauart / Model

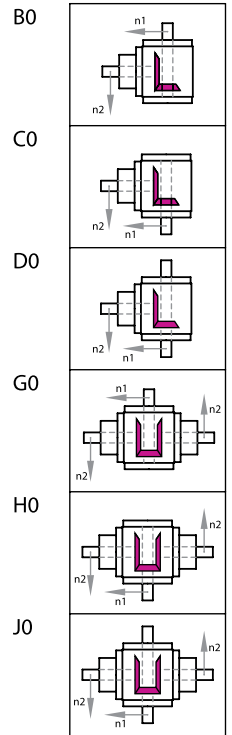

Typ VS 260

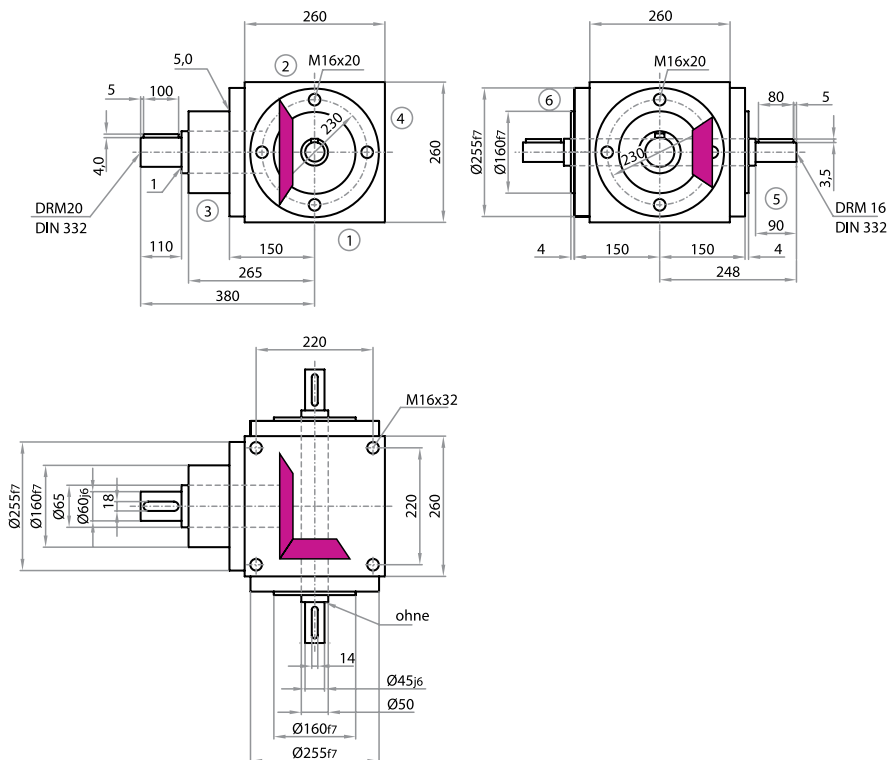

Achtung: Standardbefestigungsgewinde im Gehäuse nur an den Seiten 1, 2 & 4. Alternativ auch an den Seiten 5 & 6 möglich.
Note: Standard fastening thread in the housing only on sides 1, 2 & 4. Alternatively, also possible on sides 5 & 6.

III

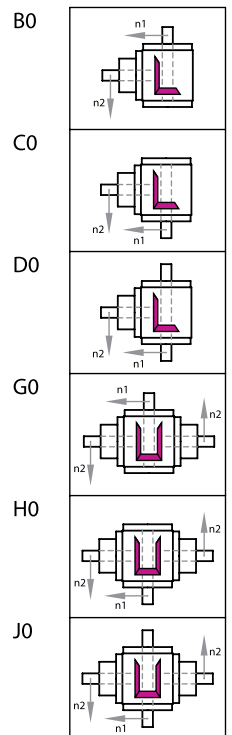

IV Leistungen, Drehmomente / Power Ratings, Torque Ratings [n = min-1, P = kW, T = Nm]
VS 200 VS 260

i = n1	1,5:1 n2	P1N T2N	2:1 n2	P1N T2N
3000	2000	72,75 330	1500	51,25 310,00
2400	1600	63,49 360	1200	45,24 342,00
1500	1000	48,17 437	750	35,13 425,00
1000	667	37,13 505	500	27,56 500,00
750	500	30,31 550	375	21,90 530,00
500	333	22,02 600	250	14,60 530,00
250	167	11,04 600	125	7,30 530,00
50	33	2,18 600	25	1,46 530,00
P1Nt		26,00		26,00
T2max		600,00		530,00

i = n1	1,5:1 n2	P1N T2N	2:1 n2	P1N T2N
3000	2000	189,58 860	1500	133,92 810
2400	1600	158,72 900	1200	112,43 850
1500	1000	104,71 950	750	78,53 950
1000	667	73,5 1000	500	57,87 1050
750	500	55,11 1000	375	48,36 1170
500	333	36,7 1000	250	33,07 1200
250	167	18,4 1000	125	16,53 1200
50	33	3,64 1000	25	3,31 1200
P1Nt		42,00		42,00
T2max		1000,00		1200,00

Radialkräfte / Radial Forces (N)

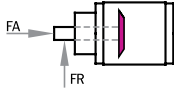

T2 Nm	n2 (1/min)					
	1500	1000	500	250	100	50
< 500	2200	1700	3200	3900	5000	6200
> 500	1840	1420	2670	3250	4170	5170

Radialkräfte / Radial Forces (N)

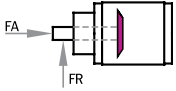

T2 Nm	n2 (1/min)					
	1500	1000	500	250	100	50
< 950	7000	8600				
> 950	5830	7170	9330			

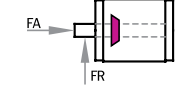

T1 Nm	n1 (1/min)					
	3000	1000	500	250	100	50
< 350	2670	3580	4170	5420	6670	8330
> 350	2220	2990	3470	4510	5560	6940

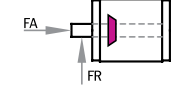

T1 Nm	n1 (1/min)					
	3000	1000	500	250	100	50
< 650	7010					
> 650	5840	9080				

Weitere Erläuterungen und verstärkte Lagerungen siehe Allgemeines
 For more information and reinforced bearings, refer to general information.

Axialkräfte FA = 50% der Radialkräfte - siehe Allgemeines
 Axial forces FA = 50% of radial forces - refer to general information.

Massenträgheitsmomente / Moments of Inertia J(kgcm²) **Getriebegewichte / Gearbox Weights (kg)**

Bauart Model	Übersetzung / Ratio		Bauart Model	ca. Gewicht app. Weight
	1,5:1	2:1		
B0, C0	48,1230	26,6926	B0, C0	18,5
D0	49,2795	27,8491	D0	18,8
			G0, H0	22,7
			J0	23

reduziert auf die Antriebswelle (n1)
 reduced to the input shaft (n1)

Massenträgheitsmomente / Moments of Inertia J(kgcm²) **Getriebegewichte / Gearbox Weights (kg)**

Bauart Model	Übersetzung / Ratio		Bauart Model	ca. Gewicht app. Weight
	1,5:1	2:1		
B0, C0	281,9693	137,4610	B0, C0	83
D0	286,8342	142,3258	D0	84,5
			G0, H0	107
			J0	108,5

reduziert auf die Antriebswelle (n1)
 reduced to the input shaft (n1)

V Befestigungsseite / Mounting Side

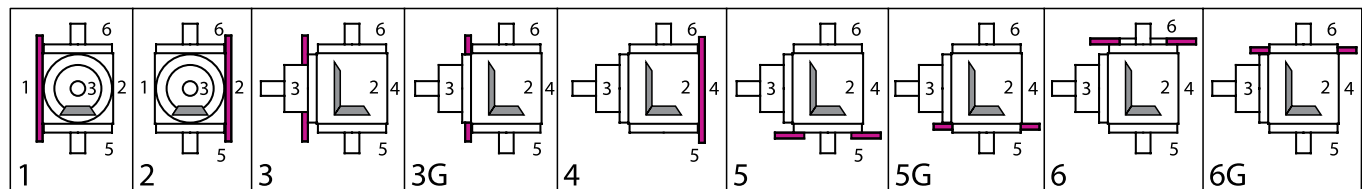

VI Einbautagen (unten liegende Getriebeseite) / Mounting Configuration (downward-facing side)

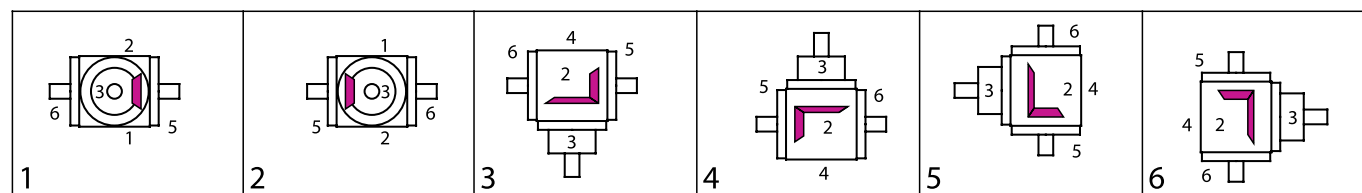

Bestellbeispiel / Example of Order

I Typ Type	Größe Size	IV Übersetzung Ratio	III Bauart Model	V Befestigungs- Mounting Side	VI Einbautage Mounting Config.	IV Drehzahl Speed	n2max n2max	Ausführung Design	300 / 0000=Standard
VS	200	2:1	D0	1	.	1			

Kegelradgetriebe Typ V
 Bevel Gearboxes Type V

Typ VL 065

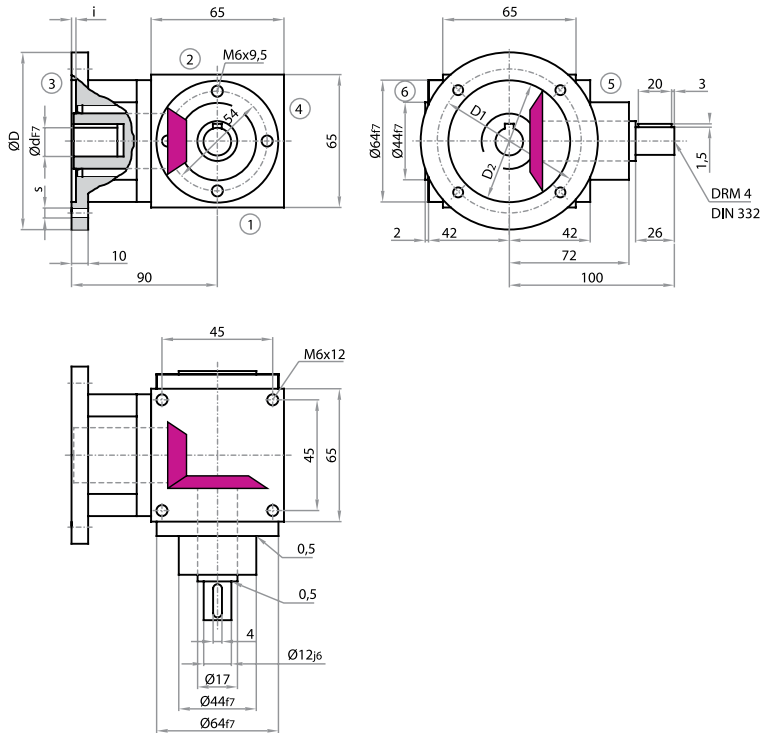

Achtung: Standardbefestigungsgewinde im Gehäuse nur an den Seiten 1, 2 & 4.
 Alternativ auch an den Seiten 5 & 6 im Rastermaß 54x54 möglich.
Note: Standard fastening thread in the housing only on sides 1, 2 & 4.
 Alternatively, also possible in the grid dimension of 54x54 on sides 5 & 6.

Bauart / Model

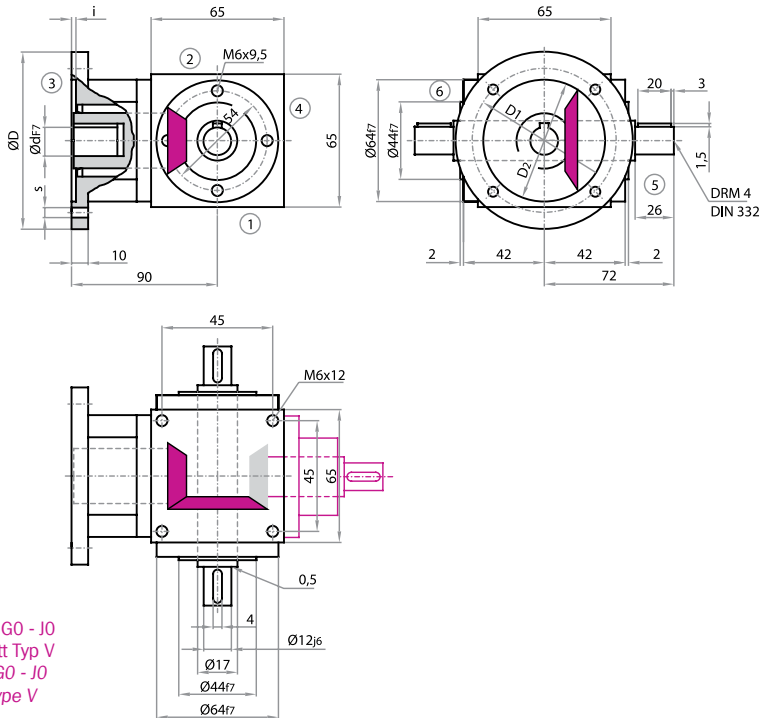
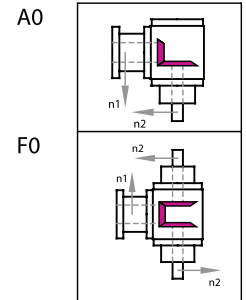

Zusatzflansch für Bauart G0 - J0
 Abmessungen siehe Maßblatt Typ V
 Additional flange for model G0 - J0
 For measurements refer to type V

Achtung: Standardbefestigungsgewinde im Gehäuse nur an den Seiten 1, 2 & 4.
 Alternativ auch an den Seiten 5 & 6 im Rastermaß 54x54 möglich.
Note: Standard fastening thread in the housing only on sides 1, 2 & 4.
 Alternatively, also possible in the grid dimension of 54x54 on sides 5 & 6.

B0

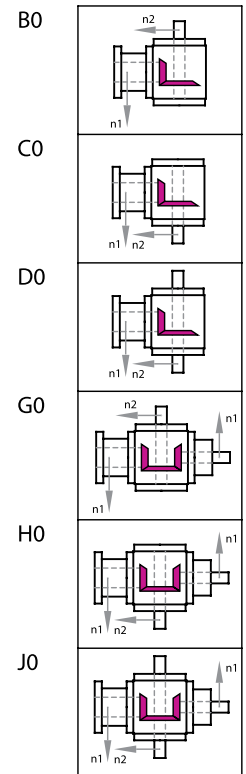

Abmessungen / Measurements

Flanschabmessungen / flange measurements				
D	D1	D2	s	i
105	85	70	7	3
120	100	80	7	3
140	115	95	9	3

passend für Motoranbau / fitted for motor attachment			
Baugröße / Size	D	Bauform / Design	Welle / shaft d
063	120 / 140	B 14 / B 5	11 x 23
071	105 / 140	B 14 / B 14	14 x 30

IV Leistungen, Drehmomente / Power Ratings, Torque Ratings

[n = min-1, P = kW, T = Nm]

i = n1	1:1 n2	P1N T2N	1,5:1 n2	P1N T2N	2:1 n2	P1N T2N	3:1 n2	P1N T2N
3000	3000	3,31 10,00	2000	2,20 10,00	1500	1,65 10,00	1000	1,10 10,00
2400	2400	2,65 10,00	1600	1,76 10,00	1200	1,32 10,00	800	0,88 10,00
1500	1500	1,82 11,00	1000	1,21 11,00	750	0,91 11,00	500	0,61 11,00
1000	1000	1,32 12,00	667	0,88 12,00	500	0,66 12,00	333	0,44 12,00
750	750	1,07 13,00	500	0,72 13,00	375	0,54 13,00	250	0,33 12,00
500	500	0,83 15,00	333	0,55 15,00	250	0,41 15,00	167	0,24 13,00
250	250	0,47 17,00	167	0,31 17,00	125	0,23 17,00	83	0,12 13,00
50	50	0,10 18,00	33	0,07 18,00	25	0,05 18,00	17	0,03 14,00
P1Nt		1,60		1,60		1,60		1,60
T2max		25,00		25,00		25,00		23,00

Radialkräfte / Radial Forces (N)

T2 Nm	n2 (1/min)						T2 Nm	n2 (1/min)					
	3000	1000	500	250	100	50		3000	1000	500	250	100	50
< 12	180	250	300	350	450	550		300	400	500	650	750	900
> 12	150	210	250	290	380	460		250	330	420	540	630	750

Weitere Erläuterungen und verstärkte Lagerungen siehe Allgemeines / For more information and reinforced bearings, refer to general information.
 Axialkräfte FA = 50% der Radialkräfte - siehe Allgemeines / Axial forces FA = 50% of radial forces - refer to general information.

Massenträgheitsmomente / Moments of Inertia J (kgcm²)

reduziert auf die Antriebswelle (n1) / reduced to the input shaft (n1)

Bauart Model	Übersetzung / Transmission Ratios			
	1:1	1,5:1	2:1	3:1
A0	0,6206	0,4859	0,4363	0,3767
F0	0,8150	0,5723	0,4849	0,3983
B0, C0	0,6549	0,5564	0,4854	0,3732
D0	0,6648	0,5608	0,4879	0,3743
G0, H0	0,8493	0,7106	0,6207	0,4552
J0	0,8592	0,7150	0,6232	0,4563

Getriebegehewichte

Gearbox Weights (kg)

Bauart Model	ca. Gewicht app. Weight
A0	3,3
F0	3,7
B0, C0	3,2
D0	3,3
G0, H0	3,6
J0	3,7

Abzug für Motorwellenbohrung / Reduction for motor shaft bore

Ø d x l	09x20 = -0,0013	11x23 = -0,0032	14x30 = -0,0107
---------	-----------------	-----------------	-----------------

V Befestigungsseite / Mounting Side

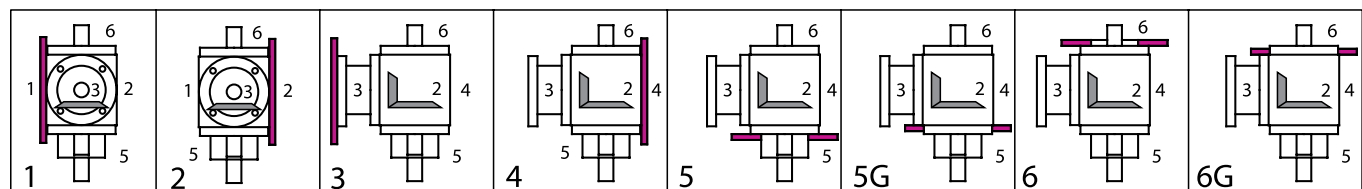

VI Einbautagen (unten liegende Getriebeseite) / Mounting Configuration (downward-facing side)

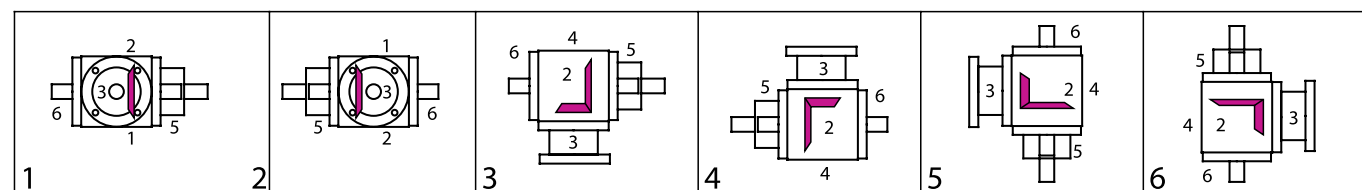

Bestellbeispiel / Example of Order

I Typ Type	Größe Size	IV Übersetzung Ratio	III Bauart Model	V Befestigungs- Mounting Side	VI Einbautage Mounting Config.	IV Drehzahl n2max Speed n2max	Ausführung Design
VL	065	3:1	A0	1	1	500	0000=Standard
II	Ø Flansch Ø Flange	III	Welle (Ø x Länge) Shaft (Ø x length)				
	D 120		/ 14 x 30				

Kegelradgetriebe Typ V
Bevel Gearboxes Type V

Typ VL 065

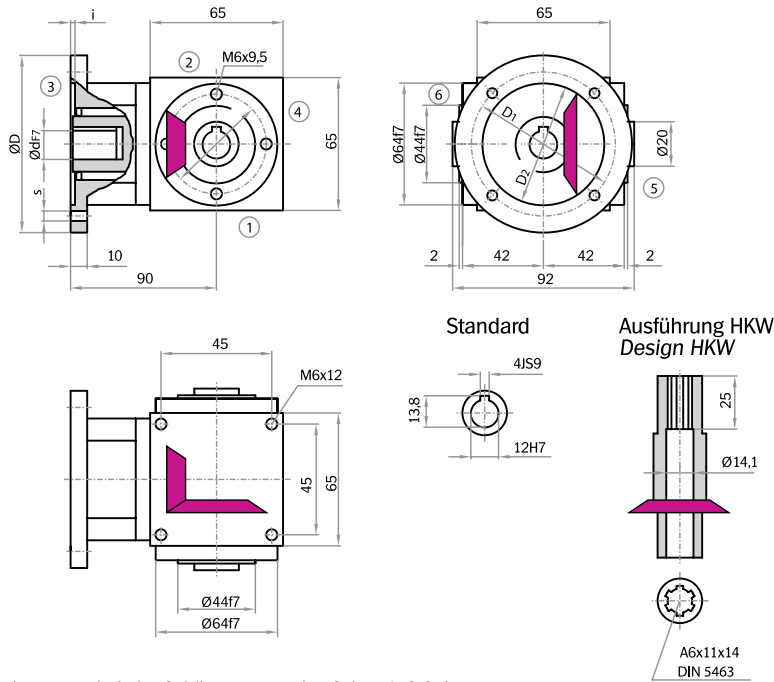

Achtung: Standardbefestigungsgewinde im Gehäuse nur an den Seiten 1, 2 & 4.
 Alternativ auch an den Seiten 5 & 6 im Rastermaß 54x54 möglich.
Note: Standard fastening thread in the housing only on sides 1, 2 & 4.
 Alternatively, also possible in the grid dimension of 54x54 on sides 5 & 6.

Bauart / Model

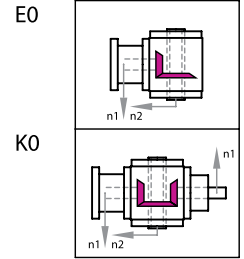

Bauart / Model

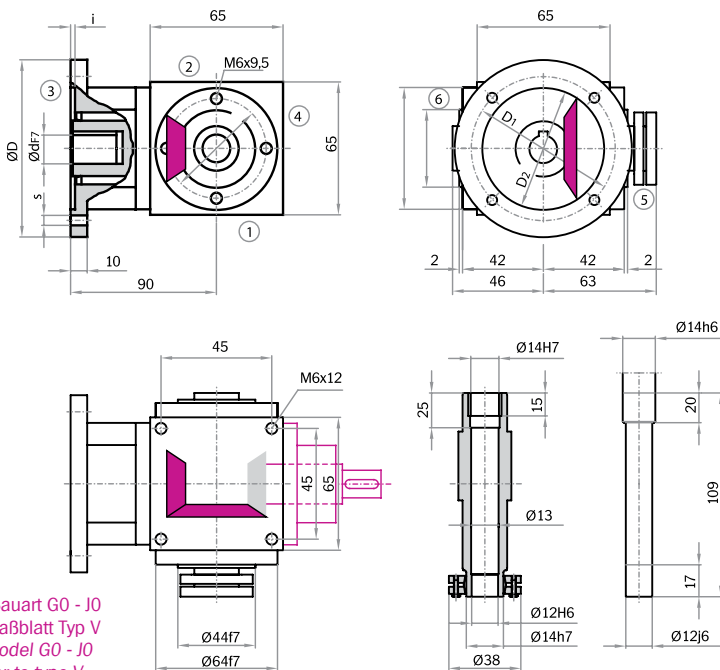

Zusatzhalsflansch für Bauart G0 - J0
 Abmessungen siehe Maßblatt Typ V
 Additional flange for model G0 - J0
 For measurements refer to type V

Achtung: Standardbefestigungsgewinde im Gehäuse nur an den Seiten 1, 2 & 4.
 Alternativ auch an den Seiten 5 & 6 im Rastermaß 54x54 möglich.
Note: Standard fastening thread in the housing only on sides 1, 2 & 4.
 Alternatively, also possible in the grid dimension of 54x54 on sides 5 & 6.

Standard

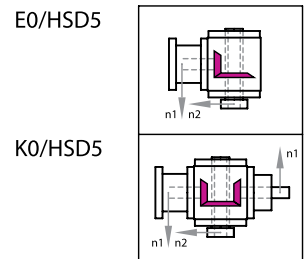

Spezial

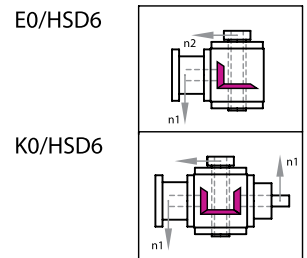

Abmessungen / Measurements

Flanschabmessungen / flange measurements				
D	D1	D2	s	i
105	85	70	7	3
120	100	80	7	3
140	115	95	9	3

passend für Motoranbau / fitted for motor attachment			
Baugröße / Size	D	Bauform / Design	Welle / shaft d
063	120 / 140	B 14 / B 5	11 x 23
071	105 / 140	B 14 / B 14	14 x 30

IV Leistungen, Drehmomente / Power Ratings, Torque Ratings

[n = min-1, P = kW, T = Nm]

i =	1:1	P1N	1,5:1	P1N	2:1	P1N	3:1	P1N
n1	n2	T2N	n2	T2N	n2	T2N	n2	T2N
3000	3000	3,31	2000	2,20	1500	1,65	1000	1,10
		10,00		10,00		10,00		10,00
2400	2400	2,65	1600	1,76	1200	1,32	800	0,88
		10,00		10,00		10,00		10,00
1500	1500	1,82	1000	1,21	750	0,91	500	0,61
		11,00		11,00		11,00		11,00
1000	1000	1,32	667	0,88	500	0,66	333	0,44
		12,00		12,00		12,00		12,00
750	750	1,07	500	0,72	375	0,54	250	0,33
		13,00		13,00		13,00		13,00
500	500	0,83	333	0,55	250	0,41	167	0,24
		15,00		15,00		15,00		13,00
250	250	0,47	167	0,31	125	0,23	83	0,12
		17,00		17,00		17,00		13,00
50	50	0,10	33	0,07	25	0,05	17	0,03
		18,00		18,00		18,00		14,00
P1Nt		1,60		1,60		1,60		1,60
T2max		25,00		25,00		25,00		23,00

Radialkräfte / Radial Forces (N)

T2 Nm	n2 (1/min)						T2 Nm	n2 (1/min)					
	3000	1000	500	250	100	50		3000	1000	500	250	100	50
< 12	180	250	300	350	450	550		300	400	500	650	750	900
> 12	150	210	250	290	380	460		250	330	420	540	630	750

Weitere Erläuterungen und verstärkte Lagerungen siehe Allgemeines / For more information and reinforced bearings, refer to general information.
 Axialkräfte FA = 50% der Radialkräfte - siehe Allgemeines / Axial forces FA = 50% of radial forces - refer to general information.

Massenträgheitsmomente / Moments of Inertia J (kgcm²)

reduziert auf die Antriebswelle (n1) / reduced to the input shaft (n1)

Bauart Model	Übersetzung / Transmission Ratios			
	1:1	1,5:1	2:1	3:1
E0	0,7072	0,6087	0,5377	0,4255
K0	0,9016	0,7629	0,6730	0,5075
E0/HSD	0,8330	0,7345	0,6635	0,5513
K0/HSD	1,0274	0,8887	0,7988	0,6333

Getriebegewichte

Gearbox Weights (kg)

Bauart Model	ca. Gewicht app. Weight
E0	3,1
K0	3,5
E0/HSD	3,1
K0/HSD	3,5

Abzug für Motorwellenbohrung / Reduction for motor shaft bore

Ø d x l	09x20 = -0,0013	11x23 = -0,0032	14x30 = -0,0107
---------	-----------------	-----------------	-----------------

V Befestigungsseite / Mounting Side

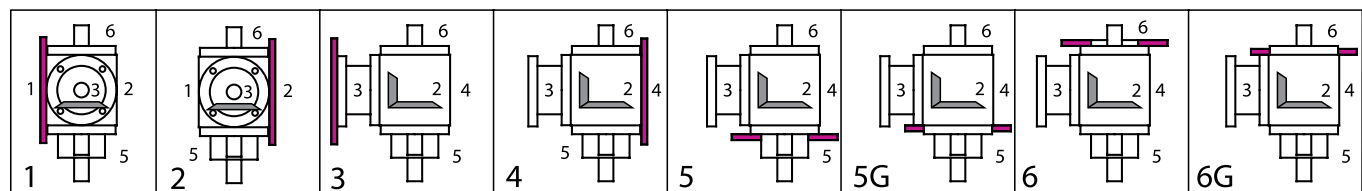

VI Einbautagen (unten liegende Getriebeseite) / Mounting Configuration (downward-facing side)

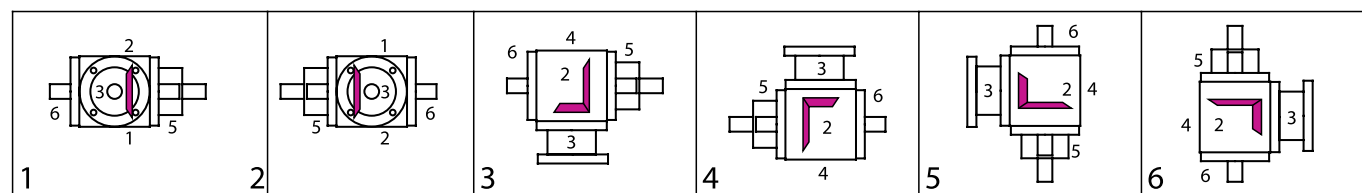

Bestellbeispiel / Example of Order

I Typ Type VL	Größe Size 065	IV Übersetzung Ratio 3:1	III Bauart Model E0	V Befestigungs- Mounting Side 1	VI Einbautage Mounting Config. 1	IV Drehzahl n2max Speed n2max 500 / 0000=Standard	Ausführung Design
II ø Flansch ø Flange D 120	II Welle (ø x Länge) Shaft (ø x length) / 14 x 30						

Kegelradgetriebe Typ V
Bevel Gearboxes Type V

Typ VL 090

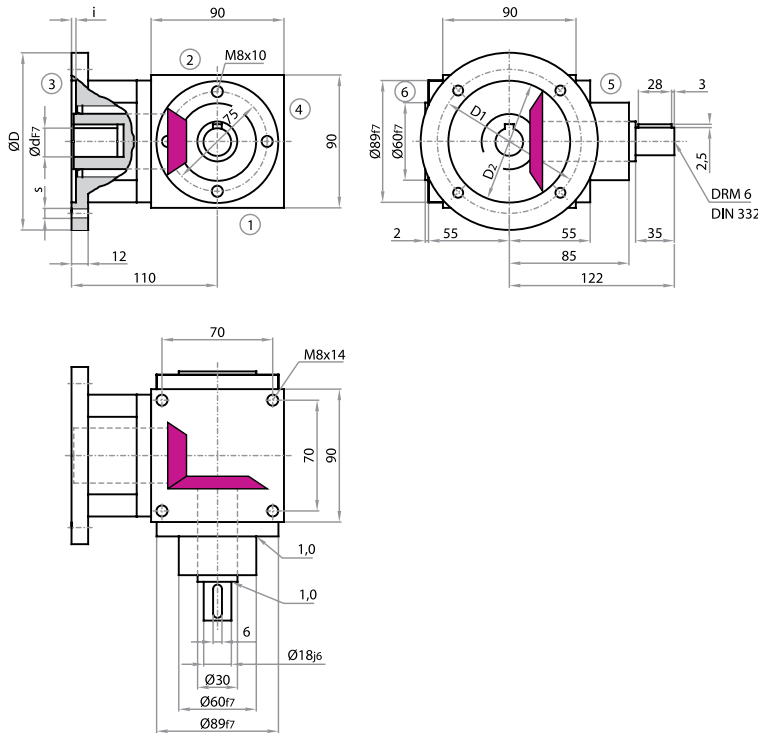

Bauart / Model

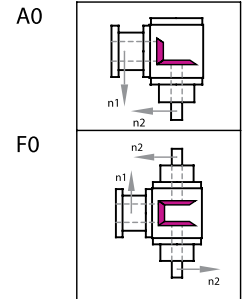

Achtung: Standardbefestigungsgewinde im Gehäuse nur an den Seiten 1, 2 & 4.
 Alternativ auch an den Seiten 5 & 6 im Rastermaß 75x75 möglich.
Note: Standard fastening thread in the housing only on sides 1, 2 & 4.
 Alternatively, also possible in the grid dimension of 75x75 on sides 5 & 6.

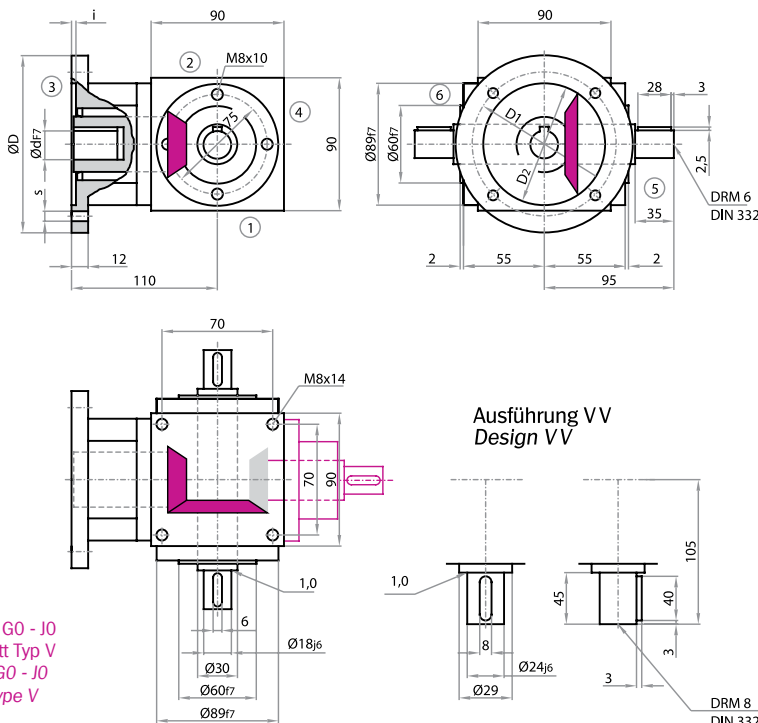

Bauart / Model

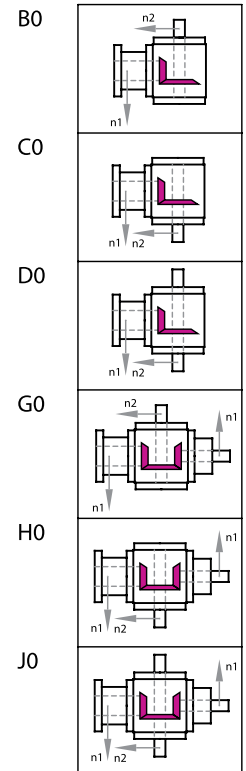

Zusatzflansch für Bauart G0 - J0
 Abmessungen siehe Maßblatt Typ V
 Additional flange for model G0 - J0
 For measurements refer to type V

Achtung: Standardbefestigungsgewinde im Gehäuse nur an den Seiten 1, 2 & 4.
 Alternativ auch an den Seiten 5 & 6 im Rastermaß 75x75 möglich.
Note: Standard fastening thread in the housing only on sides 1, 2 & 4.
 Alternatively, also possible in the grid dimension of 75x75 on sides 5 & 6.

Abmessungen / Measurements

Flanschabmessungen / flange measurements				
D	D1	D2	s	i
120	100	80	7	3
140	115	95	9	3
160	130	110	9	4

passend für Motoranbau / fitted for motor attachment			
Baugröße / Size	D	Bauform / Design	Welle / shaft d
063	120 / 140	B 14 / B 5	11 x 23
071	140 / 160	B 14 / B 5	14 x 30
080	120 / 160	B 14 / B 14	19 x 40

V Leistungen, Drehmomente / Power Ratings, Torque Ratings

[n=min-1, P=KW, T=Nm]

i =	1:1	P1N	1,5:1	P1N	2:1	P1N	3:1	P1N	4:1	P1N	5:1	P1N	6:1	P1N
n1	n2	T2N	n2	T2N	n2	T2N	n2	T2N	n2	T2N	n2	T2N	n2	T2N
3000	3000	8,93	2000	5,51	1500	3,80	1000	2,54	750	1,90	600	1,52	500	1,25
		27,00		25,00		23,00		23,00		23,00		23,00		23,00
2400	2400	7,41	1600	4,59	1200	3,17	800	2,12	600	1,65	480	1,32	400	1,09
		28,00		26,00		24,00		24,00		25,00		25,00		25,00
1500	1500	5,29	1000	3,20	750	2,23	500	1,49	375	1,12	300	0,89	250	0,74
		32,00		29,00		27,00		27,00		27,00		27,00		27,00
1000	1000	3,75	667	2,35	500	1,71	333	1,14	250	0,85	200	0,68	167	0,53
		34,00		32,00		31,00		31,00		31,00		31,00		29,00
750	750	3,06	500	1,93	375	1,32	250	0,88	187,5	0,66	150	0,53	125	0,40
		37,00		35,00		32,00		32,00		32,00		32,00		29,00
500	500	2,20	333	1,36	250	0,94	167	0,63	125	0,47	100	0,37	83	0,27
		40,00		37,00		34,00		34,00		34,00		34,00		29,00
250	250	1,21	167	0,74	125	0,50	83	0,33	62,5	0,25	50	0,20	42	0,14
		44,00		40,00		36,00		36,00		36,00		36,00		30,00
50	50	0,28	33	0,15	25	0,10	17	0,07	12,5	0,05	10	0,04	8,3	0,03
		50,00		40,00		37,00		37,00		37,00		37,00		33,00
P1Nt		3,80		3,80		3,80		3,80		3,80		3,80		3,80
T2max		105,00		40,00		80,00		70,00		70,00		60,00		50,00

Radialkräfte / Radial Forces (N)

T2 Nm	n2 (1/min)						T2 Nm	n2 (1/min)					
	3000	1000	500	250	100	50		3000	1000	500	250	100	50
< 30	300	400	470	580	700	800	> 30	500	660	800	950	1250	1500
> 30	250	330	390	490	590	670		420	550	670	790	1040	1250

Weitere Erläuterungen und verstärkte Lagerungen siehe Allgemeines / For more information and reinforced bearings, refer to general information.
 Axialkräfte FA = 50% der Radialkräfte - siehe Allgemeines / Axial forces FA = 50% of radial forces - refer to general information.

Massenträgheitsmomente / Moments of Inertia J (kgcm²)

reduziert auf die Antriebswelle (n1) / reduced to the input shaft (n1)

Bauart Model	Übersetzung / Transmission Ratios						
	1:1	1,5:1	2:1	3:1	4:1	5:1	6:1
A0	2,8840	1,8274	1,4820	1,2212	1,1505	1,0992	1,0933
F0	4,1635	2,3960	1,8019	1,3633	1,2304	1,1504	1,1289
B0, C0	3,6793	2,5285	1,7035	1,3793	1,2481	1,1677	1,1373
D0	3,7077	2,5411	1,7106	1,3824	1,2499	1,1689	1,1381
G0, H0	4,9588	3,4420	2,5273	2,1255	1,5312	1,4413	1,4080
J0	4,9872	3,4546	2,5344	2,1286	1,5330	1,4425	1,4088

Abzug für Motorwellenbohrung / Reduction for motor shaft bore

Ø d x l	11x23 = -0,0032	14x30 = -0,0107	19x40 = -0,0502
---------	-----------------	-----------------	-----------------

Getriebegewichte

Gearbox Weights (kg)

Bauart Model	ca. Gewicht app. Weight
A0	6,7
F0	7,9
B0, C0	7
D0	7,1
G0, H0	8,5
J0	8,6

V Befestigungsseite / Mounting Side

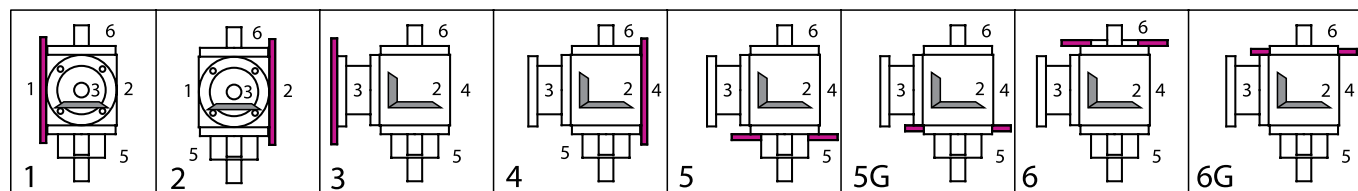

V Einbautagen (unten liegende Getriebeseite) / Mounting Configuration (downward-facing side)

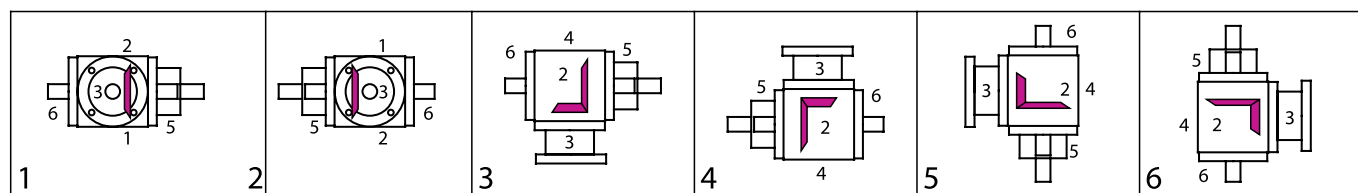

Bestellbeispiel / Example of Order

I Typ Type VL	Größe Size 090	IV Übersetzung Ratio 3:1	III Bauart Model A0	V Befestigungs- Mounting Side 1	VI Einbaulage Mounting Config. 1	IV Drehzahl n2max Speed n2max 500	Ausführung Design 0000=Standard
II Ø Flansch Ø Flange D 140	II Welle (Ø x Länge) Shaft (Ø x length) / 14 x 30						

Kegelradgetriebe Typ V
Bevel Gearboxes Type V

Typ VL 090

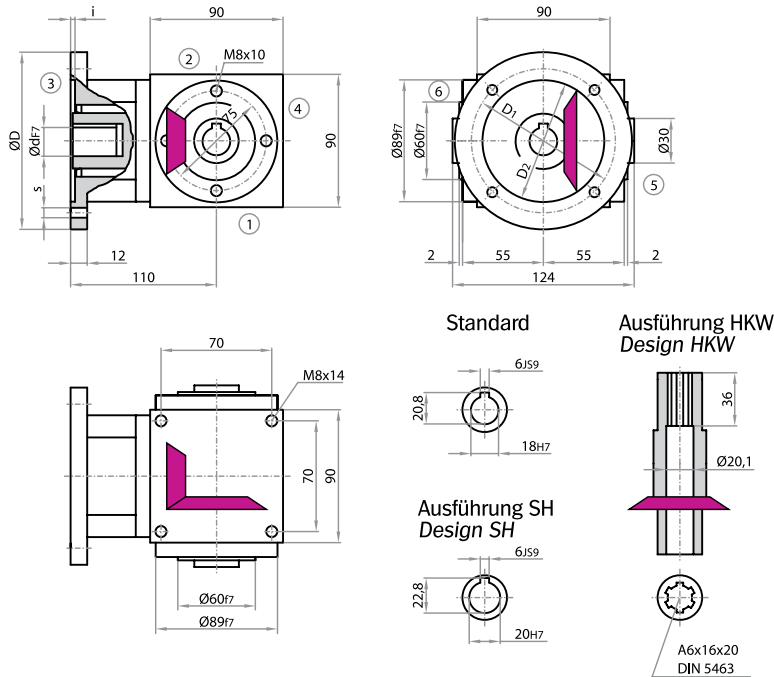

Achtung: Standardbefestigungsgewinde im Gehäuse nur an den Seiten 1, 2 & 4.
 Alternativ auch an den Seiten 5 & 6 im Rastermaß 75x75 möglich.
Note: Standard fastening thread in the housing only on sides 1, 2 & 4.
 Alternatively, also possible in the grid dimension of 75x75 on sides 5 & 6.

Bauart / Model

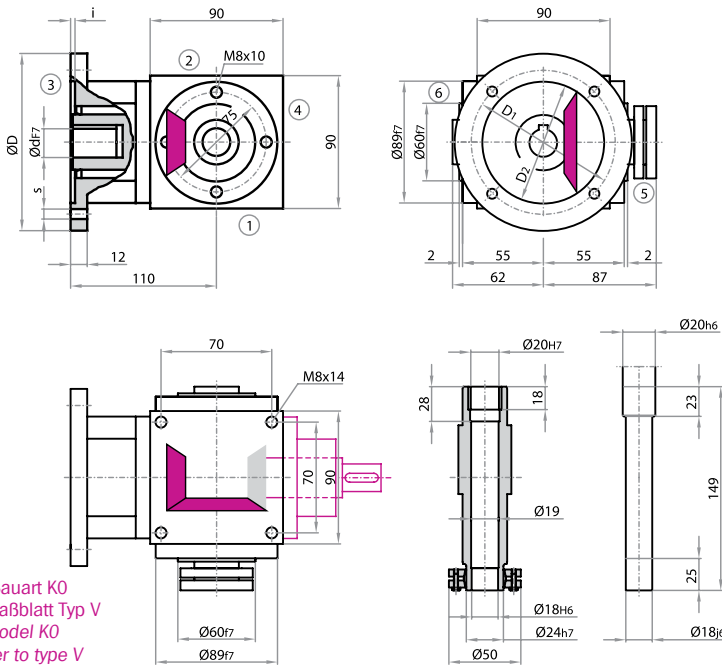
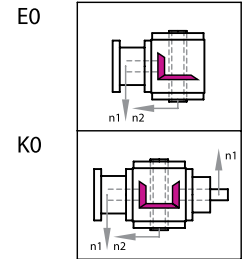

Zusatzflansch für Bauart K0
 Abmessungen siehe Maßblatt Typ V
 Additional flange for model K0
 For measurements refer to type V

Achtung: Standardbefestigungsgewinde im Gehäuse nur an den Seiten 1, 2 & 4.
 Alternativ auch an den Seiten 5 & 6 im Rastermaß 75x75 möglich.
Note: Standard fastening thread in the housing only on sides 1, 2 & 4.
 Alternatively, also possible in the grid dimension of 75x75 on sides 5 & 6.

Bauart / Model

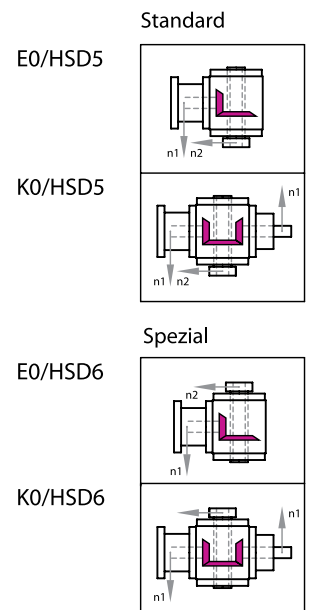

Abmessungen / Measurements

Flanschabmessungen / flange measurements				
D	D1	D2	s	i
120	100	80	7	3
140	115	95	9	3
160	130	110	9	4

passend für Motoranbau / fitted for motor attachment			
Baugröße / Size	D	Bauform / Design	Welle / shaft d
063	120 / 140	B 14 / B 5	11 x 23
071	140 / 160	B 14 / B 5	14 x 30
080	120 / 160	B 14 / B 14	19 x 40

IV Leistungen, Drehmomente / Power Ratings, Torque Ratings

[n=min-1, P=kW, T=Nm]

i = n1	1:1 n2	P1N T2N	1,5:1 n2	P1N T2N	2:1 n2	P1N T2N	3:1 n2	P1N T2N	4:1 n2	P1N T2N	5:1 n2	P1N T2N	6:1 n2	P1N T2N
3000	3000	8,93 27,00	2000	5,51 25,00	1500	3,80 23,00	1000	2,54 23,00	750	1,90 23,00	600	1,52 23,00	500	1,25 23,00
2400	2400	7,41 28,00	1600	4,59 26,00	1200	3,17 24,00	800	2,12 24,00	600	1,65 25,00	480	1,32 25,00	400	1,09 25,00
1500	1500	5,29 32,00	1000	3,20 29,00	750	2,23 27,00	500	1,49 27,00	375	1,12 27,00	300	0,89 27,00	250	0,74 27,00
1000	1000	3,75 34,00	667	2,35 32,00	500	1,71 31,00	333	1,14 31,00	250	0,85 31,00	200	0,68 31,00	167	0,53 29,00
750	750	3,06 37,00	500	1,93 35,00	375	1,32 32,00	250	0,88 32,00	187,5	0,66 32,00	150	0,53 32,00	125	0,40 29,00
500	500	2,20 40,00	333	1,36 37,00	250	0,94 34,00	167	0,63 34,00	125	0,47 34,00	100	0,37 34,00	83	0,27 29,00
250	250	1,21 44,00	167	0,74 40,00	125	0,50 36,00	83	0,33 36,00	62,5	0,25 36,00	50	0,20 36,00	42	0,14 30,00
50	50	0,28 50,00	33	0,15 40,00	25	0,10 37,00	17	0,07 37,00	12,5	0,05 37,00	10	0,04 37,00	8,3	0,03 33,00
P1Nt		3,80		3,80		3,80		3,80		3,80		3,80		3,80
T2max		105,00		40,00		80,00		70,00		70,00		60,00		50,00

Radialkräfte / Radial Forces (N)

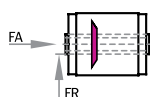

T2 Nm	n2 (1/min)					
	3000	1000	500	250	100	50
< 30	500	660	800	950	1250	1500
> 30	420	550	670	790	1040	1250

Weitere Erläuterungen und verstärkte Lagerungen siehe Allgemeines / For more information and reinforced bearings, refer to general information.
 Axialkräfte FA = 50% der Radialkräfte - siehe Allgemeines / Axial forces FA = 50% of radial forces - refer to general information.

Massenträgheitsmomente / Moments of Inertia J (kgcm²)

reduziert auf die Antriebswelle (n1) / reduced to the input shaft (n1)

Bauart Model	Übersetzung / Transmission Ratios						
	1:1	1,5:1	2:1	3:1	4:1	5:1	6:1
E0	3,5757	2,4824	1,6776	1,3678	1,2416	1,1636	1,1344
K0	4,8552	3,3959	2,5014	2,1140	1,5247	1,4372	1,4051
E0/HSD	4,2463	2,7805	1,8452	1,4423	1,2835	1,1904	1,1531
K0/HSD	5,5258	3,6940	2,6690	2,1885	1,5666	1,4611	1,4238

Getriebegewichte

Gearbox Weights (kg)

Bauart Model	ca. Gewicht app. Weight
E0	6,6
K0	8,1
E0/HSD	6,8
K0/HSD	8,3

Abzug für Motorwellenbohrung / Reduction for motor shaft bore

Ø d x l	11x23 = -0,0032	14x30 = -0,0107	19x40 = -0,0502
---------	-----------------	-----------------	-----------------

V Befestigungsseite / Mounting Side

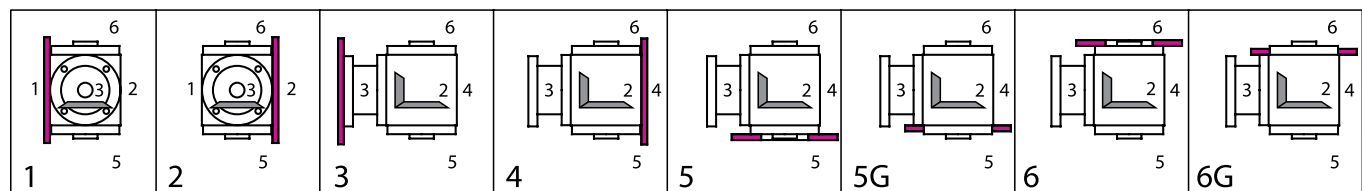

VI Einbautagen (unten liegende Getriebeseite) / Mounting Configuration (downward-facing side)

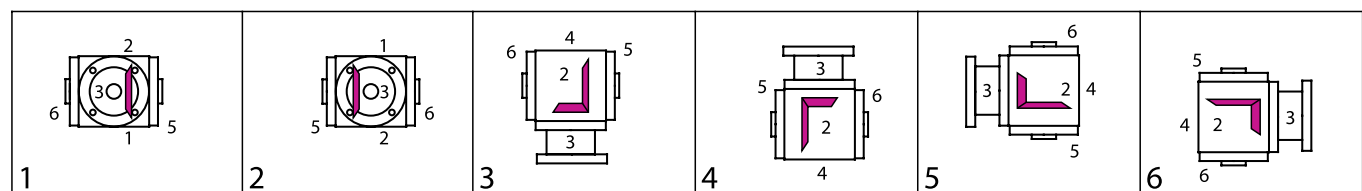

Bestellbeispiel / Example of Order

I Typ Type	Größe Size	IV Übersetzung Ratio	III Bauart Model	V Befestigungs- Mounting Side	VI Einbautage Mounting Config.	IV Drehzahl n2max Speed n2max	Ausführung Design
VL	090	3:1	E0	1	1	500 / 0000=Standard	
II ø Flansch ø Flange	II Welle (ø x Länge) Shaft (ø x length)						
D 140	/ 14 x 30						

Kegelradgetriebe Typ V
Bevel Gearboxes Type V

Typ VL 120

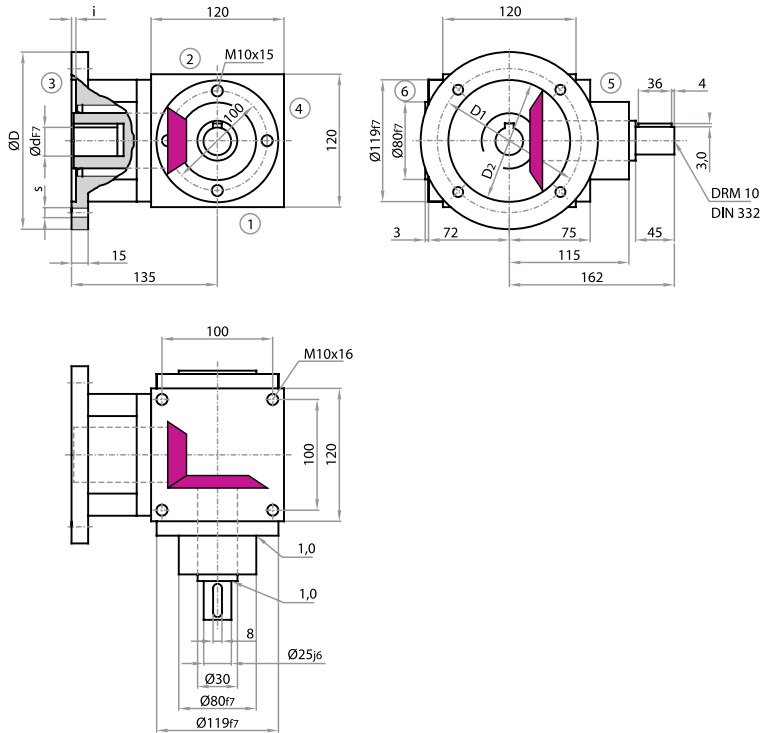

Bauart / Model

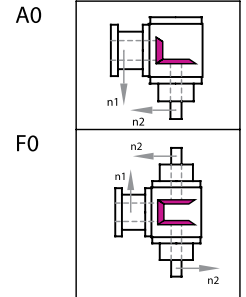

Achtung: Standardbefestigungsgewinde im Gehäuse nur an den Seiten 1, 2 & 4. Alternativ auch an den Seiten 5 & 6 möglich.
Note: Standard fastening thread in the housing only on sides 1, 2 & 4. Alternatively, also possible on sides 5 & 6.

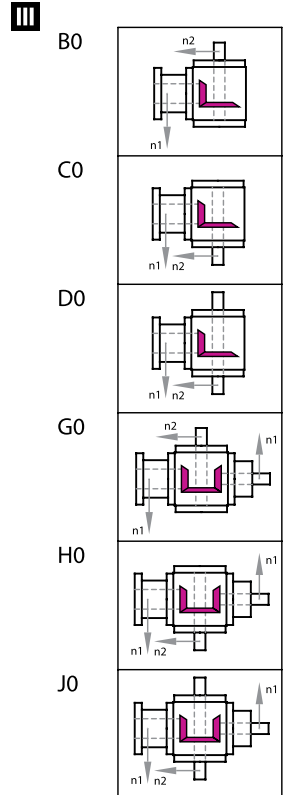
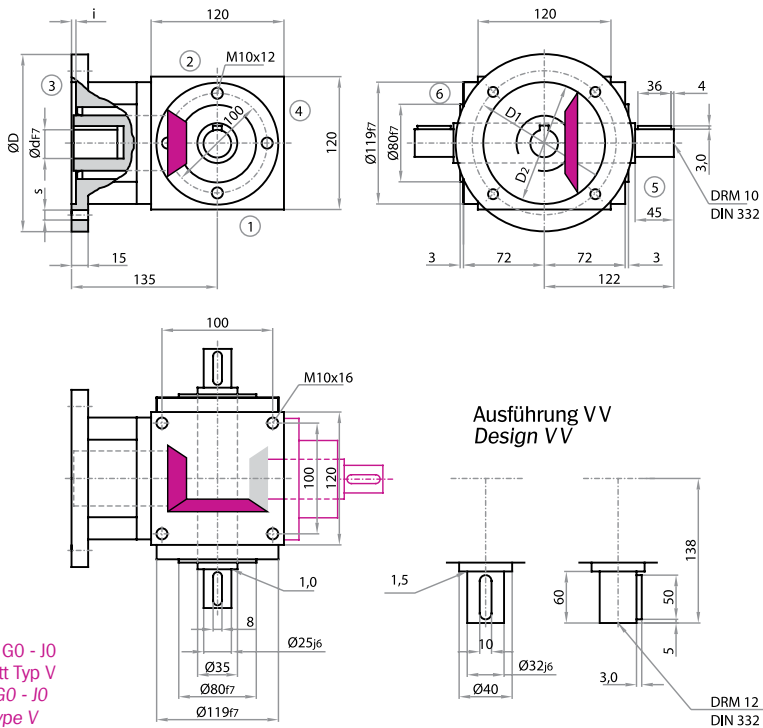

Zusatzflansch für Bauart G0 - J0
 Abmessungen siehe Maßblatt Typ V
 Additional flange for model G0 - J0
 For measurements refer to type V

Achtung: Standardbefestigungsgewinde im Gehäuse nur an den Seiten 1, 2 & 4. Alternativ auch an den Seiten 5 & 6 möglich.
Note: Standard fastening thread in the housing only on sides 1, 2 & 4. Alternatively, also possible on sides 5 & 6.

Abmessungen / Measurements

Flanschabmessungen / flange measurements				
D	D1	D2	s	i
140	115	95	9	3
160	130	110	9	4
200	165	130	11	4
250	215	180	14	5

passend für Motoranbau / fitted for motor attachment			
Baugröße / Size	D	Bauform / Design	Welle / shaft d
080	160 / 200	B 14 / B 5	19 x 40
090	160 / 200	B 14 / B 5	24 x 50
100	200 / 250	B 14 / B 5	28 x 60
112	200 / 250	B 14 / B 5	28 x 60

IV Leistungen, Drehmomente / Power Ratings, Torque Ratings

[n = min-1, P = kW, T = Nm]

i =	1:1	P1N	1,5:1	P1N	2:1	P1N	3:1	P1N	4:1	P1N	5:1	P1N	6:1	P1N
n1	n2	T2N	n2	T2N	n2	T2N	n2	T2N	n2	T2N	n2	T2N	n2	T2N
3000	3000	21,82	2000	13,45	1500	9,26	1000	6,39	750	4,96	600	3,97	500	2,95
		66,00		61,00		56,00		58,00		60,00		60,00		54,00
2400	2400	18,52	1600	11,46	1200	8,07	800	5,56	600	4,43	480	3,44	400	2,53
		70,00		65,00		61,00		63,00		67,00		65,00		57,00
1500	1500	13,56	1000	8,60	750	6,03	500	4,08	375	3,06	300	2,38	250	1,75
		82,00		78,00		73,00		74,00		74,00		72,00		64,00
1000	1000	10,14	667	6,32	500	4,40	333	3,01	250	2,18	200	1,76	167	1,22
		92,00		86,00		80,00		82,00		79,00		80,00		66,00
750	750	8,51	500	5,18	375	3,30	250	2,40	187,5	1,69	150	1,42	125	0,94
		103,00		94,00		80,00		87,00		82,00		86,00		68,00
500	500	6,34	333	3,70	250	2,20	167	1,66	125	1,16	100	0,98	83	0,63
		115,00		100,00		80,00		90,00		84,00		89,00		69,00
250	250	3,39	167	1,84	125	1,10	83	0,87	62,5	0,60	50	0,51	42	0,33
		123,00		100,00		80,00		95,00		87,00		92,00		71,00
50	50	0,72	33	0,37	25	0,22	17	0,21	12,5	0,12	10	0,10	8,3	0,06
		130,00		100,00		80,00		110,00		90,00		95,00		66,00
P1Nt		6,20		6,20		6,20		6,20		6,20		6,20		6,20
T2max		220,00		100,00		80,00		155,00		155,00		140,00		120,00

Radialkräfte / Radial Forces (N)

FA	FR	T2 Nm	n2 (1/min)						FA	FR	n2 (1/min)					
			3000	1000	500	250	100	50			3000	1000	500	250	100	50
<		80	470	620	720	900	1150	1400			750	1000	1250	1500	1900	2200
>		80	390	520	600	750	960	1170			630	830	1040	1250	1580	1830

Weitere Erläuterungen und verstärkte Lagerungen siehe Allgemeines / For more information and reinforced bearings, refer to general information.

Axialkräfte FA = 50% der Radialkräfte - siehe Allgemeines / Axial forces FA = 50% of radial forces - refer to general information.

Massenträgheitsmomente / Moments of Inertia J (kgcm²)

reduziert auf die Antriebswelle (n1) / reduced to the input shaft (n1)

Bauart Model	Übersetzung / Transmission Ratios						
	1:1	1,5:1	2:1	3:1	4:1	5:1	6:1
A0	12,5824	6,9334	5,4003	4,7975	4,4628	4,2966	4,2267
F0	17,8312	9,2662	6,7125	5,3807	4,7908	4,5065	4,3725
B0, C0	17,3870	9,5366	6,7285	5,4939	4,9193	4,6043	4,4483
D0	17,6844	9,6687	6,8028	5,5269	4,9379	4,6162	4,4566
G0, H0	22,6358	12,0447	9,0628	7,2266	5,8076	5,1459	4,9791
J0	22,9332	12,1768	9,1371	7,2596	5,8262	5,1578	4,9874

Abzug für Motorwellenbohrung / Reduction for motor shaft bore

Ø d x l	19x40 = -0,0502	24x50 = -0,1534	28x60 = -0,3126
---------	-----------------	-----------------	-----------------

Getriebegewichte

Gearbox Weights (kg)

Bauart Model	ca. Gewicht app. Weight
A0	15,6
F0	18
B0, C0	15,3
D0	15,5

V Befestigungsseite / Mounting Side

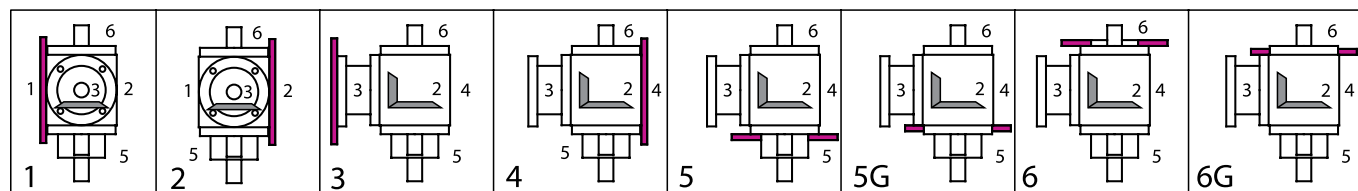

V Einbautagen (unten liegende Getriebeseite) / Mounting Configuration (downward-facing side)

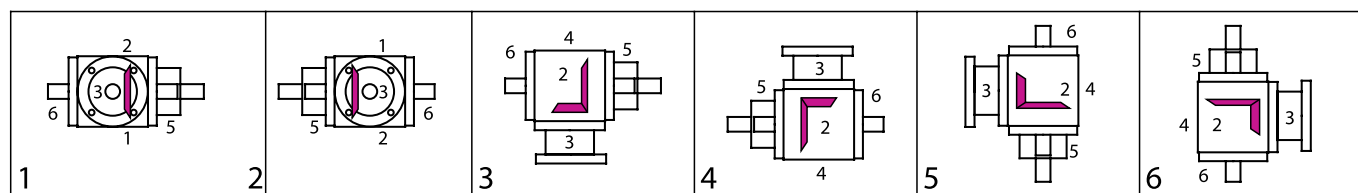

Bestellbeispiel / Example of Order

I	Typ	Größe	IV	Übersetzung	III	Bauart	V	Befestigungs-	VI	Einbaulage	IV	Drehzahl	n2max	Ausführung
	Type	Size		Ratio		Model		Mounting Side		Mounting Config.		Speed	n2max	Design
	VL	120		3:1		A0		1		1		-	500	0000=Standard
II	Ø Flansch Ø Flange D 160		II	Welle (Ø x Länge) Shaft (Ø x length) / 19 x 40										

Kegelradgetriebe Typ V
Bevel Gearboxes Type V

Typ VL 120

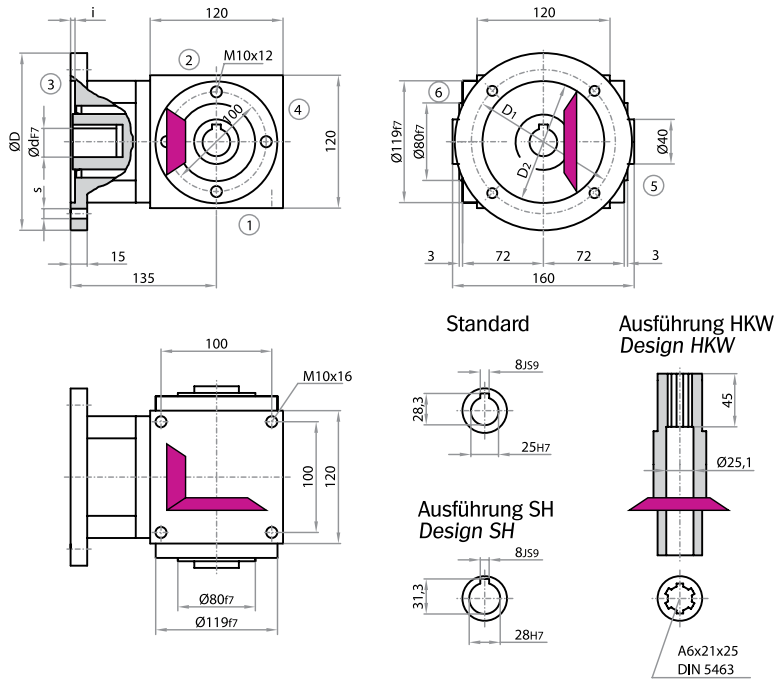

Achtung: Standardbefestigungsgewinde im Gehäuse nur an den Seiten 1, 2 & 4. Alternativ auch an den Seiten 5 & 6 möglich.
Note: Standard fastening thread in the housing only on sides 1, 2 & 4. Alternatively, also possible on sides 5 & 6.

Bauart / Model

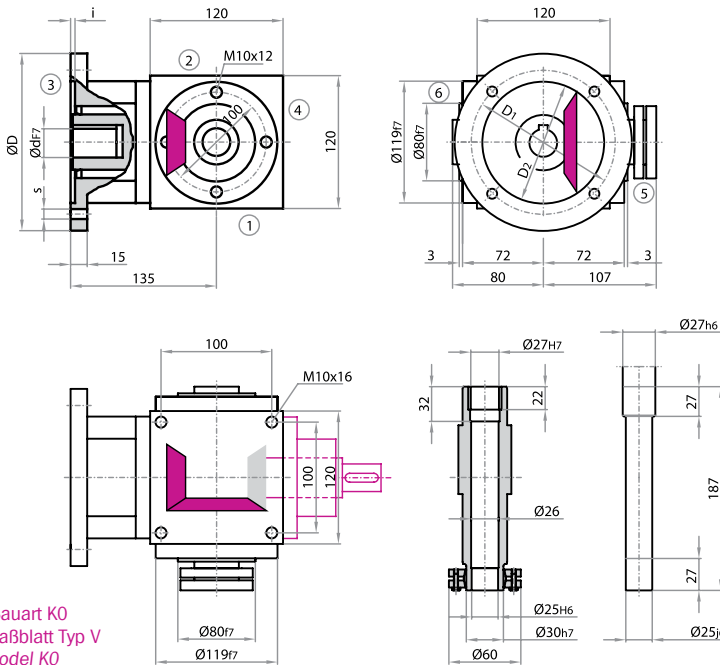
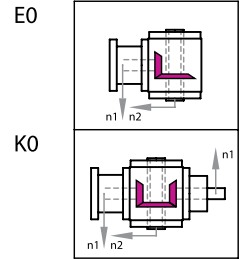

Zusatzflansch für Bauart K0
 Abmessungen siehe Maßblatt Typ V
 Additional flange for model K0
 For measurements refer to type V

Achtung: Standardbefestigungsgewinde im Gehäuse nur an den Seiten 1, 2 & 4. Alternativ auch an den Seiten 5 & 6 möglich.
Note: Standard fastening thread in the housing only on sides 1, 2 & 4. Alternatively, also possible on sides 5 & 6.

Bauart / Model

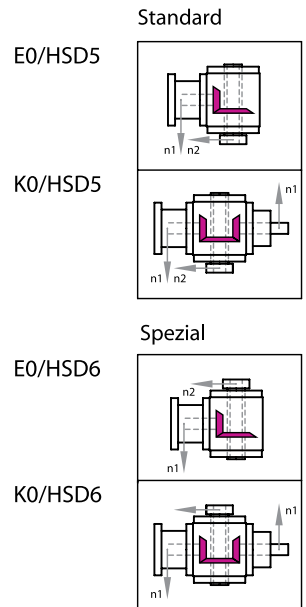

Abmessungen / Measurements

Flanschabmessungen / flange measurements				
D	D1	D2	s	i
140	115	95	9	3
160	130	110	9	4
200	165	130	11	4
250	215	180	14	5

passend für Motoranbau / fitted for motor attachment			
Baugröße / Size	D	Bauform / Design	Welle / shaft d
080	160 / 200	B 14 / B 5	19 x 40
090	160 / 200	B 14 / B 5	24 x 50
100	200 / 250	B 14 / B 5	28 x 60
112	200 / 250	B 14 / B 5	28 x 60

IV Leistungen, Drehmomente / Power Ratings, Torque Ratings

[n = min-1, P = kW, T = Nm]

i =	1:1	P1N	1,5:1	P1N	2:1	P1N	3:1	P1N	4:1	P1N	5:1	P1N	6:1	P1N
n1	n2	T2N	n2	T2N	n2	T2N	n2	T2N	n2	T2N	n2	T2N	n2	T2N
3000	3000	21,82	2000	13,45	1500	9,26	1000	6,39	750	4,96	600	3,97	500	2,95
		66,00		61,00		56,00		58,00		60,00		60,00		54,00
2400	2400	18,52	1600	11,46	1200	8,07	800	5,56	600	4,43	480	3,44	400	2,53
		70,00		65,00		61,00		63,00		67,00		65,00		57,00
1500	1500	13,56	1000	8,60	750	6,03	500	4,08	375	3,06	300	2,38	250	1,75
		82,00		78,00		73,00		74,00		74,00		72,00		64,00
1000	1000	10,14	667	6,32	500	4,40	333	3,01	250	2,18	200	1,76	167	1,22
		92,00		86,00		80,00		82,00		79,00		80,00		66,00
750	750	8,51	500	5,18	375	3,30	250	2,40	187,5	1,69	150	1,42	125	0,94
		103,00		94,00		80,00		87,00		82,00		86,00		68,00
500	500	6,34	333	3,70	250	2,20	167	1,66	125	1,16	100	0,98	83	0,63
		115,00		100,00		80,00		90,00		84,00		89,00		69,00
250	250	3,39	167	1,84	125	1,10	83	0,87	62,5	0,60	50	0,51	42	0,33
		123,00		100,00		80,00		95,00		87,00		92,00		71,00
50	50	0,72	33	0,37	25	0,22	17	0,21	12,5	0,12	10	0,10	8,3	0,06
		130,00		100,00		80,00		110,00		90,00		95,00		66,00
P1Nt		6,20		6,20		6,20		6,20		6,20		6,20		6,20
T2max		220,00		100,00		80,00		155,00		155,00		140,00		120,00

Radialkräfte / Radial Forces (N)

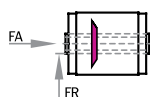

T2 Nm	3000	1000	n2 (1/min)	500	250	100	50
< 80	900	1200	1400	1700	2100	2500	
> 80	750	1000	1170	1420	1750	2080	

Weitere Erläuterungen und verstärkte Lagerungen siehe Allgemeines / For more information and reinforced bearings, refer to general information.
 Axialkräfte FA = 50% der Radialkräfte - siehe Allgemeines / Axial forces FA = 50% of radial forces - refer to general information.

Massenträgheitsmomente / Moments of Inertia J (kgcm²)

reduziert auf die Antriebswelle (n1) / reduced to the input shaft (n1)

Getriebegewichte Gearbox Weights (kg)

Bauart Model	Übersetzung / Transmission Ratios						
	1:1	1,5:1	2:1	3:1	4:1	5:1	6:1
E0	17,2787	9,4884	6,7014	5,4819	4,9125	4,6000	4,4453
K0	22,5275	11,9965	9,0357	7,2146	5,8008	5,1416	4,9761
E0/HSD	19,0660	10,2828	7,1482	5,6804	5,0242	4,6715	4,4950
K0/HSD	24,3148	12,7909	9,4825	7,4131	5,9125	5,2131	5,0258

Bauart Model	ca. Gewicht app. Weight
E0	15
K0	17,4
E0/HSD	15,3
K0/HSD	17,7

Abzug für Motorwellenbohrung / Reduction for motor shaft bore

Ø d x l	19x40 = -0,0502	24x50 = -0,1534	28x60 = -0,3126
---------	-----------------	-----------------	-----------------

V Befestigungsseite / Mounting Side

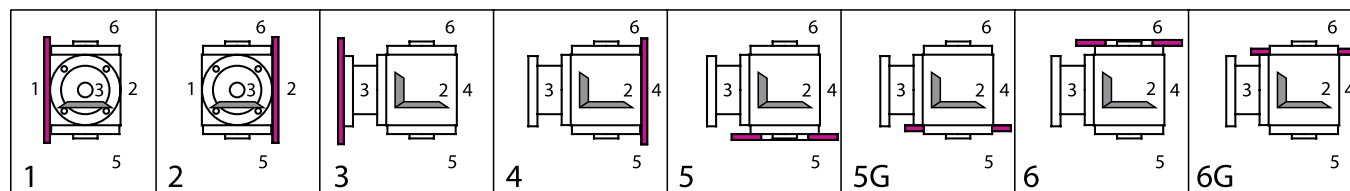

V Einbautagen (unten liegende Getriebeseite) / Mounting Configuration (downward-facing side)

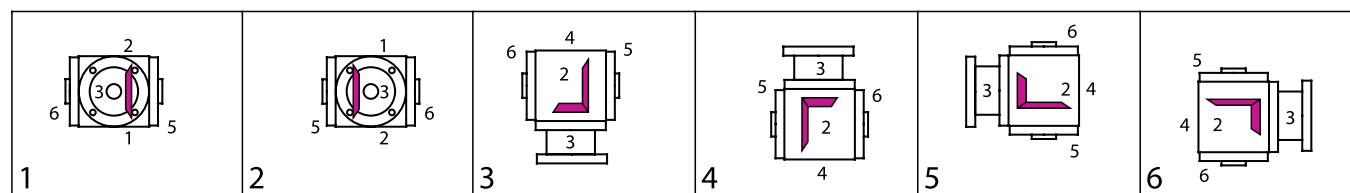

Bestellbeispiel / Example of Order

I Typ	Größe	IV Übersetzung	III Bauart	V Befestigungs-	VI Einbaulage	IV Drehzahl	Ausführung
Type	Size	Ratio	Model	Mounting Side	Mounting Config.	Speed	n2max
VL	120	3:1	E0	1	1	-	n2max
							500 / 0000=Standard
II	Ø Flansch	II	Welle (Ø x Länge)				
	Ø Flange		Shaft (Ø x length)				
	D 160		/ 19 x 40				

Kegelradgetriebe Typ V
Bevel Gearboxes Type V

Typ VL 140

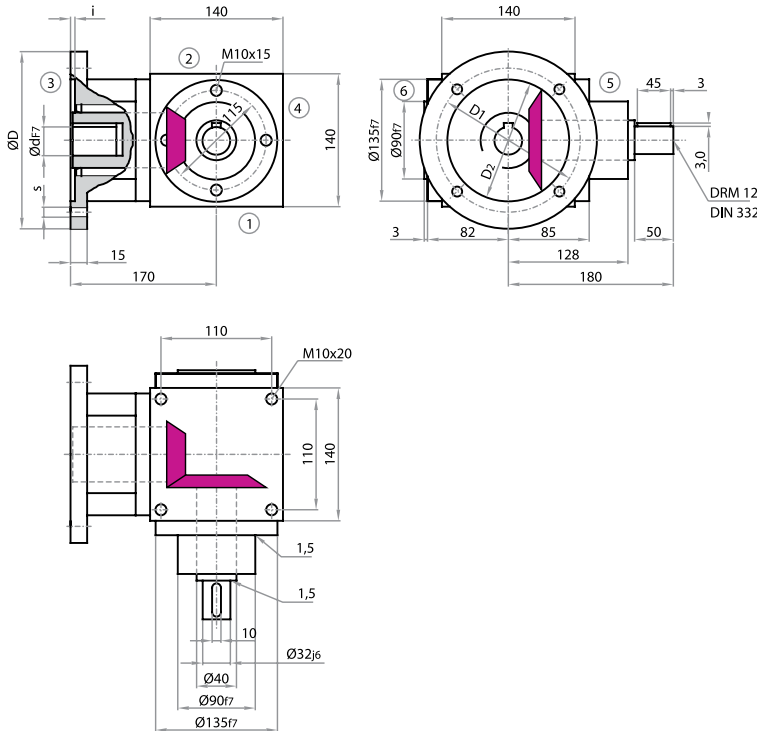

Achtung: Standardbefestigungsgewinde im Gehäuse nur an den Seiten 1, 2 & 4. Alternativ auch an den Seiten 5 & 6 möglich.
Note: Standard fastening thread in the housing only on sides 1, 2 & 4. Alternatively, also possible on sides 5 & 6.

Bauart / Model

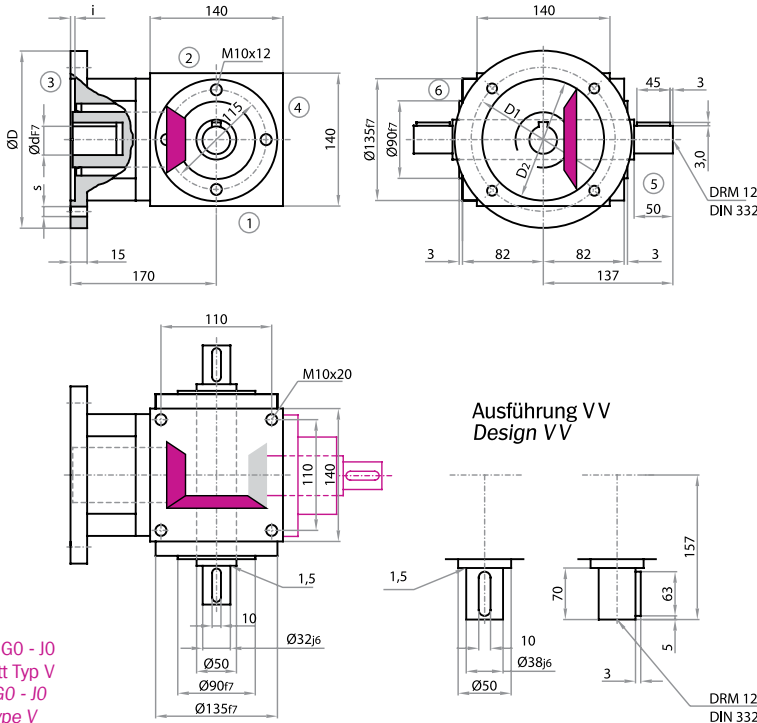
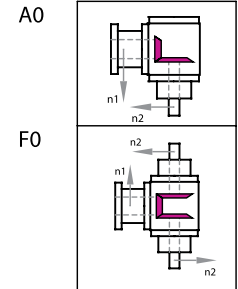

Zusatzflansch für Bauart G0 - J0
 Abmessungen siehe Maßblatt Typ V
 Additional flange for model G0 - J0
 For measurements refer to type V

Achtung: Standardbefestigungsgewinde im Gehäuse nur an den Seiten 1, 2 & 4. Alternativ auch an den Seiten 5 & 6 möglich.
Note: Standard fastening thread in the housing only on sides 1, 2 & 4. Alternatively, also possible on sides 5 & 6.

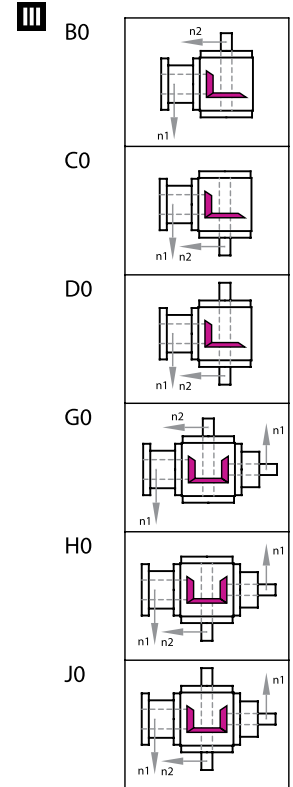

Abmessungen / Measurements

*Übersetzung 3:1 - 6:1 mit Zwischenflansch oder gekürzter Motorwelle
 Ratio 3:1 - 6:1 with flange or shortened motor shaft

Flanschabmessungen / flange measurements				
D	D1	D2	s	i
160	130	110	9	4
200	165	130	11	4
250	215	180	14	5

passend für Motoranbau / fitted for motor attachment			
Baugröße / Size	D	Bauform / Design	Welle / shaft d
090	160 / 200	B 14 / B 5	24 x 50
100 / 112	200 / 250	B 14 / B 5	28 x 60
132	200 / 250	B 14 / B 5	38 x 60/80*

IV Leistungen, Drehmomente / Power Ratings, Torque Ratings

[n = min-1, P = kW, T = Nm]

i =	1:1	P1N	1,5:1	P1N	2:1	P1N	3:1	P1N	4:1	P1N	5:1	P1N	6:1	P1N
n1	n2	T2N	n2	T2N	n2	T2N	n2	T2N	n2	T2N	n2	T2N	n2	T2N
3000	3000	39,68	2000	24,91	1500	16,53	1000	12,12	750	8,51	600	6,61	500	5,18
		120,00		113,00		100,00		110,00		103,00		100,00		94,00
2400	2400	37,04	1600	22,22	1200	14,68	800	11,46	600	7,34	480	5,56	400	4,58
		140,00		126,00		111,00		130,00		111,00		105,00		104,00
1500	1500	26,78	1000	17,08	750	11,41	500	8,05	375	4,96	300	3,80	250	2,95
		162,00		155,00		138,00		146,00		120,00		115,00		107,00
1000	1000	20,28	667	12,87	500	8,38	333	5,87	250	3,75	200	2,73	167	2,06
		184,00		175,00		152,00		160,00		136,00		124,00		112,00
750	750	16,20	500	10,47	375	6,86	250	4,60	187,5	3,06	150	2,15	125	1,61
		196,00		190,00		166,00		167,00		148,00		130,00		117,00
500	500	11,46	333	7,34	250	4,96	167	3,20	125	2,12	100	1,50	83	1,09
		208,00		200,00		180,00		174,00		154,00		136,00		119,00
250	250	5,92	167	3,76	125	2,48	83	1,62	62,5	1,12	50	0,79	42	0,56
		215,00		204,00		180,00		177,00		162,00		143,00		121,00
50	50	1,21	33	0,76	25	0,50	17	0,34	12,5	0,23	10	0,17	8,3	0,11
		220,00		210,00		180,00		180,00		170,00		150,00		120,00
P1Nt		10,00		10,00		10,00		10,00		10,00		10,00		10,00
T2max		430,00		210,00		180,00		280,00		280,00		250,00		200,00

Radialkräfte / Radial Forces (N)

T2 Nm	n2 (1/min)						T2 Nm	n2 (1/min)					
	3000	1000	500	250	100	50		3000	1000	500	250	100	50
< 140	700	870	1150	1370	1700	2000	< 140	1300	1700	2000	2500	3000	3800
> 140	590	730	960	1140	1420	1670	> 140	1083	1420	1670	2080	2500	3170

Weitere Erläuterungen und verstärkte Lagerungen siehe Allgemeines / For more information and reinforced bearings, refer to general information.

Axialkräfte FA = 50% der Radialkräfte - siehe Allgemeines / Axial forces FA = 50% of radial forces - refer to general information.

Massenträgheitsmomente / Moments of Inertia J (kgcm²)

reduziert auf die Antriebswelle (n1) / reduced to the input shaft (n1)

Bauart Model	Übersetzung / Transmission Ratios						
	1:1	1,5:1	2:1	3:1	4:1	5:1	6:1
A0	12,5824	6,9334	5,4003	4,7975	4,4628	4,2966	4,2267
F0	17,8312	9,2662	6,7125	5,3807	4,7908	4,5065	4,3725
B0, C0	17,3870	9,5366	6,7285	5,4939	4,9193	4,6043	4,4483
D0	17,6844	9,6687	6,8028	5,5269	4,9379	4,6162	4,4566
G0, H0	22,6358	12,0447	9,0628	7,2266	5,8076	5,1459	4,9791
J0	22,9332	12,1768	9,1371	7,2596	5,8262	5,1578	4,9874

Getriebegewichte

Gearbox Weights (kg)

Bauart Model	ca. Gewicht app. Weight
A0	24
F0	28
B0, C0	23,5
D0	24
G0, H0	27,7
J0	28,2

Abzug für Motorwellenbohrung / Reduction for motor shaft bore

Ø d x l	24x50 = -0,1534	28x60 = -0,3126	32x60 = -0,5253	38x60 = -1,0445	38x80 = -1,3659
---------	-----------------	-----------------	-----------------	-----------------	-----------------

V Befestigungsseite / Mounting Side

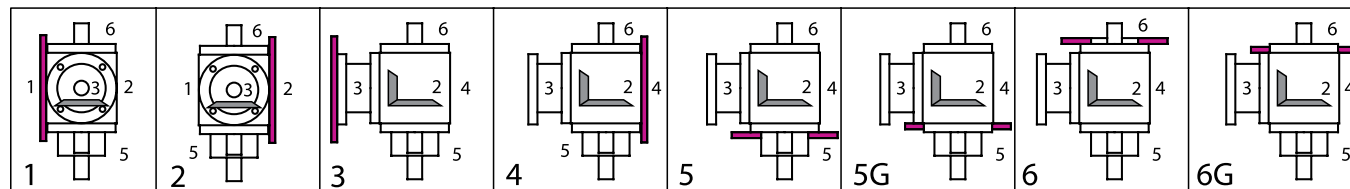

V Einbautagen (unten liegende Getriebeseite) / Mounting Configuration (downward-facing side)

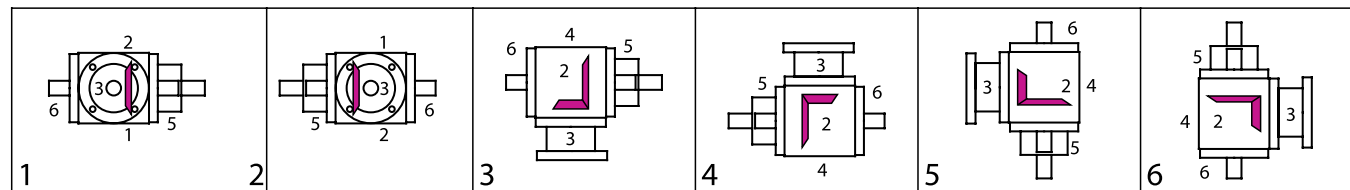

Bestellbeispiel / Example of Order

I Typ Type VL	Größe Size 140	IV Übersetzung Ratio 3:1	III Bauart Model A0	V Befestigungs- Mounting Side 1	VI Einbaulage Mounting Config. 1	IV Drehzahl n2max Speed n2max 500 / 0000=Standard	Ausführung Design
II Ø Flansch Ø Flange D 200	II Welle (Ø x Länge) Shaft (Ø x length) / 28 x 60						

Kegelradgetriebe Typ V
Bevel Gearboxes Type V

Typ VL 140

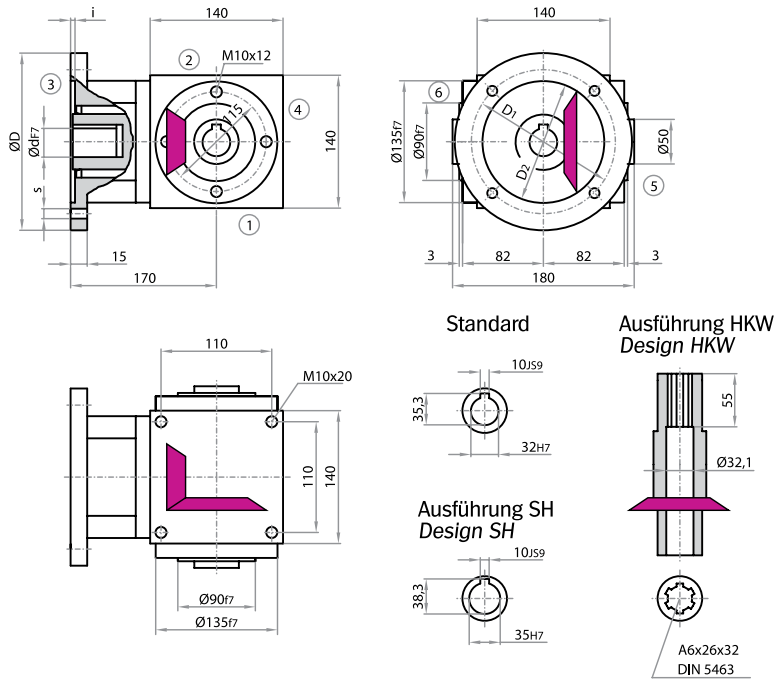

Bauart / Model

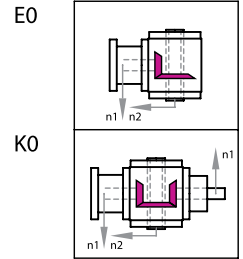

Achtung: Standardbefestigungsgewinde im Gehäuse nur an den Seiten 1, 2 & 4. Alternativ auch an den Seiten 5 & 6 möglich.
Note: Standard fastening thread in the housing only on sides 1, 2 & 4. Alternatively, also possible on sides 5 & 6.

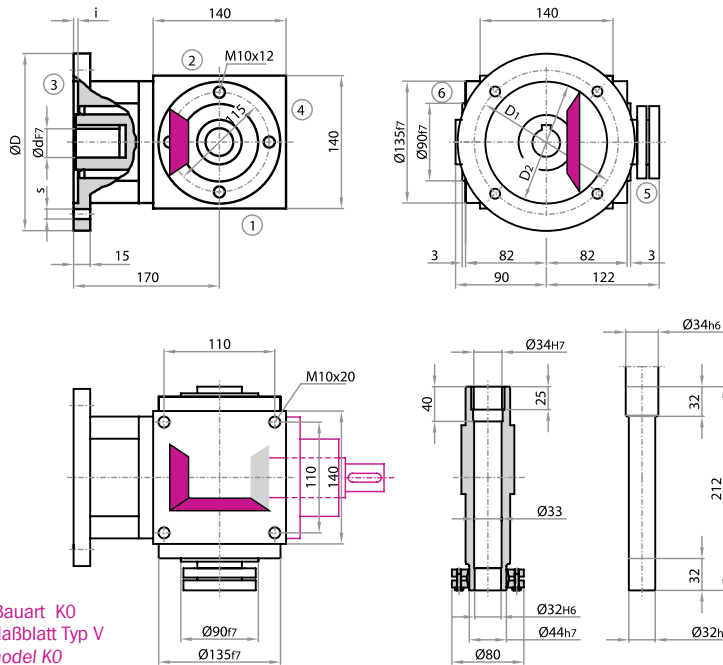

Bauart / Model

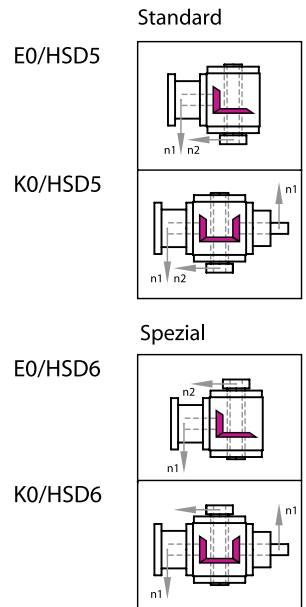

Zusatzflansch für Bauart K0
 Abmessungen siehe Maßblatt Typ V
 Additional flange for model K0
 For measurements refer to type V

Achtung: Standardbefestigungsgewinde im Gehäuse nur an den Seiten 1, 2 & 4. Alternativ auch an den Seiten 5 & 6 möglich.
Note: Standard fastening thread in the housing only on sides 1, 2 & 4. Alternatively, also possible on sides 5 & 6.

Abmessungen / Measurements

Flanschabmessungen / flange measurements				
D	D1	D2	s	i
160	130	110	9	4
200	165	130	11	4
250	215	180	14	5

*Übersetzung 3:1 - 6:1 mit Zwischenflansch oder gekürzter Motorwelle
 Ratio 3:1 - 6:1 with flange or shortened motor shaft

passend für Motoranbau / fitted for motor attachment			
Baugröße / Size	D	Bauform / Design	Welle / shaft d
090	160 / 200	B 14 / B 5	24 x 50
100 / 112	200 / 250	B 14 / B 5	28 x 60
132	200 / 250	B 14 / B 5	38 x 60/80*

IV Leistungen, Drehmomente / Power Ratings, Torque Ratings

[n = min-1, P = kW, T = Nm]

i =	1:1	P1N	1,5:1	P1N	2:1	P1N	3:1	P1N	4:1	P1N	5:1	P1N	6:1	P1N
n1	n2	T2N	n2	T2N	n2	T2N	n2	T2N	n2	T2N	n2	T2N	n2	T2N
3000	3000	39,68	2000	24,91	1500	16,53	1000	12,12	750	8,51	600	6,61	500	5,18
		120,00		113,00		100,00		110,00		103,00		100,00		94,00
2400	2400	37,04	1600	22,22	1200	14,68	800	11,46	600	7,34	480	5,56	400	4,58
		140,00		126,00		111,00		130,00		111,00		105,00		104,00
1500	1500	26,78	1000	17,08	750	11,41	500	8,05	375	4,96	300	3,80	250	2,95
		162,00		155,00		138,00		146,00		120,00		115,00		107,00
1000	1000	20,28	667	12,87	500	8,38	333	5,87	250	3,75	200	2,73	167	2,06
		184,00		175,00		152,00		160,00		136,00		124,00		112,00
750	750	16,20	500	10,47	375	6,86	250	4,60	187,5	3,06	150	2,15	125	1,61
		196,00		190,00		166,00		167,00		148,00		130,00		117,00
500	500	11,46	333	7,34	250	4,96	167	3,20	125	2,12	100	1,50	83	1,09
		208,00		200,00		180,00		174,00		154,00		136,00		119,00
250	250	5,92	167	3,76	125	2,48	83	1,62	62,5	1,12	50	0,79	42	0,56
		215,00		204,00		180,00		177,00		162,00		143,00		121,00
50	50	1,21	33	0,76	25	0,50	17	0,34	12,5	0,23	10	0,17	8,3	0,11
		220,00		210,00		180,00		180,00		170,00		150,00		120,00
P1Nt		10,00		10,00		10,00		10,00		10,00		10,00		10,00
T2max		430,00		210,00		180,00		280,00		280,00		250,00		200,00

Radialkräfte / Radial Forces (N)

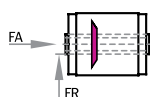

T2 Nm	3000	1000	n2 (1/min)	500	250	100	50
< 140	1300	1700	2000	2500	3000	3800	
> 140	1083	1420	1670	2080	2500	3170	

Weitere Erläuterungen und verstärkte Lagerungen siehe Allgemeines / For more information and reinforced bearings, refer to general information.
 Axialkräfte FA = 50% der Radialkräfte - siehe Allgemeines / Axial forces FA = 50% of radial forces - refer to general information.

Massenträgheitsmomente / Moments of Inertia J (kgcm²)

reduziert auf die Antriebswelle (n1) / reduced to the input shaft (n1)

Bauart Model	Übersetzung / Transmission Ratios						
	1:1	1,5:1	2:1	3:1	4:1	5:1	6:1
E0	42,4047	26,7092	20,7879	17,1127	15,5697	15,1763	14,8502
K0	55,5382	32,7290	26,1807	22,0890	16,5921	16,1830	15,8562
E0/HSD	48,8060	29,5543	22,3883	17,8240	15,9698	15,4323	15,0280
K0/HSD	61,9395	35,5741	27,7811	22,8003	16,9922	16,4390	16,0340

Getriebegewichte / Gearbox Weights (kg)

Bauart Model	ca. Gewicht app. Weight
E0	23
K0	27,2
E0/HSD	23,7
K0/HSD	27,9

Abzug für Motorwellenbohrung / Reduction for motor shaft bore

Ø d x l	24x50 = -0,1534	28x60 = -0,3126	32x60 = -0,5253	38x60 = -1,0445	38x80 = -1,3659
---------	-----------------	-----------------	-----------------	-----------------	-----------------

V Befestigungsseite / Mounting Side

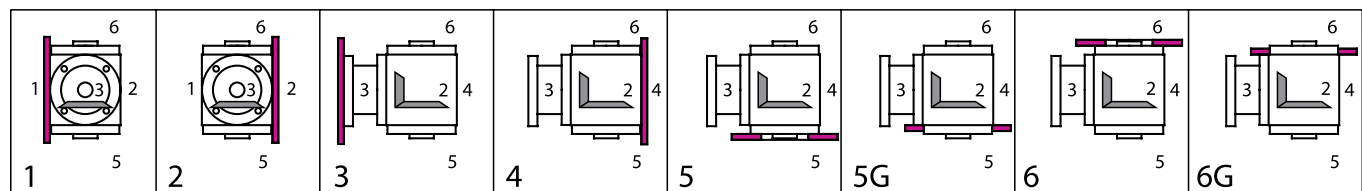

VI Einbautagen (unten liegende Getriebeseite) / Mounting Configuration (downward-facing side)

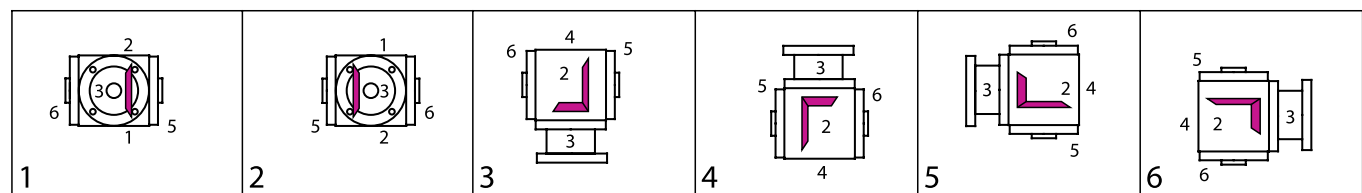

Bestellbeispiel / Example of Order

I Typ Type VL	Größe Size 140	IV Übersetzung Ratio 3:1	III Bauart Model E0	V Befestigungs- Mounting Side 1	VI Einbautage Mounting Config. 1	IV Drehzahl n2max Speed n2max 500 / 0000=Standard	Ausführung Design
II Ø Flansch Ø Flange D 200	II Welle (Ø x Länge) Shaft (Ø x length) / 28 x 60						

Kegelradgetriebe Typ V
Bevel Gearboxes Type V

Typ VL 160

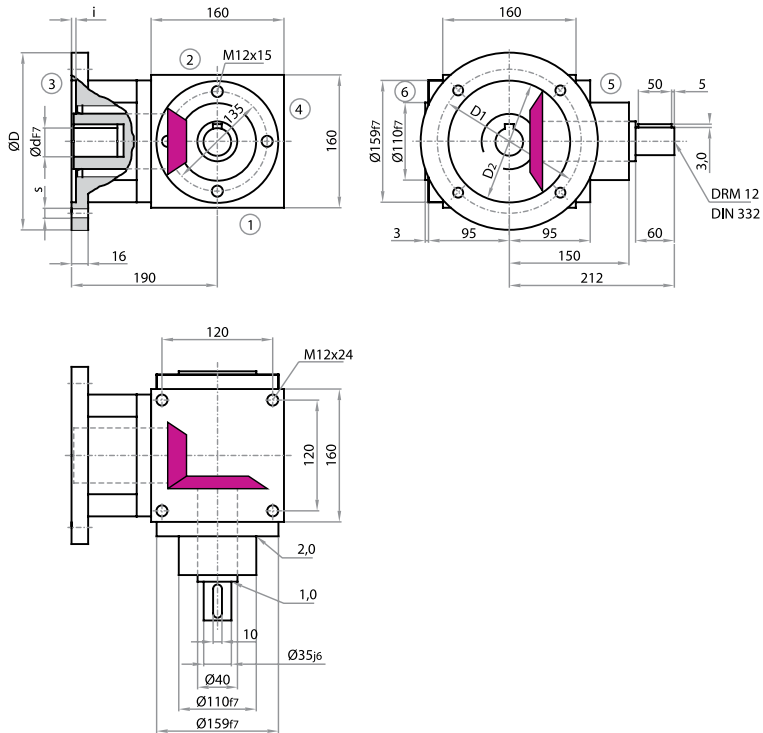

Bauart / Model

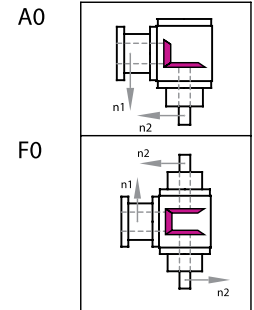

Achtung: Standardbefestigungsgewinde im Gehäuse nur an den Seiten 1, 2 & 4.
 Alternativ auch an den Seiten 5 & 6 im Rastermaß 130x130 möglich.
Note: Standard fastening thread in the housing only on sides 1, 2 & 4.
 Alternatively, also possible in the grid dimension of 130x130 on sides 5 & 6.

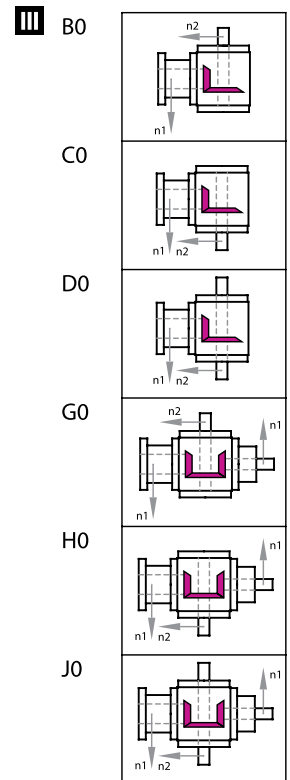
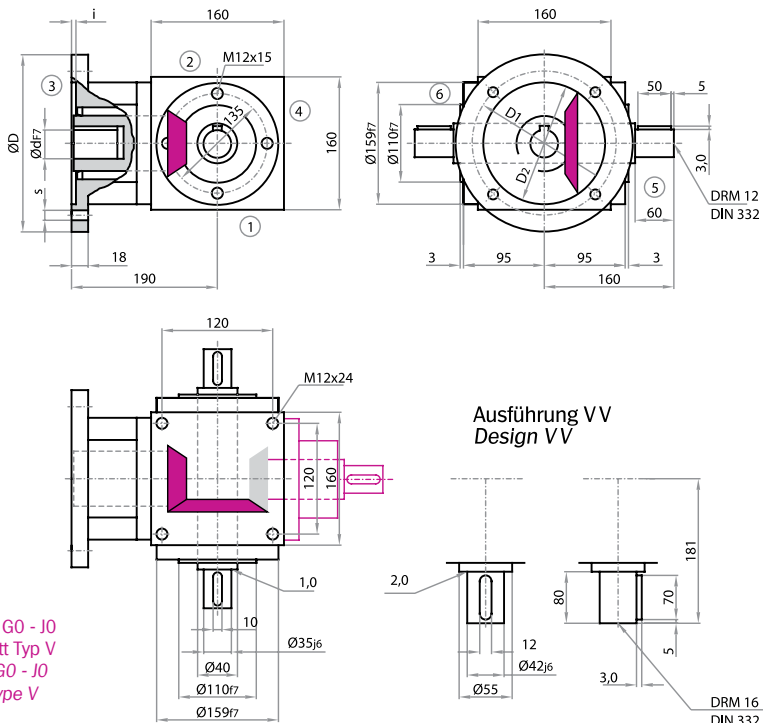

Zusatzflansch für Bauart G0 - J0
 Abmessungen siehe Maßblatt Typ V
 Additional flange for model G0 - J0
 For measurements refer to type V

Achtung: Standardbefestigungsgewinde im Gehäuse nur an den Seiten 1, 2 & 4.
 Alternativ auch an den Seiten 5 & 6 im Rastermaß 130x130 möglich.
Note: Standard fastening thread in the housing only on sides 1, 2 & 4.
 Alternatively, also possible in the grid dimension of 130x130 on sides 5 & 6.

Abmessungen / Measurements

Flanschabmessungen / flange measurements				
D	D1	D2	s	i
200	165	130	11	4
250	215	180	14	5
300	265	230	14	5

*Übersetzung 3:1 - 6:1 mit Zwischenflansch oder gekürzter Motorwelle
 Ratio 3:1 - 6:1 with flange or shortened motor shaft

passend für Motoranbau / fitted for motor attachment			
Baugröße / size	D	Bauform / Design	Welle / shaft d
100 / 112	200 / 250	B 14 / B 5	28 x 60
132	200 / 300	B 14 / B 5	38 x 80*

IV Leistungen, Drehmomente / Power Ratings, Torque Ratings

[n=min-1, P=kW, T=Nm]

i = n1	1:1 n2	P1N T2N	1,5:1 n2	P1N T2N	2:1 n2	P1N T2N	3:1 n2	P1N T2N	4:1 n2	P1N T2N	5:1 n2	P1N T2N	6:1 n2	P1N T2N
3000	3000		2000	40,78 185,00	1500	28,11 170,00	1000	20,94 190,00	750	14,88 180,00	600	11,90 180,00	500	7,09 129,00
2400	2400	57,67 218,00	1600	36,15 205,00	1200	25,53 193,00	800	17,81 202,00	600	13,23 200,00	480	10,48 198,00	400	5,98 136,00
1500	1500	42,99 260,00	1000	27,78 252,00	750	20,25 245,00	500	12,68 230,00	375	9,09 220,00	300	7,11 215,00	250	3,95 143,00
1000	1000	31,96 290,00	667	20,59 280,00	500	14,88 270,00	333	8,99 245,00	250	6,61 240,00	200	4,96 225,00	167	3,01 164,00
750	750	25,63 310,00	500	16,26 295,00	375	11,57 280,00	250	6,89 250,00	187,5	5,17 250,00	150	3,97 240,00	125	2,43 176,00
500	500	18,19 330,00	333	11,56 315,00	250	8,27 300,00	167	4,79 260,00	125	3,58 260,00	100	2,76 250,00	83	1,72 187,00
250	250	9,64 350,00	167	6,07 330,00	125	4,41 320,00	83	2,56 280,00	62,5	1,86 270,00	50	1,49 270,00	42	0,92 199,00
50	50	2,09 380,00	33	1,29 355,00	25	0,88 320,00	17	0,57 305,00	12,5	0,39 280,00	10	0,32 290,00	8,3	0,18 197,00
P1Nt		15,00		15,00		15,00		15,00		15,00		15,00		15,00
T2max		660,00		360,00		320,00		457,00		422,00		420,00		350,00

Radialkräfte / Radial Forces (N)

T2 Nm	n2 (1/min)					T2 Nm	n2 (1/min)					
	3000	1000	500	250	100		50	3000	1000	500	250	100
< 220	1200	1600	1900	2200	2850	3300	2000	2800	3300	4000	5000	6500
> 220	1000	1340	1590	1840	2380	2750	1670	2340	2750	3340	4170	5420

Weitere Erläuterungen und verstärkte Lagerungen siehe Allgemeines / For more information and reinforced bearings, refer to general information.
 Axialkräfte FA = 50% der Radialkräfte - siehe Allgemeines / Axial forces FA = 50% of radial forces - refer to general information.

Massenträgheitsmomente / Moments of Inertia J (kgcm²)

reduziert auf die Antriebswelle (n1) / reduced to the input shaft (n1)

Bauart Model	Übersetzung / Transmission Ratios						
	1:1	1,5:1	2:1	3:1	4:1	5:1	6:1
A0	42,4880	32,2050	25,0090	22,8169	21,8333	21,4119	21,2266
F0	57,3235	38,7985	28,7179	24,4653	22,7605	22,0053	21,6387
B0, C0	44,3697	44,5919	32,7507	25,9456	23,8183	22,8273	22,0772
D0	45,3990	45,0494	33,0080	26,0600	23,8826	22,8685	22,1058
G0, H0	59,2052	57,6357	41,4007	33,2488	29,3259	24,5072	23,7552
J0	60,2345	58,0932	41,6580	33,3632	29,3902	24,5484	23,7838

Getriebegewichte Gearbox Weights (kg)

ca. Gewicht
app. Weight

Bauart Model	ca. Gewicht app. Weight
A0	36,5
F0	43
B0, C0	36
D0	36,5
G0, H0	42,5
J0	43

Abzug für Motorwellenbohrung / Reduction for motor shaft bore

Ø d x l	24x50 = -0,1534	28x60 = -0,3126	32x60 = -0,5253	38x60 = -1,0445	38x80 = -1,3659
---------	-----------------	-----------------	-----------------	-----------------	-----------------

V Befestigungsseite / Mounting Side

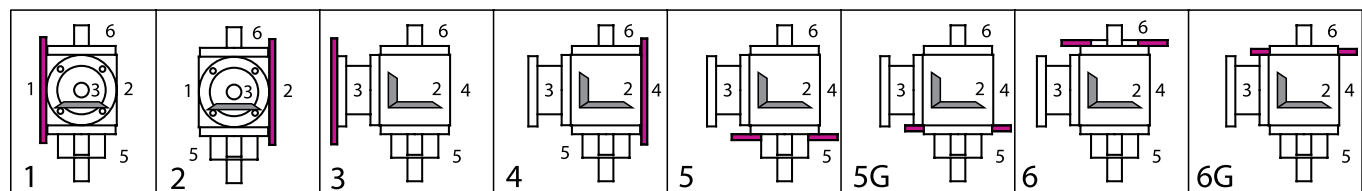

VI Einbautagen (unten liegende Getriebeseite) / Mounting Configuration (downward-facing side)

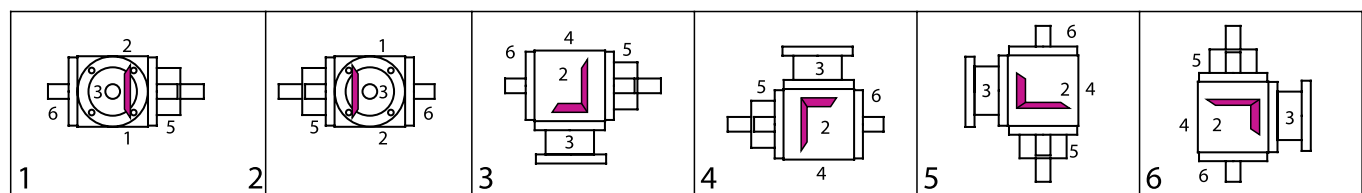

Bestellbeispiel / Example of Order

I Typ Type	Größe Size	IV Übersetzung Ratio	III Bauart Model	V Befestigungs- Mounting Side	VI Einbautage Mounting Config.	IV Drehzahl n2max Speed n2max	Ausführung Design
VL	160	5:1	A0	1	1	300 / 0000=Standard	
II	Ø Flansch Ø Flange D 200	III	Welle (Ø x Länge) Shaft (Ø x length) / 28 x 60				

Kegelradgetriebe Typ V
Bevel Gearboxes Type V

Typ VL 160

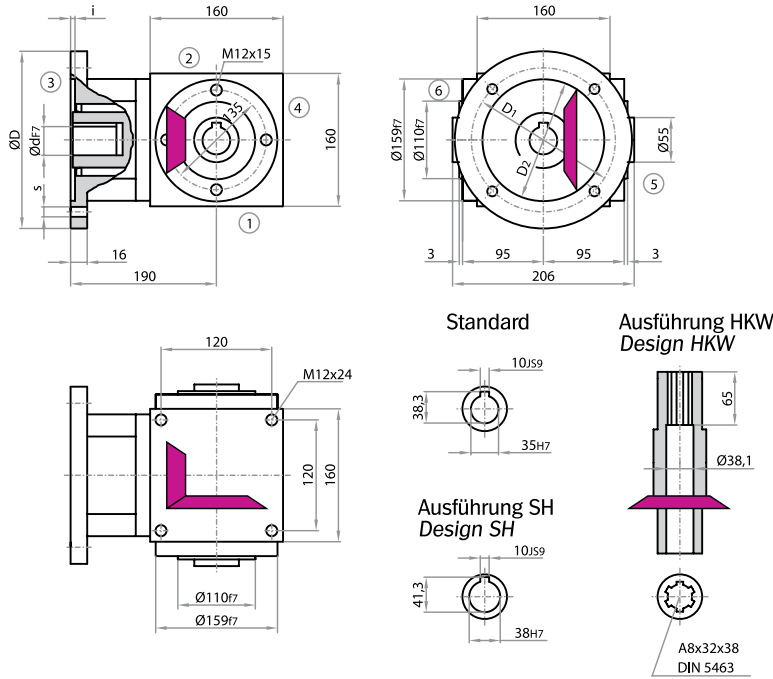

Achtung: Standardbefestigungsgewinde im Gehäuse nur an den Seiten 1, 2 & 4.
 Alternativ auch an den Seiten 5 & 6 im Rastermaß 130x130 möglich.
Note: Standard fastening thread in the housing only on sides 1, 2 & 4.
 Alternatively, also possible in the grid dimension of 130x130 on sides 5 & 6.

III Bauart / Model

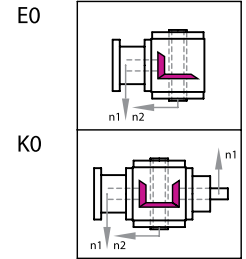

III Bauart / Model

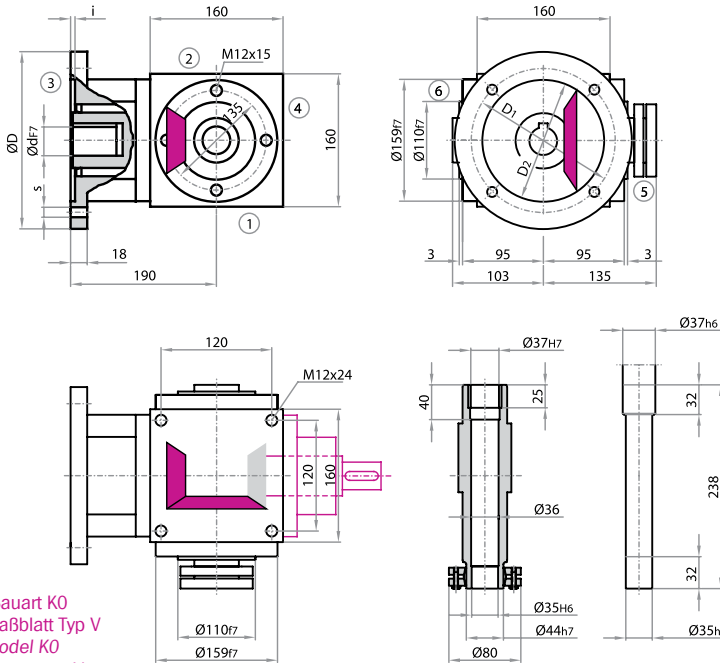

Zusatzflansch für Bauart K0
 Abmessungen siehe Maßblatt Typ V
 Additional flange for model K0
 For measurements refer to type V

Achtung: Standardbefestigungsgewinde im Gehäuse nur an den Seiten 1, 2 & 4.
 Alternativ auch an den Seiten 5 & 6 im Rastermaß 130x130 möglich.
Note: Standard fastening thread in the housing only on sides 1, 2 & 4.
 Alternatively, also possible in the grid dimension of 130x130 on sides 5 & 6.

III Bauart / Model

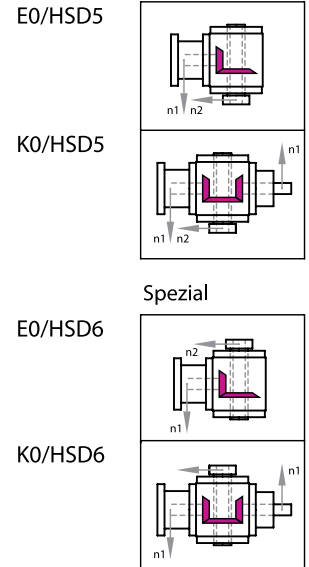

III Abmessungen / Measurements

Flanschabmessungen / flange measurements				
D	D1	D2	s	i
200	165	130	11	4
250	215	180	14	5
300	265	230	14	5

*Übersetzung 3:1 - 6:1 mit Zwischenflansch oder gekürzter Motorwelle
 Ratio 3:1 - 6:1 with flange or shortened motor shaft

passend für Motoranbau / fitted for motor attachment			
Baugröße / Size	D	Bauform / Design	Welle / shaft d
100 / 112	200 / 250	B 14 / B 5	28 x 60
132	200 / 300	B 14 / B 5	38 x 80*

IV Leistungen, Drehmomente / Power Ratings, Torque Ratings

[n = min-1, P = kW, T = Nm]

i =	1:1	P1N	1,5:1	P1N	2:1	P1N	3:1	P1N	4:1	P1N	5:1	P1N	6:1	P1N
n1	n2	T2N	n2	T2N	n2	T2N	n2	T2N	n2	T2N	n2	T2N	n2	T2N
3000	3000		2000	40,78	1500	28,11	1000	20,94	750	14,88	600	11,90	500	7,09
				185,00		170,00		190,00		180,00		180,00		129,00
2400	2400	57,67	1600	36,15	1200	25,53	800	17,81	600	13,23	480	10,48	400	5,98
		218,00		205,00		193,00		202,00		200,00		198,00		136,00
1500	1500	42,99	1000	27,78	750	20,25	500	12,68	375	9,09	300	7,11	250	3,95
		260,00		252,00		245,00		230,00		220,00		215,00		143,00
1000	1000	31,96	667	20,59	500	14,88	333	8,99	250	6,61	200	4,96	167	3,01
		290,00		280,00		270,00		245,00		240,00		225,00		164,00
750	750	25,63	500	16,26	375	11,57	250	6,89	187,5	5,17	150	3,97	125	2,43
		310,00		295,00		280,00		250,00		250,00		240,00		176,00
500	500	18,19	333	11,56	250	8,27	167	4,79	125	3,58	100	2,76	83	1,72
		330,00		315,00		300,00		260,00		260,00		250,00		187,00
250	250	9,64	167	6,07	125	4,41	83	2,56	62,5	1,86	50	1,49	42	0,92
		350,00		330,00		320,00		280,00		270,00		270,00		199,00
50	50	2,09	33	1,29	25	0,88	17	0,57	12,5	0,39	10	0,32	8,3	0,18
		380,00		355,00		320,00		305,00		280,00		290,00		197,00
P1Nt		15,00		15,00		15,00		15,00		15,00		15,00		15,00
T2max		660,00		360,00		320,00		457,00		422,00		420,00		350,00

Radialkräfte / Radial Forces (N)

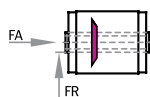

T2 Nm	3000	1000	n2 (1/min)	500	250	100	50
< 220	2300	3100	3600	4300	5300	7000	
> 220	1920	2580	3000	3580	4420	5830	

Weitere Erläuterungen und verstärkte Lagerungen siehe Allgemeines / For more information and reinforced bearings, refer to general information.

Axialkräfte FA = 50% der Radialkräfte - siehe Allgemeines / Axial forces FA = 50% of radial forces - refer to general information.

Massenträgheitsmomente / Moments of Inertia J (kgcm²)

reduziert auf die Antriebswelle (n1) / reduced to the input shaft (n1)

Bauart Model	1:1	1,5:1	2:1	3:1	4:1	5:1	6:1
E0	47,2021	45,7092	33,3159	26,1968	23,9596	22,9177	22,1413
K0	62,0376	58,7530	41,9659	33,5000	29,4672	24,5976	23,8193
E0/HSD	53,4920	48,5047	34,8883	26,8957	24,3527	23,1693	22,3160
K0/HSD	68,3275	61,5485	43,5383	34,1989	29,8603	24,8492	23,9940

Getriebegewichte

Gearbox Weights (kg)

Bauart Model	ca. Gewicht app. Weight
E0	35
K0	41,5
E0/HSD	35,6
K0/HSD	42,1

Abzug für Motorwellenbohrung / Reduction for motor shaft bore

Ø d x l	24x50 = -0,1534	28x60 = -0,3126	32x60 = -0,5253	38x60 = -1,0445	38x80 = -1,3659
---------	-----------------	-----------------	-----------------	-----------------	-----------------

V Befestigungsseite / Mounting Side

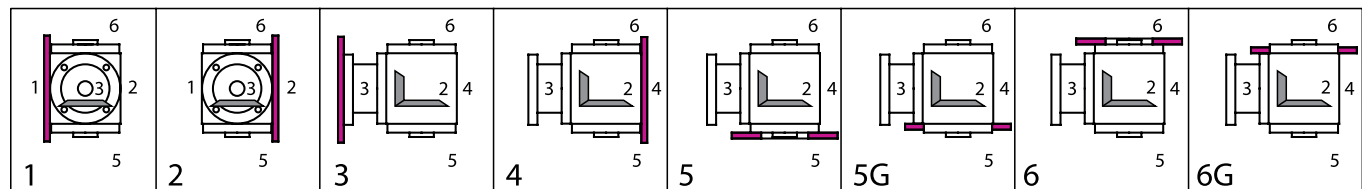

V Einbautagen (unten liegende Getriebeseite) / Mounting Configuration (downward-facing side)

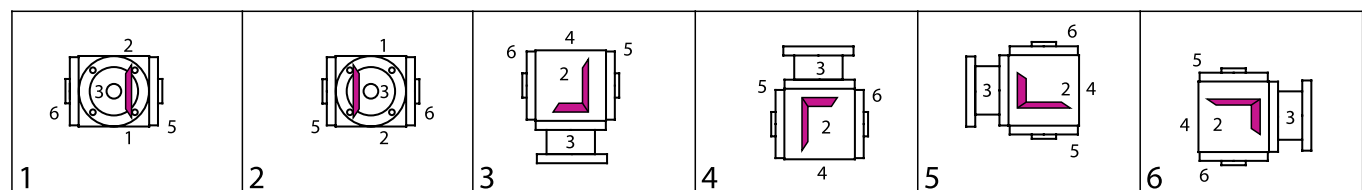

Bestellbeispiel / Example of Order

I Typ	Größe Size	IV Übersetzung Ratio	III Bauart Model	V Befestigungs- Mounting Side	VI Einbautage Mounting Config.	IV Drehzahl n2max Speed	Ausführung Design
VL	160	5:1	E0	1	1	300	0000=Standard
II	Ø Flansch Ø Flange D 200	III	Welle (Ø x Länge) Shaft (Ø x length) / 28 x 60				

Kegelradgetriebe Typ V
Bevel Gearboxes Type V

Typ VL 200

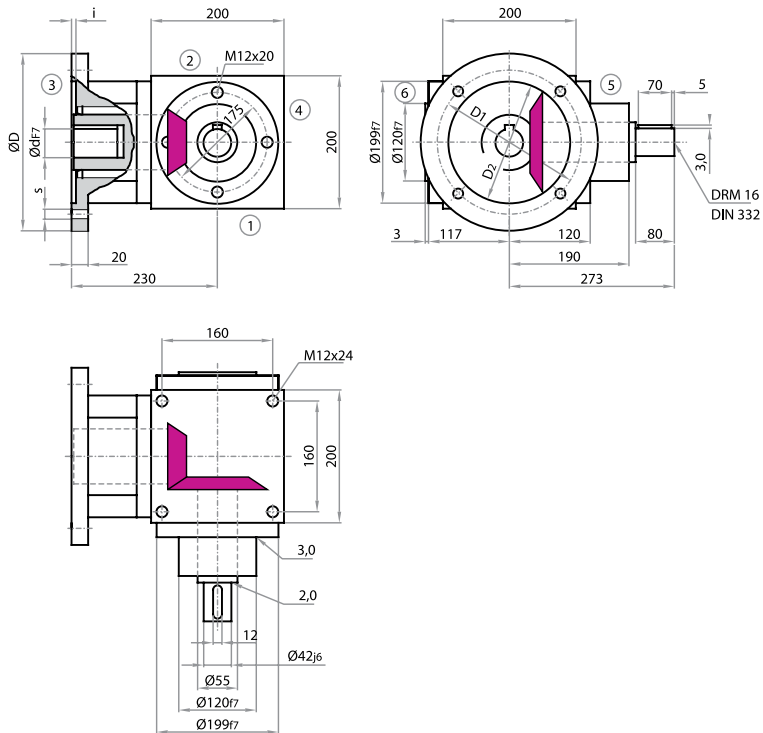

Bauart / Model

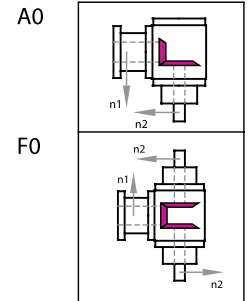

Achtung: Standardbefestigungsgewinde im Gehäuse nur an den Seiten 1, 2 & 4. Alternativ auch an den Seiten 5 & 6 möglich.
Note: Standard fastening thread in the housing only on sides 1, 2 & 4. Alternatively, also possible on sides 5 & 6.

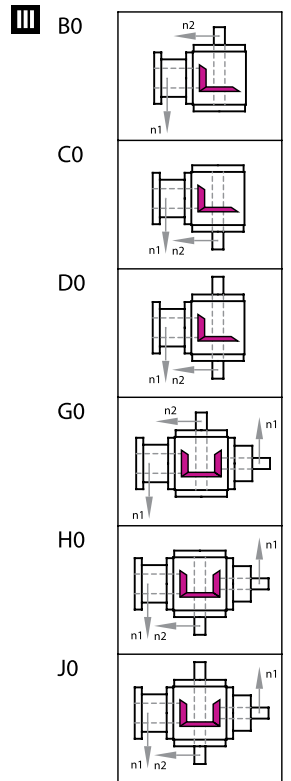
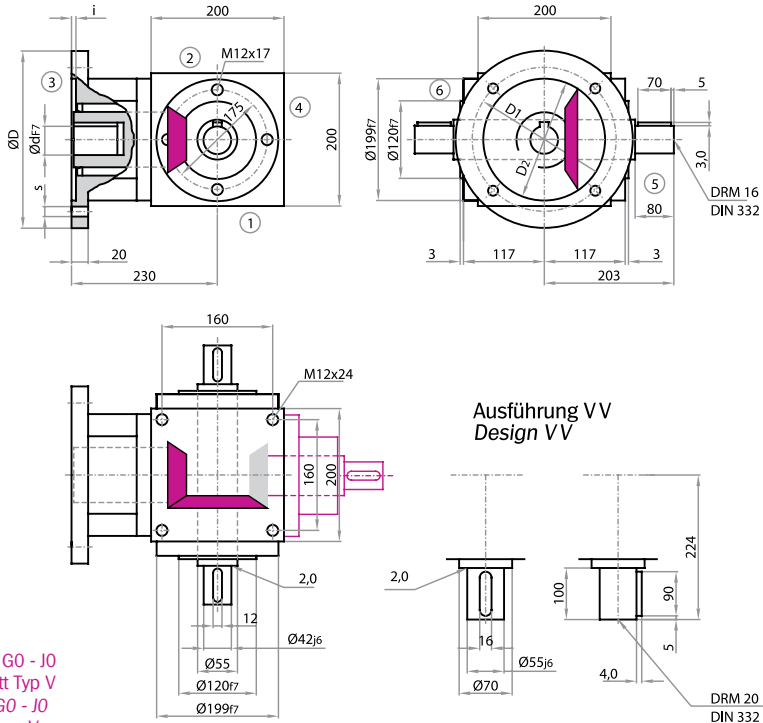

Zusatzflansch für Bauart G0 - J0
 Abmessungen siehe Maßblatt Typ V
 Additional flange for model G0 - J0
 For measurements refer to type V

Achtung: Standardbefestigungsgewinde im Gehäuse nur an den Seiten 1, 2 & 4. Alternativ auch an den Seiten 5 & 6 möglich.
Note: Standard fastening thread in the housing only on sides 1, 2 & 4. Alternatively, also possible on sides 5 & 6.

Abmessungen / Measurements

Flanschabmessungen / flange measurements				
D	D1	D2	s	i
200	165	130	11	4
250	215	180	14	5
300	265	230	14	5
350	300	250	18	6

*Übersetzung 3:1 - 6:1 mit Zwischenflansch oder gekürzter Motorwelle
 Ratio 3:1 - 6:1 with flange or shortened motor shaft

passend für Motoranbau / fitted for motor attachment			
Baugröße / Size	D	Bauform / Design	Welle / shaft d
100 / 112	200 / 250	B 14 / B 5	28 x 60
132	200 / 300	B 14 / B 5	38 x 80
160	350	B 5	42 x 80/110*
180	350	B 5	48 x 80/110*

IV Leistungen, Drehmomente / Power Ratings, Torque Ratings

[n=min-1, P=kW, T=Nm]

i = n1	1:1 n2	P1N T2N	1,5:1 n2	P1N T2N	2:1 n2	P1N T2N	3:1 n2	P1N T2N	4:1 n2	P1N T2N	5:1 n2	P1N T2N	6:1 n2	P1N T2N
3000	3000		2000	72,75 330,00	1500	51,25 310,00	1000	46,29 420,00	750	28,93 350,00	600	19,84 300,00	500	11,45 208,00
2400	2400		1600	63,49 360,00	1200	45,24 342,00	800	39,24 445,00	600	26,45 400,00	480	17,99 340,00	400	9,60 218,00
1500	1500	74,40 450,00	1000	48,17 437,00	750	35,13 425,00	500	28,38 515,00	375	18,81 455,00	300	12,57 380,00	250	6,54 237,00
1000	1000	56,21 510,00	667	37,13 505,00	500	27,56 500,00	333	20,37 555,00	250	13,36 485,00	200	9,26 420,00	167	4,74 258,00
750	750	45,88 555,00	500	30,31 550,00	375	21,90 530,00	250	15,98 580,00	187,5	10,54 510,00	150	7,27 440,00	125	3,98 289,00
500	500	34,17 620,00	333	22,02 600,00	250	14,60 530,00	167	11,04 600,00	125	7,23 525,00	100	5,18 470,00	83	2,79 304,00
250	250	19,56 710,00	167	11,04 600,00	125	7,30 530,00	83	5,76 630,00	62,5	3,79 550,00	50	2,78 505,00	42	1,44 311,00
50	50	4,13 750,00	33	2,18 600,00	25	1,46 530,00	17	1,29 690,00	12,5	0,80 580,00	10	0,58 525,00	8,3	0,28 306,00
P1Nt		26,00		26,00		26,00		26,00		26,00		26,00		26,00
T2max		1090,00		600,00		530,00		910,00		860,00		860,00		625,00

Radialkräfte / Radial Forces (N)

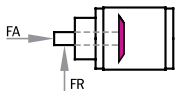

T2 Nm	n2 (1/min)					
	3000	1000	500	250	100	50
< 500	2200	1700	3200	3900	5000	6200
> 500	1840	1420	2670	3250	4170	5170

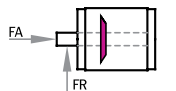

n2 (1/min)						
	3000	1000	500	250	100	50
	3200	4300	5000	6500	8000	10000
	2670	3580	4170	5420	6670	8330

Weitere Erläuterungen und verstärkte Lagerungen siehe Allgemeines / For more information and reinforced bearings, refer to general information.
 Axialkräfte FA = 50% der Radialkräfte - siehe Allgemeines / Axial forces FA = 50% of radial forces - refer to general information.

Massenträgheitsmomente / Moments of Inertia J (kgcm²)

reduziert auf die Antriebswelle (n1) / reduced to the input shaft (n1)

Bauart Model	Übersetzung / Transmission Ratios						
	1:1	1,5:1	2:1	3:1	4:1	5:1	6:1
A0	160,7940	103,3328	79,4024	66,6041	62,5170	60,9854	60,2444
F0	221,4201	130,2778	94,5590	73,3404	66,3062	63,4105	61,9285
B0, C0	214,2418	149,2207	114,7144	81,9650	70,9700	67,7153	64,9180
D0	217,3591	150,6062	115,4937	82,3114	71,1649	67,8400	65,0046
G0, H0	274,8679	179,9708	135,8674	94,0610	81,4460	71,4373	68,6220
J0	277,9852	181,3563	136,6467	94,4074	81,6409	71,5620	68,7086

Getriebegewichte

Gearbox Weights (kg)

Bauart Model	ca. Gewicht app. Weight
A0	64
F0	72
B0, C0	60
D0	62
G0, H0	70
J0	72

Abzug für Motorwellenbohrung / Reduction for motor shaft bore

Ø d x l	28x60 = -0,3126	32x60 = -0,5253	38x60 = -1,0445	38x80 = -1,3659	42x80 = -2,0384
---------	-----------------	-----------------	-----------------	-----------------	-----------------

V Befestigungsseite / Mounting Side

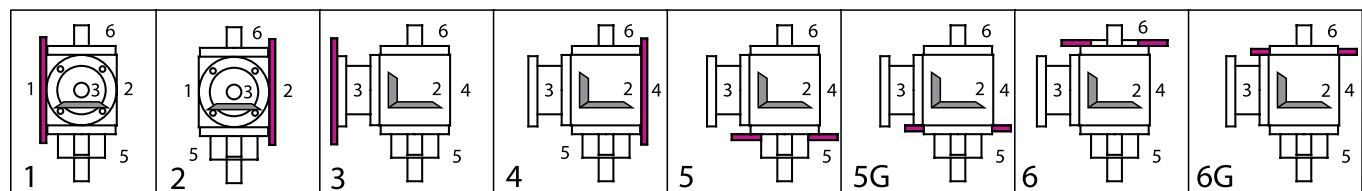

VI Einbautagen (unten liegende Getriebeseite) / Mounting Configuration (downward-facing side)

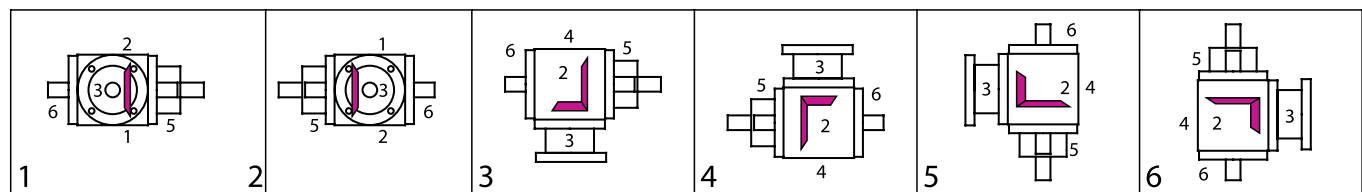

Bestellbeispiel / Example of Order

I Typ	Größe Size	IV Übersetzung Ratio	III Bauart Model	V Befestigungs- Mounting Side	VI Einbautage Mounting Config.	IV Drehzahl Speed	n2max n2max	Ausführung Design
VL	200	5:1	A0	1	1	-	300	0000=Standard
II	Ø Flansch Ø Flange D 250	III	Welle (Ø x Länge) Shaft (Ø x length) / 38 x 80					

Kegelradgetriebe Typ V
Bevel Gearboxes Type V

Typ VL 200

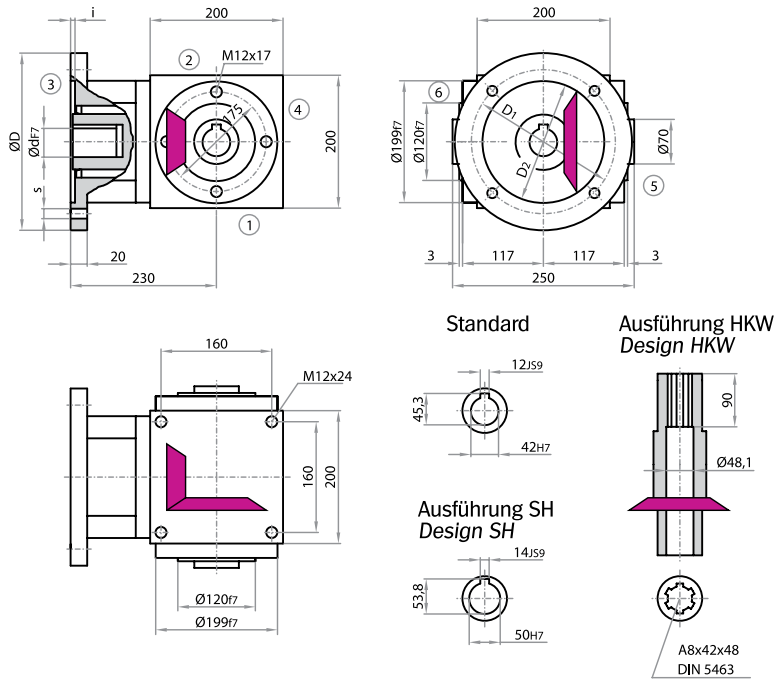

Bauart / Model

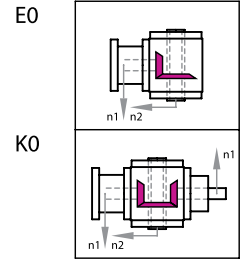

Achtung: Standardbefestigungsgewinde im Gehäuse nur an den Seiten 1, 2 & 4. Alternativ auch an den Seiten 5 & 6 möglich.
Note: Standard fastening thread in the housing only on sides 1, 2 & 4. Alternatively, also possible on sides 5 & 6.

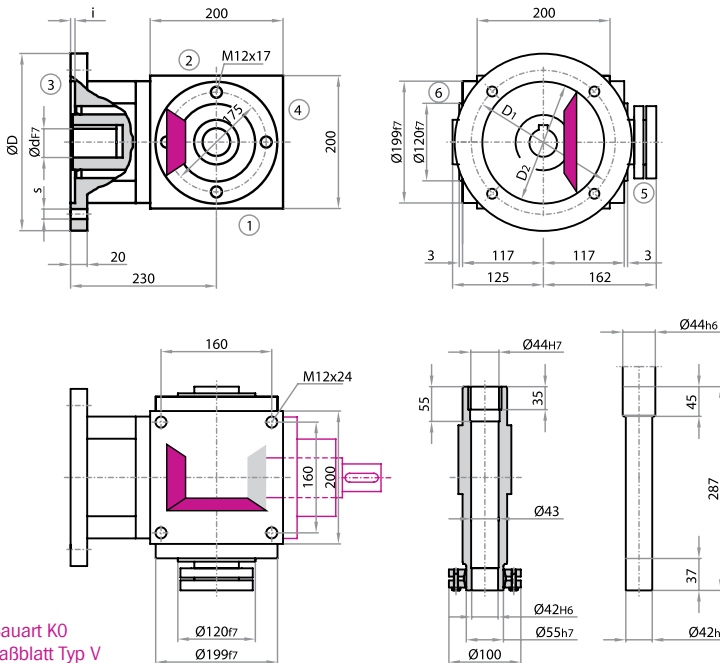

Bauart / Model

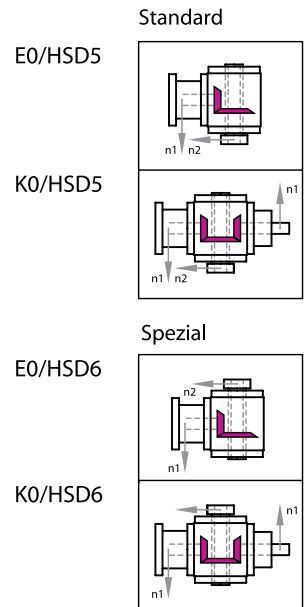

Zusatzflansch für Bauart K0
 Abmessungen siehe Maßblatt Typ V
 Additional flange for model K0
 For measurements refer to type V

Achtung: Standardbefestigungsgewinde im Gehäuse nur an den Seiten 1, 2 & 4. Alternativ auch an den Seiten 5 & 6 möglich.
Note: Standard fastening thread in the housing only on sides 1, 2 & 4. Alternatively, also possible on sides 5 & 6.

Abmessungen / Measurements

Flanschabmessungen / flange measurements				
D	D1	D2	s	i
200	165	130	11	4
250	215	180	14	5
300	265	230	14	5
350	300	250	18	6

*Übersetzung 3:1 - 6:1 mit Zwischenflansch oder gekürzter Motorwelle
 Ratio 3:1 - 6:1 with flange or shortened motor shaft

passend für Motoranbau / fitted for motor attachment			
Baugröße / Size	D	Bauform / Design	Welle / shaft d
100 / 112	200 / 250	B 14 / B 5	28 x 60
132	200 / 300	B 14 / B 5	38 x 80
160	350	B 5	42 x 80/110*
180	350	B 5	48 x 80/110*

IV Leistungen, Drehmomente / Power Ratings, Torque Ratings

[n=min-1, P=kW, T=Nm]

i = n1	1:1 n2	P1N T2N	1,5:1 n2	P1N T2N	2:1 n2	P1N T2N	3:1 n2	P1N T2N	4:1 n2	P1N T2N	5:1 n2	P1N T2N	6:1 n2	P1N T2N
3000	3000		2000	72,75 330,00	1500	51,25 310,00	1000	46,29 420,00	750	28,93 350,00	600	19,84 300,00	500	11,45 208,00
2400	2400		1600	63,49 360,00	1200	45,24 342,00	800	39,24 445,00	600	26,45 400,00	480	17,99 340,00	400	9,60 218,00
1500	1500	74,40 450,00	1000	48,17 437,00	750	35,13 425,00	500	28,38 515,00	375	18,81 455,00	300	12,57 380,00	250	6,54 237,00
1000	1000	56,21 510,00	667	37,13 505,00	500	27,56 500,00	333	20,37 555,00	250	13,36 485,00	200	9,26 420,00	167	4,74 258,00
750	750	45,88 555,00	500	30,31 550,00	375	21,90 530,00	250	15,98 580,00	187,5	10,54 510,00	150	7,27 440,00	125	3,98 289,00
500	500	34,17 620,00	333	22,02 600,00	250	14,60 530,00	167	11,04 600,00	125	7,23 525,00	100	5,18 470,00	83	2,79 304,00
250	250	19,56 710,00	167	11,04 600,00	125	7,30 530,00	83	5,76 630,00	62,5	3,79 550,00	50	2,78 505,00	42	1,44 311,00
50	50	4,13 750,00	33	2,18 600,00	25	1,46 530,00	17	1,29 690,00	12,5	0,80 580,00	10	0,58 525,00	8,3	0,28 306,00
P1Nt		26,00		26,00		26,00		26,00		26,00		26,00		26,00
T2max		1090,00		600,00		530,00		910,00		860,00		860,00		625,00

Radialkräfte / Radial Forces (N)

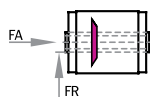

T2 Nm	n2 (1/min)					
	3000	1000	500	250	100	50
< 500	3600	4700	5400	7200	9000	11000
> 500	3000	3900	4500	6000	7500	9200

Weitere Erläuterungen und verstärkte Lagerungen siehe Allgemeines / For more information and reinforced bearings, refer to general information.
 Axialkräfte FA = 50% der Radialkräfte - siehe Allgemeines / Axial forces FA = 50% of radial forces - refer to general information.

Massenträgheitsmomente / Moments of Inertia J (kgcm²)

reduziert auf die Antriebswelle (n1) / reduced to the input shaft (n1)

Bauart Model	Übersetzung / Transmission Ratios						
	1:1	1,5:1	2:1	3:1	4:1	5:1	6:1
E0	240,9322	154,6654	119,5270	82,9928	71,6107	68,6453	65,5638
K0	301,5583	185,4155	140,6800	95,0888	82,0867	72,3673	69,2678
E0/HSD	261,9542	164,0085	124,7825	85,3286	72,9245	69,4862	66,1478
K0/HSD	322,5803	194,7586	145,9355	97,4246	83,4005	73,2082	69,8518

Getriebegewichte

Gearbox Weights (kg)

Bauart Model	ca. Gewicht app. Weight
E0	60
K0	70
E0/HSD	61,3
K0/HSD	71,3

Abzug für Motorwellenbohrung / Reduction for motor shaft bore

Ø d x l	28x60 = -0,3126	32x60 = -0,5253	38x60 = -1,0445	38x80 = -1,3659	42x80 = -2,0384
---------	-----------------	-----------------	-----------------	-----------------	-----------------

V Befestigungsseite / Mounting Side

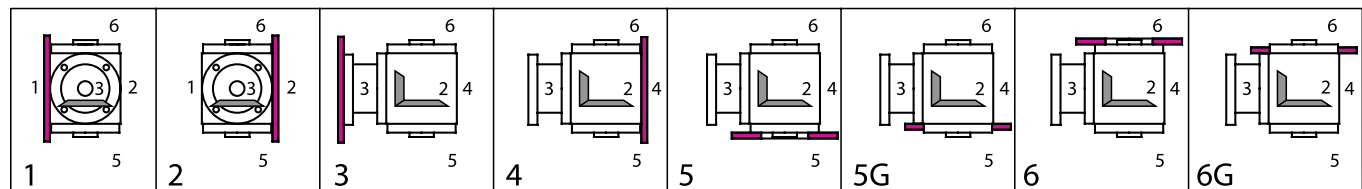

V Einbautagen (unten liegende Getriebeseite) / Mounting Configuration (downward-facing side)

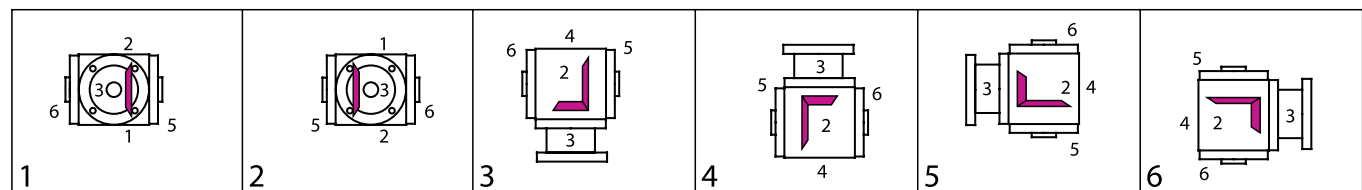

Bestellbeispiel / Example of Order

I Typ	Größe Size	IV Übersetzung Ratio	III Bauart Model	V Befestigungs- Mounting Side	VI Einbaulage Mounting Config.	IV Drehzahl Speed	n2max n2max	Ausführung Design
VL	200	5:1	E0	1	1	-	300 / 0000=Standard	
II	Ø Flansch Ø Flange D 250		III	Welle (Ø x Länge) Shaft (Ø x length) / 38 x 80				

Kegelradgetriebe Typ V
Bevel Gearboxes Type V

IV Leistungen, Drehmomente / Power Ratings, Torque Ratings

[n=min-1, P=kW, T=Nm]

i = n1	1:1 n2	P1N T2N	1,5:1 n2	P1N T2N	2:1 n2	P1N T2N	3:1 n2	P1N T2N	4:1 n2	P1N T2N	5:1 n2	P1N T2N	6:1 n2	P1N T2N
3000	3000		2000	99,2 450	1500	87,63 530	1000	44,09 400	750	36,37 440	600	33,73 510	500	20,17 366
2400	2400		1600	91,35 518	1200	80,02 605	800	39,68 450	600	32,74 495	480	29,1 550	400	18,08 410
1500	1500	87,63 530	1000	72,2 655	750	59,11 715	500	29,76 540	375	24,8 600	300	21 635	250	13,5 490
1000	1000	71,65 650	667	56,21 765	500	45,19 820	333	23,33 635	250	18,6 675	200	15,76 715	167	9,92 540
750	750	60,76 735	500	45,47 825	375	36,79 890	250	19,29 700	187,5	15,19 735	150	12,73 770	125	7,78 565
500	500	45,19 820	333	33,79 920	250	26,73 970	167	14,07 765	125	10,95 795	100	9,15 830	83	5,42 590
250	250	26,73 970	167	20,57 1120	125	16,88 1225	83	7,58 825	62,5	5,99 870	50	5,07 920	42	2,82 610
50	50	7 1270	33	4,89 1330	25	3,66 1330	17	1,633 870	12,5	1,35 980	10	1,09 990	8,3	0,57 625
P1Nt		34		34		34		34		34		34		34
T2max		1500		1400		1400		1300		1300		1200		1000

Radialkräfte / Radial Forces (N)

FA	FR	T2 Nm	n2 (1/min)						FA	FR	T2 Nm	n2 (1/min)					
			3000	1000	500	250	100	50				3000	1000	500	250	100	50
<		750	4600	5150	7200	9450	11250	13100			5850	8650	10500	12250	15000	19000	
>		750	3830	4290	6000	7870	9370	10920			4870	7210	8750	10210	12500	15830	

Weitere Erläuterungen und verstärkte Lagerungen siehe Allgemeines / For more information and reinforced bearings, refer to general information.
 Axialkräfte FA = 50% der Radialkräfte - siehe Allgemeines / Axial forces FA = 50% of radial forces - refer to general information.

Massenträgheitsmomente Moments of Inertia

Bauart Model	Übersetzung / Transmission Ratios						
	1:1	1,5:1	2:1	3:1	4:1	5:1	6:1
	auf Anfrage upon request						

Getriebegewichte Gearbox Weights (kg)

Bauart Model	ca. Gewicht app. Weight
A0	94
F0	112
B0, C0	112
D0	91
G0, H0	115
J0	117

V Befestigungsseite / Mounting Side

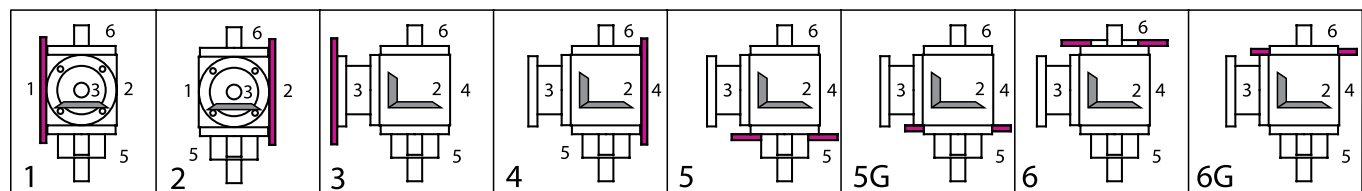

VI Einbautagen (unten liegende Getriebeseite) / Mounting Configuration (downward-facing side)

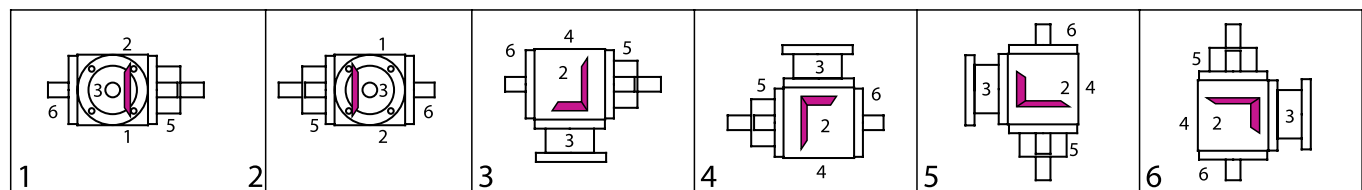

Bestellbeispiel / Example of Order

I Typ	Größe Size	IV Übersetzung Ratio	III Bauart Model	V Befestigungs- Mounting Side	VI Einbautage Mounting Config.	IV Drehzahl n2max Speed n2max	Ausführung Design
VL	230	5:1	A0	1	1	300 / 0000=Standard	
II ø Flansch ø Flange	II Welle (ø x Länge) Shaft (ø x length)						
D 300	/ 38 x 80						

Kegelradgetriebe Typ V
Bevel Gearboxes Type V

Typ VL 230

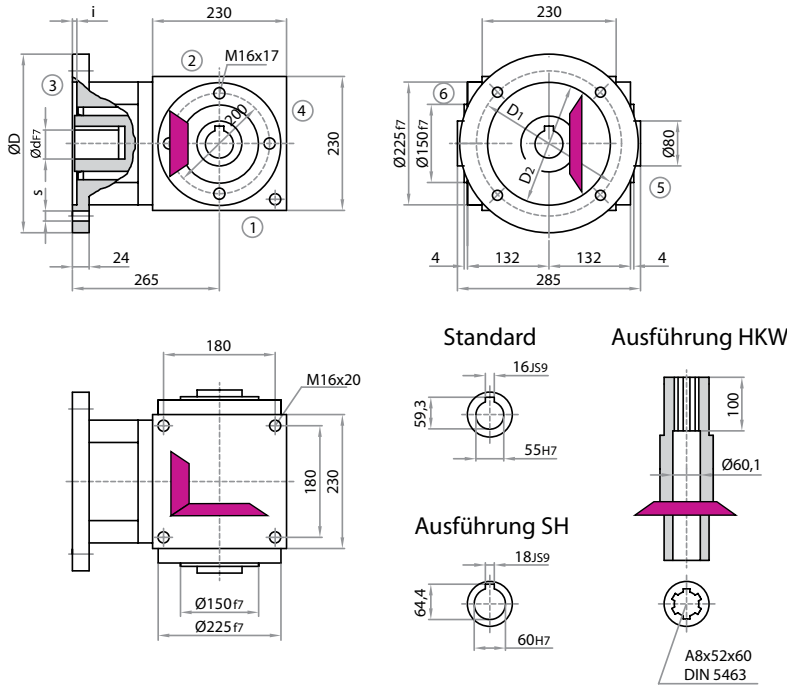

Bauart / Model

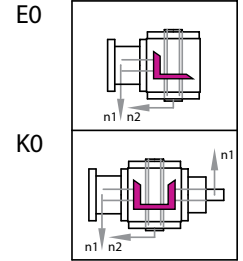

Achtung: Standardbefestigungsgewinde im Gehäuse nur an den Seiten 1, 2 & 4. Alternativ auch an den Seiten 5 & 6 möglich.
Note: Standard fastening thread in the housing only on sides 1, 2 & 4. Alternatively, also possible on sides 5 & 6.

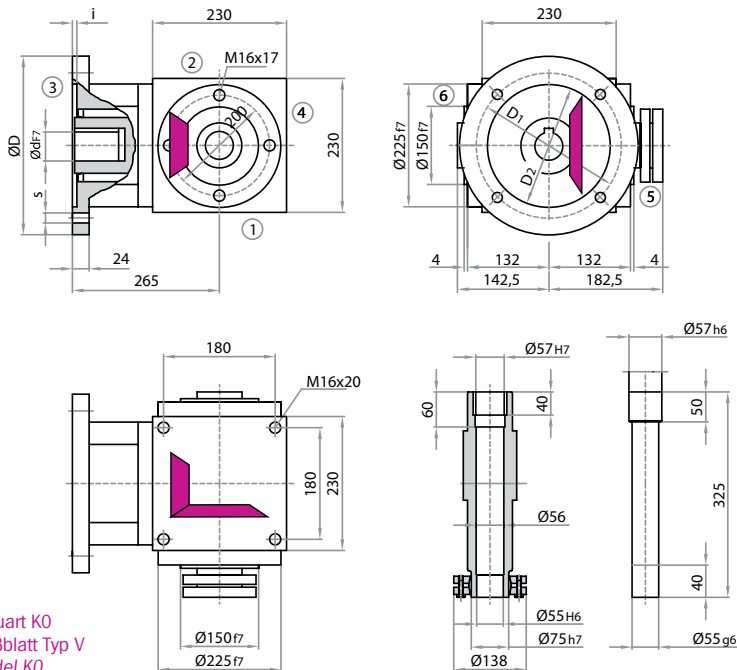

Bauart / Model

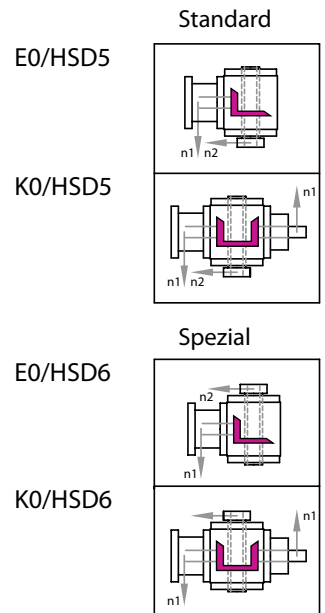

Zusatzflansch für Bauart K0
 Abmessungen siehe Maßblatt Typ V
 Additional flange for model K0
 For measurements refer to type V

Achtung: Standardbefestigungsgewinde im Gehäuse nur an den Seiten 1, 2 & 4. Alternativ auch an den Seiten 5 & 6 möglich.
Note: Standard fastening thread in the housing only on sides 1, 2 & 4. Alternatively, also possible on sides 5 & 6.

Abmessungen / Measurements

Flanschabmessungen / flange measurements				
D	D1	D2	s	i
300	265	230	14	5
350	300	250	18	6
400	350	300	18	6
450	400	350	18	6

passend für Motoranbau / fitted for motor attachment			
Baugröße / Size	D	Bauform / Design	Welle / shaft d
132	300	B 5	38 x 80
160	350	B 5	42 x 80/110
180	350	B 5	48 x 80/110
200	400	B 5	55 x 110

IV Leistungen, Drehmomente / Power Ratings, Torque Ratings

[n = min-1, P = kW, T = Nm]

i = n1	1:1 n2	P1N T2N	1,5:1 n2	P1N T2N	2:1 n2	P1N T2N	3:1 n2	P1N T2N	4:1 n2	P1N T2N	5:1 n2	P1N T2N	6:1 n2	P1N T2N
3000	3000		2000	99,2 450	1500	87,63 530	1000	44,09 400	750	36,37 440	600	33,73 510	500	20,17 366
2400	2400		1600	91,35 518	1200	80,02 605	800	39,68 450	600	32,74 495	480	29,1 550	400	18,08 410
1500	1500	87,63 530	1000	72,2 655	750	59,11 715	500	29,76 540	375	24,8 600	300	21 635	250	13,5 490
1000	1000	71,65 650	667	56,21 765	500	45,19 820	333	23,33 635	250	18,6 675	200	15,76 715	167	9,92 540
750	750	60,76 735	500	45,47 825	375	36,79 890	250	19,29 700	187,5	15,19 735	150	12,73 770	125	7,78 565
500	500	45,19 820	333	33,79 920	250	26,73 970	167	14,07 765	125	10,95 795	100	9,15 830	83	5,42 590
250	250	26,73 970	167	20,57 1120	125	16,88 1225	83	7,58 825	62,5	5,99 870	50	5,07 920	42	2,82 610
50	50	7 1270	33	4,89 1330	25	3,66 1330	17	1,633 870	12,5	1,35 980	10	1,09 990	8,3	0,57 625
P1Nt		34		34		34		34		34		34		34
T2max		1500		1400		1400		1300		1300		1200		1000

Radialkräfte / Radial Forces (N)

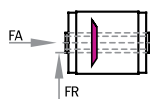

T2 Nm	3000	1000	n2 (1/min) 500	250	100	50
< 750	5850	8650	10500	12250	15000	19000
> 750	4870	7210	8750	10210	12500	15830

Weitere Erläuterungen und verstärkte Lagerungen siehe Allgemeines / For more information and reinforced bearings, refer to general information.

Axialkräfte FA = 50% der Radialkräfte - siehe Allgemeines / Axial forces FA = 50% of radial forces - refer to general information.

Massenträgheitsmomente Moments of Inertia

Bauart Model	Übersetzung / Transmission Ratios					
	1:1	1,5:1	2:1	3:1	4:1	5:1
	auf Anfrage upon request					

Getriebegewichte Gearbox Weights (kg)

Bauart Model	ca. Gewicht app. Weight
E0	86
K0	110
E0/HSD	87
K0/HSD	111

V Befestigungsseite / Mounting Side

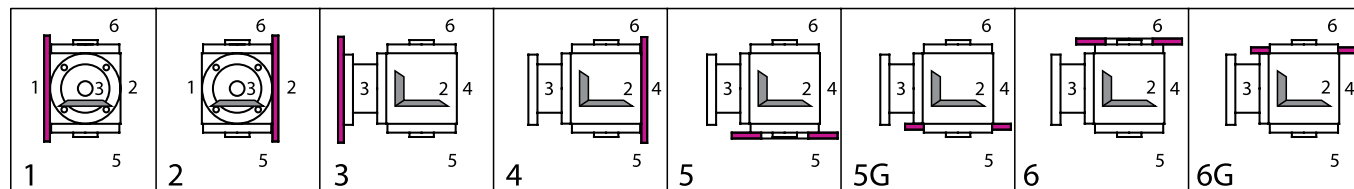

VI Einbautagen (unten liegende Getriebeseite) / Mounting Configuration (downward-facing side)

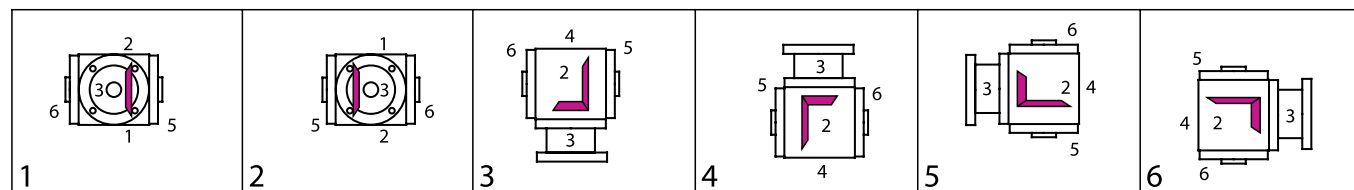

Bestellbeispiel / Example of Order

I Typ	Größe Size	IV Übersetzung Ratio	III Bauart Model	V Befestigungs- Mounting Side	VI Einbautage Mounting Config.	IV Drehzahl n2max Speed n2max	Ausführung Design
VL	230	5:1	E0	1	1	200 / 0000=Standard	
II ø Flansch ø Flange D 300		II Welle (ø x Länge) Shaft (ø x length) / 38 x 80					

Kegelradgetriebe Typ V
Bevel Gearboxes Type V

Typ VL 260

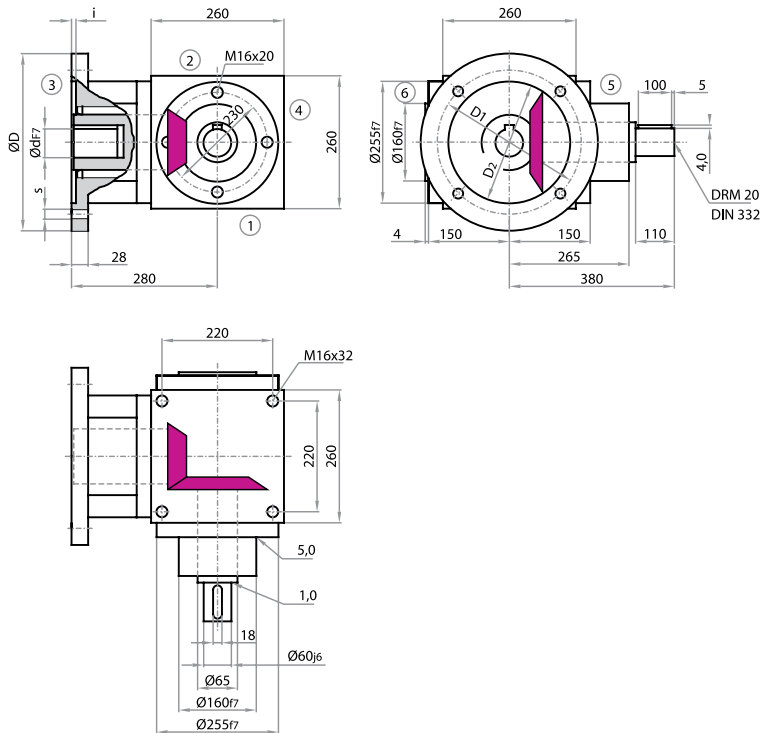

Bauart / Model

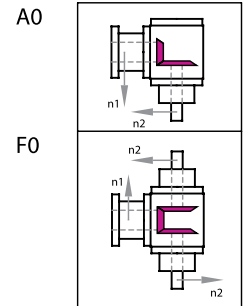

Achtung: Standardbefestigungsgewinde im Gehäuse nur an den Seiten 1, 2 & 4. Alternativ auch an den Seiten 5 & 6 möglich.
Note: Standard fastening thread in the housing only on sides 1, 2 & 4. Alternatively, also possible on sides 5 & 6.

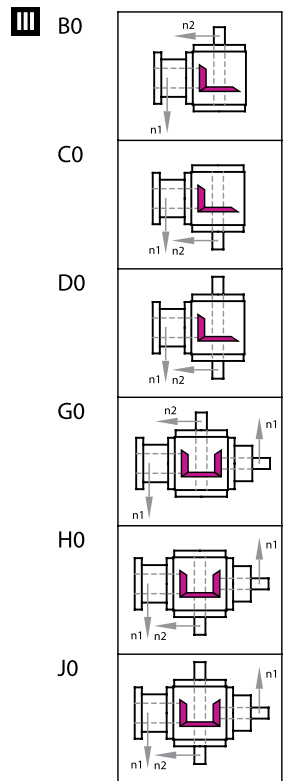
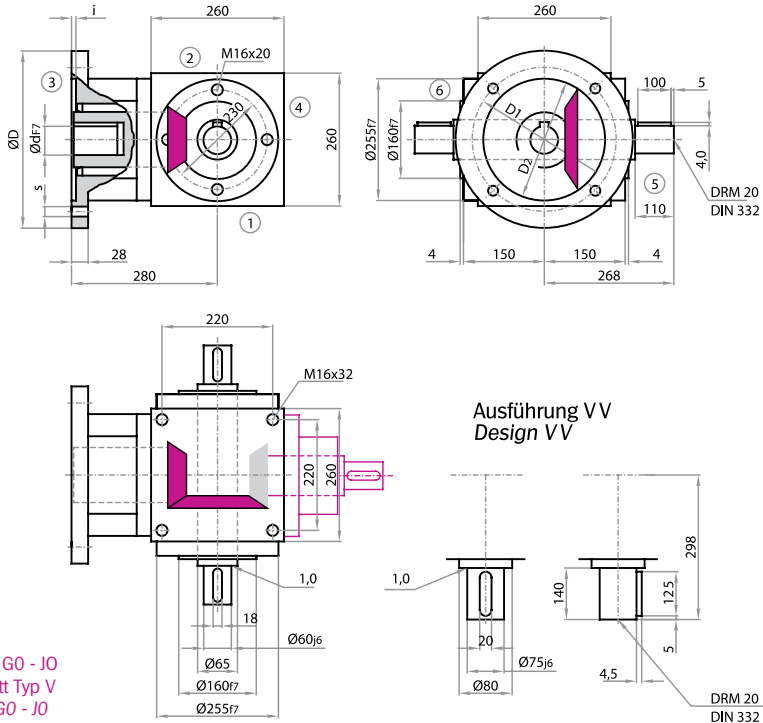

Zusatzflansch für Bauart G0 - J0
 Abmessungen siehe Maßblatt Typ V
 Additional flange for model G0 - J0
 For measurements refer to type V

Achtung: Standardbefestigungsgewinde im Gehäuse nur an den Seiten 1, 2 & 4. Alternativ auch an den Seiten 5 & 6 möglich.
Note: Standard fastening thread in the housing only on sides 1, 2 & 4. Alternatively, also possible on sides 5 & 6.

Abmessungen / Measurements

Flanschabmessungen / flange measurements				
D	D1	D2	s	i
300	265	230	14	5
350	300	250	18	6
400	350	300	18	6
450	400	350	18	6

passend für Motoranbau / fitted for motor attachment			
Baugröße / Size	D	Bauform / Design	Welle / shaft d
132	300	B 5	38 x 80
160	350	B 5	42 x 80/110
180	350	B 5	48 x 80/110
200	400	B 5	55 x 110

IV Leistungen, Drehmomente / Power Ratings, Torque Ratings

[n = min-1, P = kW, T = Nm]

i =	1:1	P1N	1,5:1	P1N	2:1	P1N	3:1	P1N	4:1	P1N	5:1	P1N	6:1	P1N
n1	n2	T2N	n2	T2N	n2	T2N	n2	T2N	n2	T2N	n2	T2N	n2	T2N
3000	3000		2000	189,58	1500	133,92	1000	85,97	750	57,87	600	46,29	500	27,27
				860,00		810,00		780,00		700,00		700,00		495,00
2400	2400		1600	158,72	1200	112,43	800	72,39	600	51,58	480	40,21	400	23,12
				900,00		850,00		821,00		780,00		760,00		524,00
1500	1500	157,07	1000	104,71	750	78,53	500	49,60	375	37,20	300	29,10	250	16,36
		950,00		950,00		950,00		900,00		900,00		880,00		594,00
1000	1000	115,73	667	73,50	500	57,87	333	36,34	250	28,93	200	21,82	167	12,93
		1050,00		1000,00		1050,00		990,00		1050,00		990,00		702,00
750	750	96,72	500	55,11	375	48,36	250	28,93	187,5	22,73	150	18,19	125	10,91
		1170,00		1000,00		1170,00		1050,00		1100,00		1100,00		792,00
500	500	72,75	333	36,70	250	33,07	167	20,43	125	16,26	100	13,23	83	8,06
		1320,00		1000,00		1200,00		1110,00		1180,00		1200,00		878,00
250	250	42,44	167	18,40	125	16,53	83	11,16	62,5	8,61	50	7,11	42	4,35
		1540,00		1000,00		1200,00		1220,00		1250,00		1290,00		940,00
50	50	9,64	33	3,64	25	3,31	17	2,55	12,5	1,82	10	1,47	8,3	0,87
		1750,00		1000,00		1200,00		1360,00		1320,00		1330,00		951,00
P1Nt		42,00		42,00		42,00		42,00		42,00		42,00		42,00
T2max		2310,00		1000,00		1200,00		1940,00		1940,00		1910,00		1730,00

Radialkräfte / Radial Forces (N)

FA	FR	T2 Nm	n2 (1/min)					FA	FR	T2 Nm	n2 (1/min)				
			3000	1000	500	250	100				50	3000	1000	500	250
<	950	7000	8600	11200	15000	17500	20000			8500	13000	16000	18000	22000	28000
>	950	5830	7170	9330	12500	14580	16670			7080	10830	13330	15000	18330	23330

Weitere Erläuterungen und verstärkte Lagerungen siehe Allgemeines / For more information and reinforced bearings, refer to general information.
 Axialkräfte FA = 50% der Radialkräfte - siehe Allgemeines / Axial forces FA = 50% of radial forces - refer to general information.

Massenträgheitsmomente / Moments of Inertia J (kgcm²)

reduziert auf die Antriebswelle (n1) / reduced to the input shaft (n1)

Bauart Model	Übersetzung / Transmission Ratios						
	1:1	1,5:1	2:1	3:1	4:1	5:1	6:1
A0	826,1000	347,1833	202,6750	136,3733	115,8038	105,5340	100,5583
F0	1233,2000	528,1167	304,4500	181,6067	141,2475	121,8180	111,8667
B0, C0	839,3400	209,5122	289,7350	168,5111	135,6938	118,2636	109,4539
D0	853,7500	424,8056	293,3375	103,5567	136,5944	118,8400	109,8542
G0, H0	1246,4400	334,5122	382,2350	208,3611	157,0238	139,2636	129,9539
J0	1260,8500	549,8056	385,8375	143,4067	157,9244	139,8400	130,3542

Getriebegewichte

Gearbox Weights (kg)

Bauart Model	ca. Gewicht app. Weight
A0	100
F0	120
B0, C0	100
D0	103
G0, H0	124
J0	127

Abzug für Motorwellenbohrung / Reduction for motor shaft bore

Ø d x l	38x80 = -1,3659	42x80 = -2,0384	48x80 = 3,4774	48x110 = 4,7047	55x110 = 8,1099
---------	-----------------	-----------------	----------------	-----------------	-----------------

V Befestigungsseite / Mounting Side

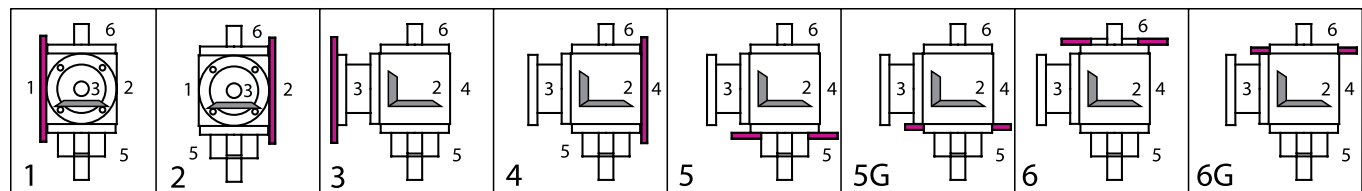

VI Einbautagen (unten liegende Getriebeseite) / Mounting Configuration (downward-facing side)

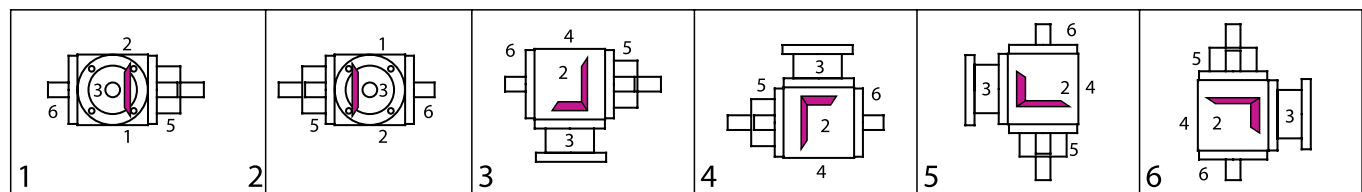

Bestellbeispiel / Example of Order

I Typ	Größe Size	IV Übersetzung Ratio	III Bauart Model	V Befestigungs- Mounting Side	VI Einbautage Mounting Config.	IV Drehzahl n2max Speed	Ausführung Design
VL	260	5:1	A0	1	1	200 / 0000=Standard	
II ø Flansch ø Flange	D 300	II Welle (ø x Länge) Shaft (ø x length)	/ 38 x 80				

Kegelradgetriebe Typ V
Bevel Gearboxes Type V

IV Leistungen, Drehmomente / Power Ratings, Torque Ratings

[n=min-1, P=kW, T=Nm]

i =	1:1	P1N	1,5:1	P1N	2:1	P1N	3:1	P1N	4:1	P1N	5:1	P1N	6:1	P1N
n1	n2	T2N	n2	T2N	n2	T2N	n2	T2N	n2	T2N	n2	T2N	n2	T2N
3000	3000		2000	189,58	1500	133,92	1000	85,97	750	57,87	600	46,29	500	27,27
				860,00		810,00		780,00		700,00		700,00		495,00
2400	2400		1600	158,72	1200	112,43	800	72,39	600	51,58	480	40,21	400	23,12
				900,00		850,00		821,00		780,00		760,00		524,00
1500	1500	157,07	1000	104,71	750	78,53	500	49,60	375	37,20	300	29,10	250	16,36
		950,00		950,00		950,00		900,00		900,00		880,00		594,00
1000	1000	115,73	667	73,50	500	57,87	333	36,34	250	28,93	200	21,82	167	12,93
		1050,00		1000,00		1050,00		990,00		1050,00		990,00		702,00
750	750	96,72	500	55,11	375	48,36	250	28,93	187,5	22,73	150	18,19	125	10,91
		1170,00		1000,00		1170,00		1050,00		1100,00		1100,00		792,00
500	500	72,75	333	36,70	250	33,07	167	20,43	125	16,26	100	13,23	83	8,06
		1320,00		1000,00		1200,00		1110,00		1180,00		1200,00		878,00
250	250	42,44	167	18,40	125	16,53	83	11,16	62,5	8,61	50	7,11	42	4,35
		1540,00		1000,00		1200,00		1220,00		1250,00		1290,00		940,00
50	50	9,64	33	3,64	25	3,31	17	2,55	12,5	1,82	10	1,47	8,3	0,87
		1750,00		1000,00		1200,00		1360,00		1320,00		1330,00		951,00
P1Nt		42,00		42,00		42,00		42,00		42,00		42,00		42,00
T2max		2310,00		1000,00		1200,00		1940,00		1940,00		1910,00		1730,00

Radialkräfte / Radial Forces (N)

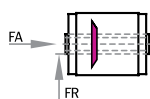

T2	n2 (1/min)					
Nm	3000	1000	500	250	100	50
< 950	8500	13000	16000	18000	22000	28000
> 950	7080	10830	13330	15000	18330	23330

Weitere Erläuterungen und verstärkte Lagerungen siehe Allgemeines / For more information and reinforced bearings, refer to general information.
 Axialkräfte FA = 50% der Radialkräfte - siehe Allgemeines / Axial forces FA = 50% of radial forces - refer to general information.

Massenträgheitsmomente / Moments of Inertia J (kgcm²)

reduziert auf die Antriebswelle (n1) / reduced to the input shaft (n1)

Bauart Model	Übersetzung / Transmission Ratios						
	1:1	1,5:1	2:1	3:1	4:1	5:1	6:1
E0	840,5900	454,5122	296,2975	171,4000	137,3188	119,3036	110,1761
K0	1247,6900	579,5122	388,7975	211,2500	158,6488	140,3036	130,6761
E0/HSD	904,2400	482,8011	312,2100	178,4700	141,2956	121,8488	111,9436
K0/HSD	1311,3400	607,8011	404,7100	218,3200	162,6256	142,8488	132,4436

Getriebegewichte

Gearbox Weights (kg)

Bauart Model	ca. Gewicht app. Weight
E0	97
K0	121
E0/HSD	99,9
K0/HSD	123,9

Abzug für Motorwellenbohrung / Reduction for motor shaft bore

Ø d x l	38x80 = -1,3659	42x80 = -2,0384	48x80 = 3,4774	48x110 = 4,7047	55x110 = 8,1099
---------	-----------------	-----------------	----------------	-----------------	-----------------

V Befestigungsseite / Mounting Side

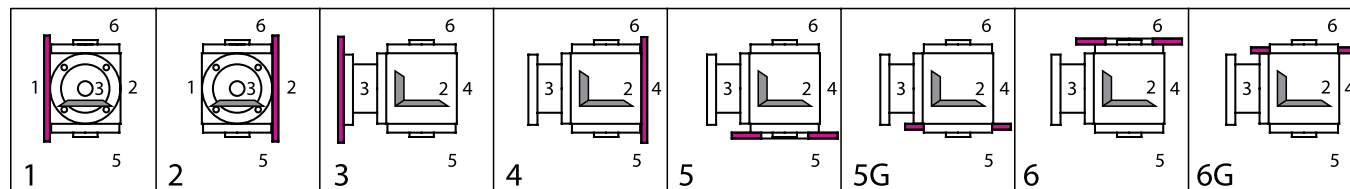

VI Einbaulagen (unten liegende Getriebeseite) / Mounting Configuration (downward-facing side)

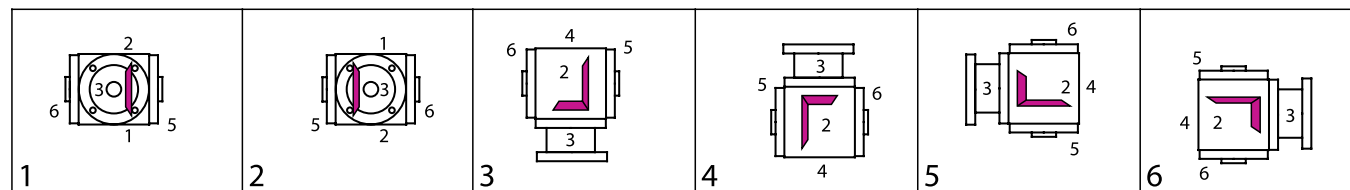

Bestellbeispiel / Example of Order

I Typ	Größe Size	IV Übersetzung Ratio	III Bauart Model	V Befestigungs- Mounting Side	VI Einbaulage Mounting Config.	IV Drehzahl n2max Speed n2max	Ausführung Design
VL	260	5:1	E0	1	1	200	0000=Standard
II	Ø Flansch Ø Flange D 300	III	Welle (Ø x Länge) Shaft (Ø x length) / 38 x 80				

Kegelradgetriebe Typ V
Bevel Gearboxes Type V

Typ VLM 065

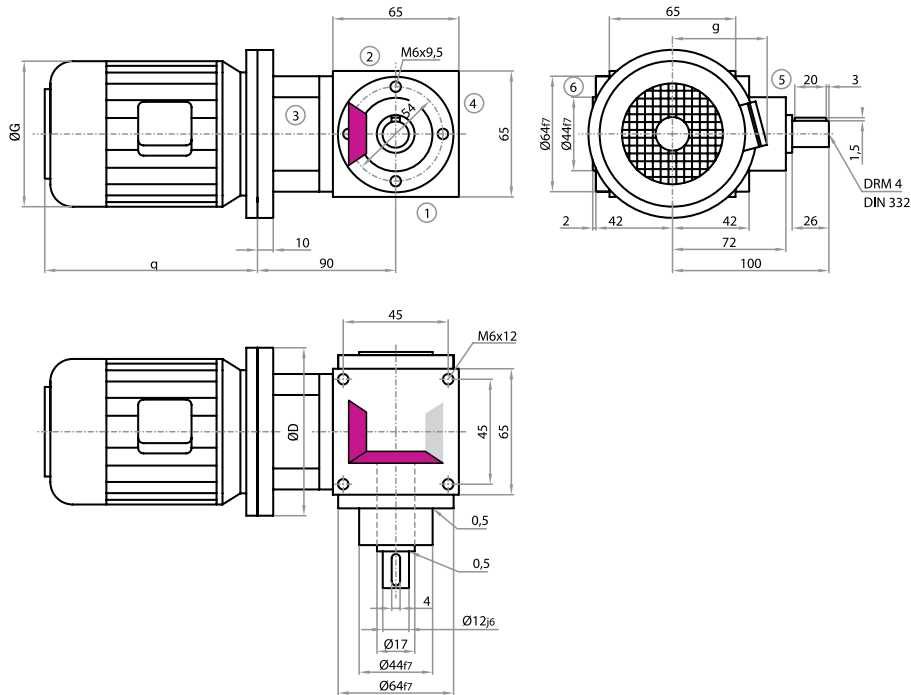

Bauart / Model

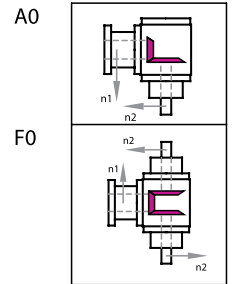

Achtung: Standardbefestigungsgewinde im Gehäuse nur an den Seiten 1, 2 & 4.
Alternativ auch an den Seiten 5 & 6 im Rastermaß 54x54 möglich.

Note: Standard fastening thread in the housing only on sides 1, 2 & 4.
Alternatively, also possible in the grid dimension of 54x54 on sides 5 & 6.

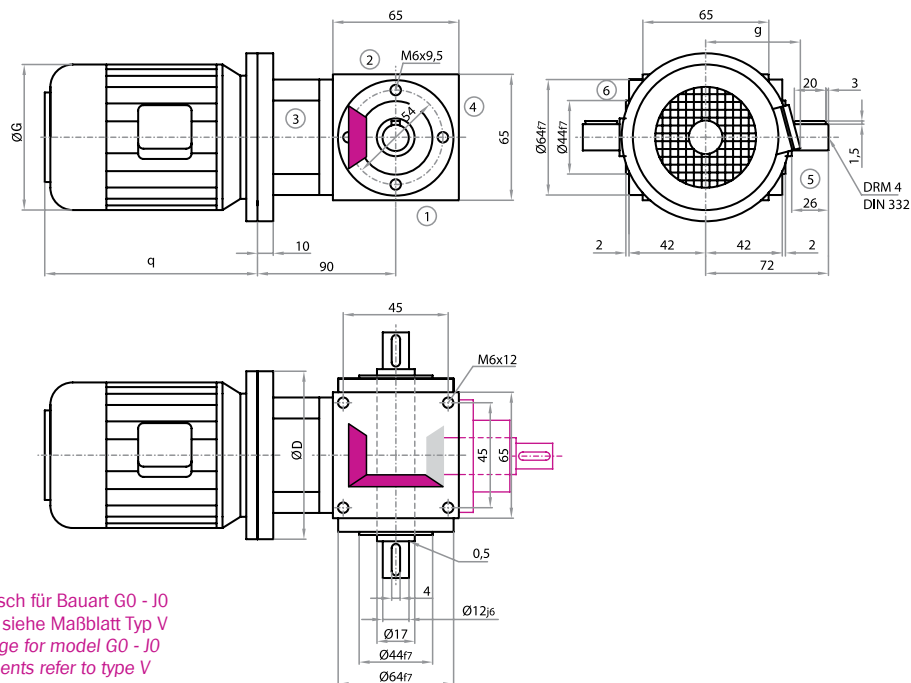

Zusatzflansch für Bauart G0 - J0
Abmessungen siehe Maßblatt Typ V
Additional flange for model G0 - J0
For measurements refer to type V

Achtung: Standardbefestigungsgewinde im Gehäuse nur an den Seiten 1, 2 & 4.
Alternativ auch an den Seiten 5 & 6 im Rastermaß 54x54 möglich.

Note: Standard fastening thread in the housing only on sides 1, 2 & 4.
Alternatively, also possible in the grid dimension of 54x54 on sides 5 & 6.

Bauart / Model

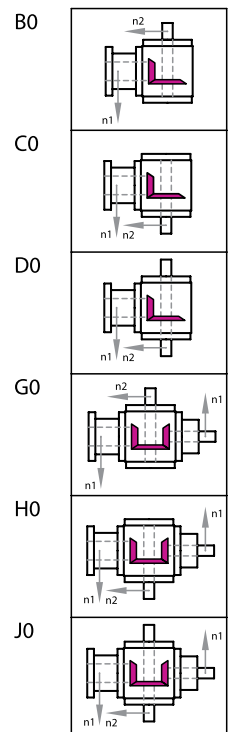

Abmessungen / Measurements

*q1=Bremmotoren / brake motors

Baugröße / Size	Motorabmessungen / Motor Dimensions				
	D	G	g	q	q1*
063	120	125	95	189	211
071	140	148	115	208	228

IV Leistungen, Drehmomente / Power Ratings, Torque Ratings

P1 kW	n2 1/min	T2 Nm	T2N Nm	T2max Nm	i	Motor
0,12	1340	0,81	11	25	1	063A-4
	893	1,22	11	25	1,5	063A-4
	670	1,62	11	25	2	063A-4
	593	1,84	13	25	1,5	063B-6
	447	2,44	11	23	3	063A-4
	445	2,45	13	25	2	063B-6
	296	3,68	12	23	3	063B-6
0,18	2680	0,61	10	25	1	063A-2
	1787	0,91	10	25	1,5	063A-2
	1340	1,22	10	25	1	063B-4
	893	1,83	10	25	1,5	063B-4
	670	2,44	10	25	2	063B-4
	593	2,75	10	25	1,5	071A-6
	450	3,63	11	23	3	063B-4
	446	3,66	11	25	3	063B-4
	445	3,67	10	25	2	071A-6
	296	5,52	11	23	3	071A-6

P1 kW	n2 1/min	T2 Nm	T2N Nm	T2max Nm	i	Motor
0,25	2700	0,84	10	25	1	063B-2
	1800	1,26	10	25	1,5	063B-2
	1350	1,68	10	25	1	071A-4
	890	2,55	10	25	1	071B-6
	675	3,36	10	25	2	071A-4
	450	5,04	11	25	3	071A-4
	445	5,1	10	25	2	071B-6
0,37	2800	1,2	10	25	1	071A-2
	1400	2,4	10	25	2	071A-2
	1350	2,49	10	25	1	071B-4
	933	3,6	10	23	3	071A-2
	675	4,97	10	25	2	071B-4
0,55	2810	1,78	10	25	1	071B-2
	1873	2,66	10	23	1,5	071B-2
	1405	3,55	10	25	2	071B-2
	936	5,33	10	23	3	071B-2

Radialkräfte / Radial Forces (N)

FA	FR	T2 Nm	n2 (1/min)					
			3000	1000	500	250	100	50
←	↑	12	180	250	300	350	450	550
→	↑	12	150	210	250	290	380	460

Weitere Erläuterungen und verstärkte Lagerungen siehe Allgemeines / For more information and reinforced bearings, refer to general Information.
 Axialkräfte FA = 50% der Radialkräfte - siehe Allgemeines / Axial forces FA = 50% of radial forces - refer to general information.

**Massenträgheitsmomente und Getriebegewichte auf Anfrage.
 Moments of Inertia and gearbox weights available on request.**

V Befestigungsseite / Mounting Side

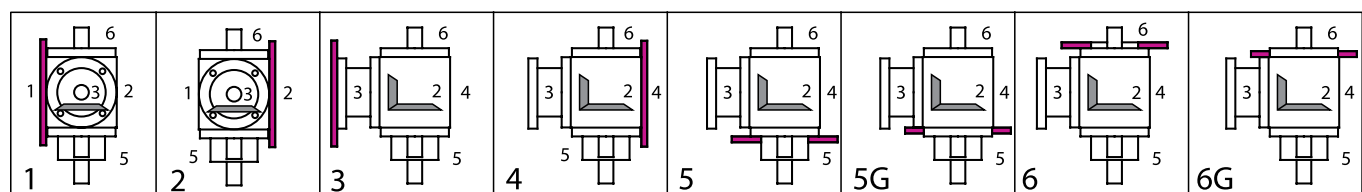

VI Einbautagen (unten liegende Getriebeseite) / Mounting Configuration (downward-facing side)

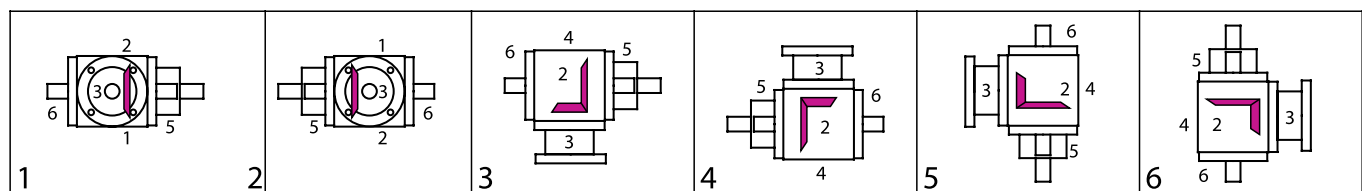

Bestellbeispiel / Example of Order

I Typ	Größe Size	IV Übersetzung Ratio	III Bauart Model	V Befestigungs- Mounting Side	VI Einbautage Mounting Config.	IV Drehzahl n2max Speed n2max	Ausführung Design
VLM	065	3:1	C0	-	1	-	500 / 0000=Standard
III Motorausführung Motor features	Polzahl No. of Poles	Zusatzausführung Additional features		Klemmenkastenlage (Getriebeseite) Position of terminal box (gear site)			
DS 063	-	4	/	00	-	5	

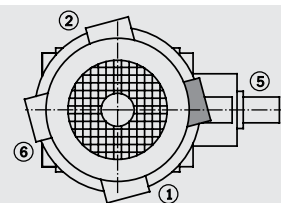

Kegelradgetriebe Typ V
Bevel Gearboxes Type V

Typ VLM 065

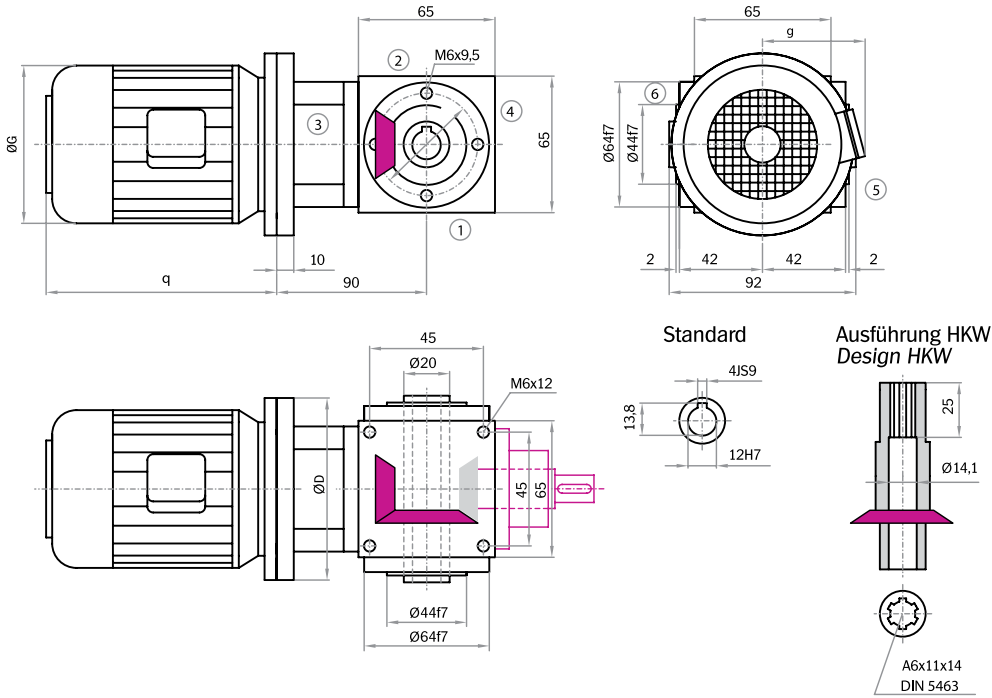

Bauart / Model

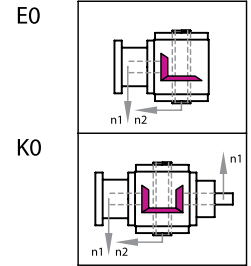

Achtung: Standardbefestigungsgewinde im Gehäuse nur an den Seiten 1, 2 & 4.
 Alternativ auch an den Seiten 5 & 6 im Rastermaß 54x54 möglich.
Note: Standard fastening thread in the housing only on sides 1, 2 & 4.
 Alternatively, also possible in the grid dimension of 54x54 on sides 5 & 6.

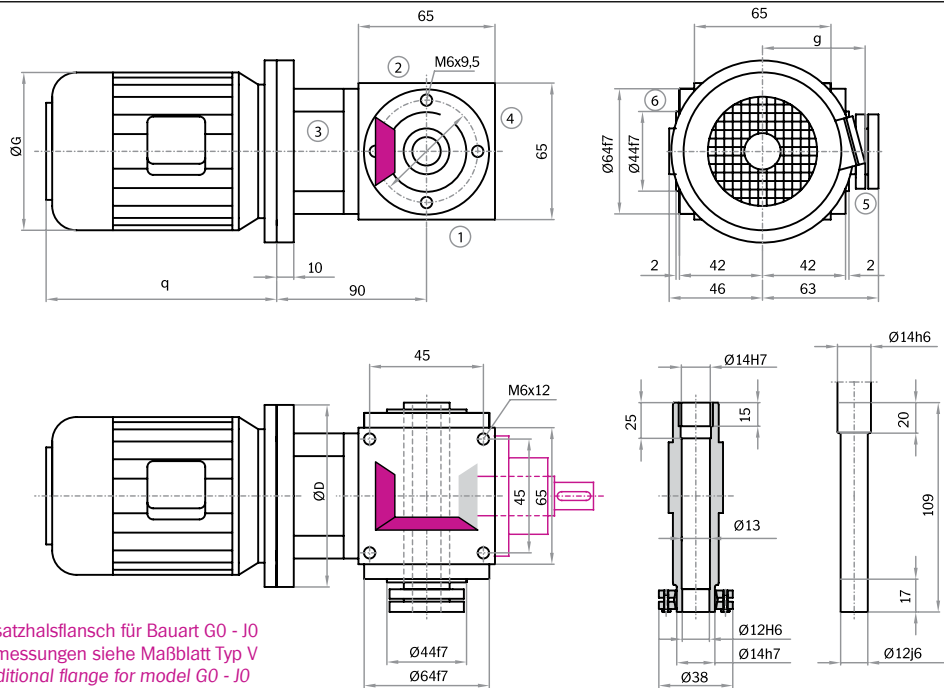

Bauart / Model

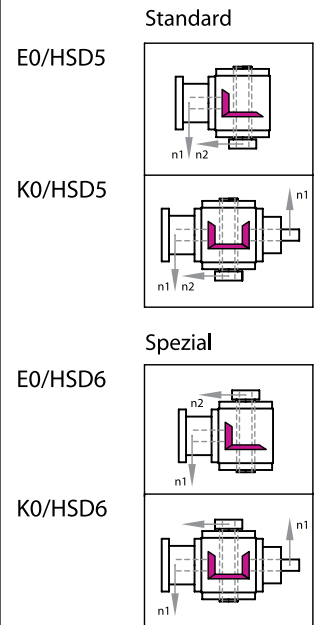

Zusatzflansch für Bauart G0 - J0
 Abmessungen siehe Maßblatt Typ V
 Additional flange for model G0 - J0
 For measurements refer to type V

Achtung: Standardbefestigungsgewinde im Gehäuse nur an den Seiten 1, 2 & 4.
 Alternativ auch an den Seiten 5 & 6 im Rastermaß 54x54 möglich.
Note: Standard fastening thread in the housing only on sides 1, 2 & 4.
 Alternatively, also possible in the grid dimension of 54x54 on sides 5 & 6.

Abmessungen / Measurements

*q1=Bremmotoren / brake motors

Baugröße / Size	Motorabmessungen / Motor Dimensions					
	D	G	g	q	q1*	
063	120	125	95	189	211	
071	140	148	115	208	228	

IV Leistungen, Drehmomente / Power Ratings, Torque Ratings

P1 kW	n2 1/min	T2 Nm	T2N Nm	T2max Nm	i	Motor
0,12	1340	0,81	11	25	1	063A-4
	893	1,22	11	25	1,5	063A-4
	670	1,62	11	25	2	063A-4
	593	1,84	13	25	1,5	063B-6
	447	2,44	11	23	3	063A-4
	445	2,45	13	25	2	063B-6
	296	3,68	12	23	3	063B-6
0,18	2680	0,61	10	25	1	063A-2
	1787	0,91	10	25	1,5	063A-2
	1340	1,22	10	25	1	063B-4
	893	1,83	10	25	1,5	063B-4
	670	2,44	10	25	2	063B-4
	593	2,75	10	25	1,5	071A-6
	450	3,63	11	23	3	063B-4
	446	3,66	11	25	3	063B-4
	445	3,67	10	25	2	071A-6
	296	5,52	11	23	3	071A-6

P1 kW	n2 1/min	T2 Nm	T2N Nm	T2max Nm	i	Motor
0,25	2700	0,84	10	25	1	063B-2
	1800	1,26	10	25	1,5	063B-2
	1350	1,68	10	25	1	071A-4
	890	2,55	10	25	1	071B-6
	675	3,36	10	25	2	071A-4
	450	5,04	11	25	3	071A-4
	445	5,1	10	25	2	071B-6
0,37	2800	1,2	10	25	1	071A-2
	1400	2,4	10	25	2	071A-2
	1350	2,49	10	25	1	071B-4
	933	3,6	10	23	3	071A-2
	675	4,97	10	25	2	071B-4
	0,55	2810	1,78	10	25	1
1873		2,66	10	23	1,5	071B-2
1405		3,55	10	25	2	071B-2
936		5,33	10	23	3	071B-2

Radialkräfte / Radial Forces (N)

FA	FR	T2 Nm	n2 (1/min)						FA	FR	T2 Nm	n2 (1/min)					
			3000	1000	500	250	100	50				3000	1000	500	250	100	50
<		12	180	250	300	350	450	550			300	400	500	650	750	900	
>		12	150	210	250	290	380	460			250	330	420	540	630	750	

Weitere Erläuterungen und verstärkte Lagerungen siehe Allgemeines / For more information and reinforced bearings, refer to general Information.
 Axialkräfte FA = 50% der Radialkräfte - siehe Allgemeines / Axial forces FA = 50% of radial forces - refer to general information.

**Massenträgheitsmomente und Getriebegewichte auf Anfrage.
 Moments of Inertia and gearbox weights available on request.**

V Befestigungsseite / Mounting Side

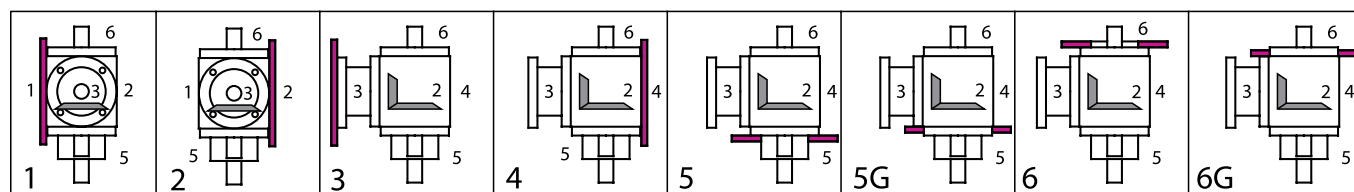

VI Einbautagen (unten liegende Getriebeseite) / Mounting Configuration (downward-facing side)

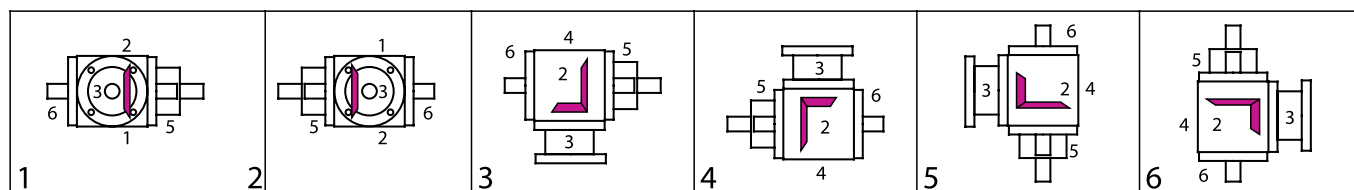

Bestellbeispiel / Example of Order

I Typ	Größe Size	IV Übersetzung Ratio	III Bauart Model	V Befestigungs- Mounting Side	VI Einbautage Mounting Config.	IV Drehzahl n2max Speed n2max	Ausführung Design
VLM	065	3:1	E0	-	1	-	500 / 0000=Standard
III Motorausführung Motor features	Polzahl No. of Poles	Zusatzausführung Additional features	Klemmenkastenlage (Getriebeseite) Position of terminal box (gear site)				
DS 063	-	4	/	00	-		5

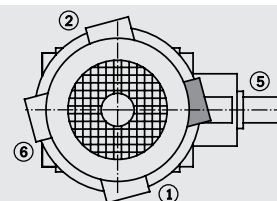

Typ VLM 090

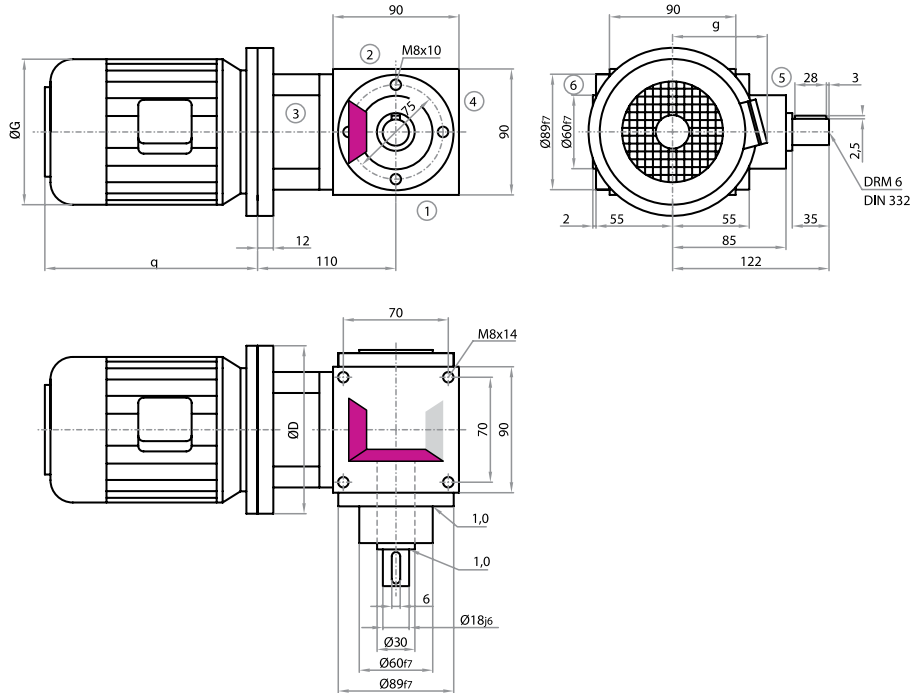

Bauart / Model

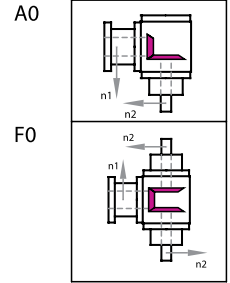

Achtung: Standardbefestigungsgewinde im Gehäuse nur an den Seiten 1, 2 & 4.
Alternativ auch an den Seiten 5 & 6 im Rastermaß 75x75 möglich.

Note: Standard fastening thread in the housing only on sides 1, 2 & 4.
Alternatively, also possible in the grid dimension of 75x75 on sides 5 & 6.

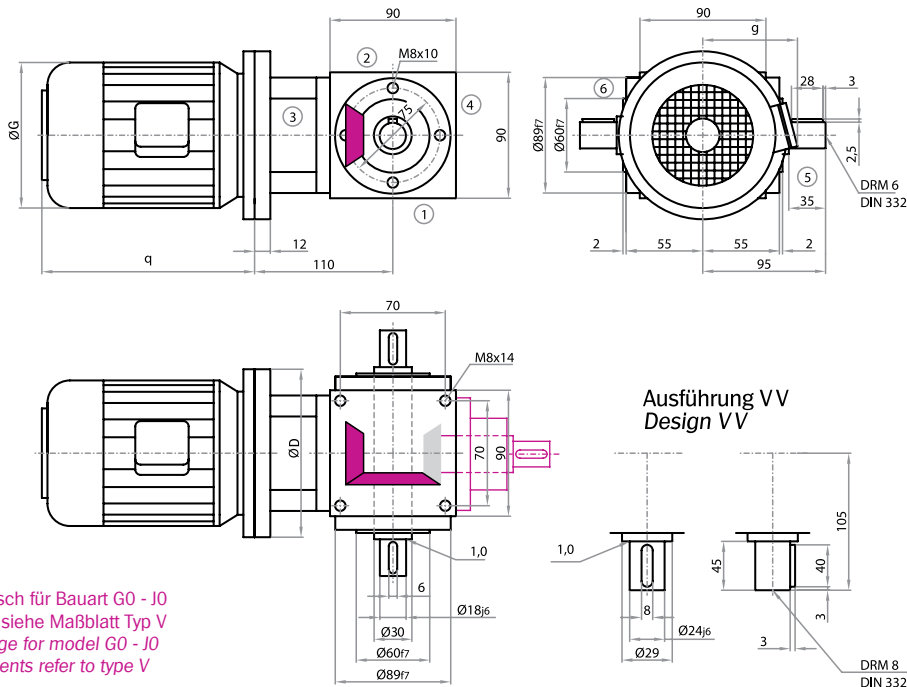

Zusatzflansch für Bauart G0 - J0
Abmessungen siehe Maßblatt Typ V
Additional flange for model G0 - J0
For measurements refer to type V

Achtung: Standardbefestigungsgewinde im Gehäuse nur an den Seiten 1, 2 & 4.
Alternativ auch an den Seiten 5 & 6 im Rastermaß 75x75 möglich.

Note: Standard fastening thread in the housing only on sides 1, 2 & 4.
Alternatively, also possible in the grid dimension of 75x75 on sides 5 & 6.

B0

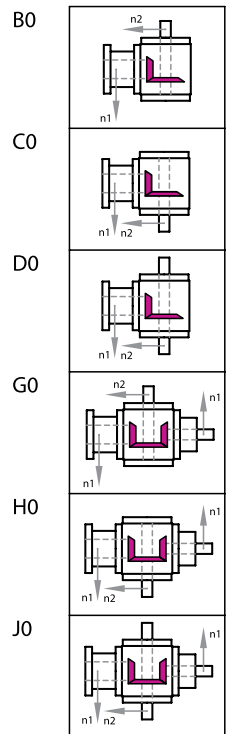

Abmessungen / Measurements

*q1=Bremmotoren / brake motors

Baugröße / Size	Motorabmessungen / Motor Dimensions					q1*
	D	G	g	q		
063	120	125	95	189	211	
071	140	148	115	208	228	
080	120	170	126	234	245	

IV Leistungen, Drehmomente / Power Ratings, Torque Ratings

P1 kW	n2 1/min	T2 Nm	T2N Nm	T2max Nm	i	Motor	P1 kW	n2 1/min	T2 Nm	T2N Nm	T2max Nm	i	Motor	P1 kW	n2 1/min	T2 Nm	T2N Nm	T2max Nm	i	Motor	
0,18	335	4,87	27	70	4	063B-4	0,37	1866	1,80	25	40	1,5	071A-2	0,55	453	11,01	27	70	3	080A-4	
	296	5,50	31	70	3	071A-6		933	3,60	23	70	3	071A-2		340	14,68	27	70	4	080A-4	
	268	6,09	27	60	5	063B-4		900	3,73	29	40	1,5	071B-4		300	16,63	31	70	3	080B-6	
	224	7,29	25	50	6	063B-4		700	4,80	23	70	4	071A-2		227	21,98	25	50	6	080A-4	
	222	7,34	31	70	4	071A-6		675	4,97	27	30	2	071B-4		225	22,18	31	70	4	080B-6	
	178	9,17	31	60	5	071A-6		600	5,59	32	40	1,5	080A-6		180	27,72	31	60	5	080B-6	
	167	9,75	32	70	4	080A-8		560	5,99	23	60	5	071A-2		0,75	2820	2,41	27	105	1	080A-2
	148	11,03	29	50	6	071A-6		450	7,46	27	70	3	071B-4			1880	3,62	25	40	1,5	080A-2
	134	12,19	32	60	5	080A-8		337	9,95	27	70	4	071B-4			1410	4,83	23	30	2	080A-2
	112	14,58	30	50	6	080A-8		300	11,19	31	70	3	080A-6			1360	5,00	32	105	1	080B-4
0,25	900	2,52	29	40	1,5	071A-4	270	12,43	27	60	5	071B-4	940	7,24		23	70	3	080A-2		
	593	3,82	32	40	1,5	071B-6	225	14,92	25	50	6	071B-4	906	7,50		29	40	1,5	080B-4		
	540	4,20	23	60	5	063B-2	180	18,65	31	60	5	080A-6	705	9,65		23	70	4	080A-2		
	450	5,04	27	70	3	071A-4	150	22,38	29	50	6	080A-6	680	10,01		27	30	2	080B-4		
	337	6,72	27	70	4	071A-4	0,55	1873	2,66	25	40	1,5	071B-2	564		12,06	27	60	5	080A-2	
	296	7,65	31	70	3	071B-6		1360	3,67	32	105	1	080A-4	453		15,01	27	70	3	080B-4	
	270	8,40	27	60	5	071A-4		936	5,33	23	70	3	071B-2	340	20,01	27	70	4	080B-4		
	225	10,08	25	50	6	071A-4		906	5,50	29	40	1,5	080A-4	1,1	2820	3,54	27	105	1	080B-2	
	178	12,74	31	60	5	071B-6		702	7,10	23	70	4	071B-2		1880	5,31	25	40	1,5	080B-2	
	148	15,33	29	50	6	071B-6		680	7,34	27	30	2	080A-4		1410	7,08	23	30	2	080B-2	
134	16,93	32	60	5	080B-8	600		8,32	32	40	1,5	080B-6	940		10,62	23	70	3	080B-2		
112	20,25	30	50	6	080B-8	562		8,88	23	60	5	071B-2	705		14,16	23	70	4	080B-2		

Radialkräfte / Radial Forces (N)

FA	FR	T2 Nm	n2 (1/min)						FA	FR	n2 (1/min)					
			3000	1000	500	250	100	50			3000	1000	500	250	100	50
<	30	300	400	470	580	700	800	<	30	300	400	470	580	700	800	
>	30	250	330	390	490	590	670	>	30	250	330	390	490	590	670	

Weitere Erläuterungen und verstärkte Lagerungen siehe Allgemeines / For more information and reinforced bearings, refer to general information.
 Axialkräfte FA = 50% der Radialkräfte - siehe Allgemeines / Axial forces FA = 50% of radial forces - refer to general information.

Massenträgheitsmomente und Getriebegewichte auf Anfrage. Moments of Inertia and gearbox weights available on request.

V Befestigungsseite / Mounting Side

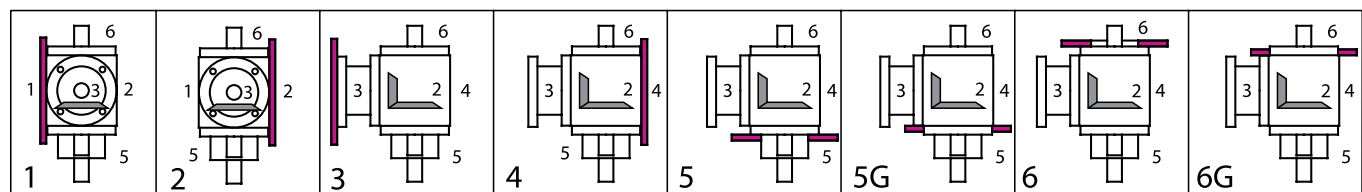

VI Einbautagen (unten liegende Getriebeseite) / Mounting Configuration (downward-facing side)

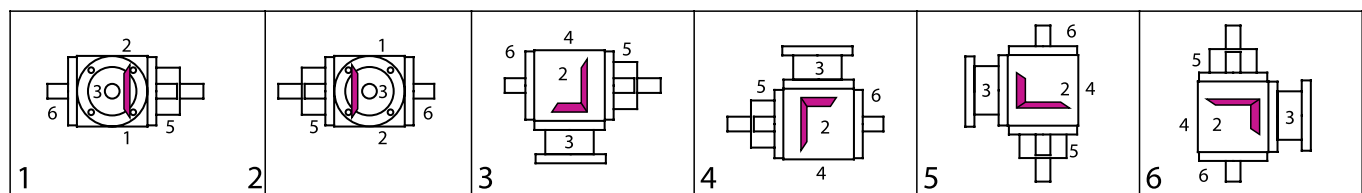

Bestellbeispiel / Example of Order

I Typ	Größe	IV Übersetzung	III Bauart	V Befestigungs.	VI Einbautage	IV Drehzahl n2max	Ausführung
VLM	090	3:1	A0	-	1	-	500 / 0000=Standard
II Motorausführung	Polzahl		Zusatzausführung		Klemmenkastenlage (Getriebeseite)		
Motor features	No. of Poles		Additional features		Position of terminal box (gear site)		
DS 071 A	4		/ 00		5		

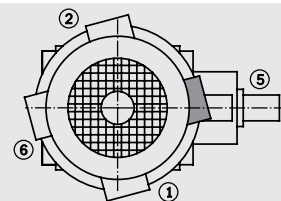

Kegelradgetriebe Typ V
Bevel Gearboxes Type V

Typ VLM 090

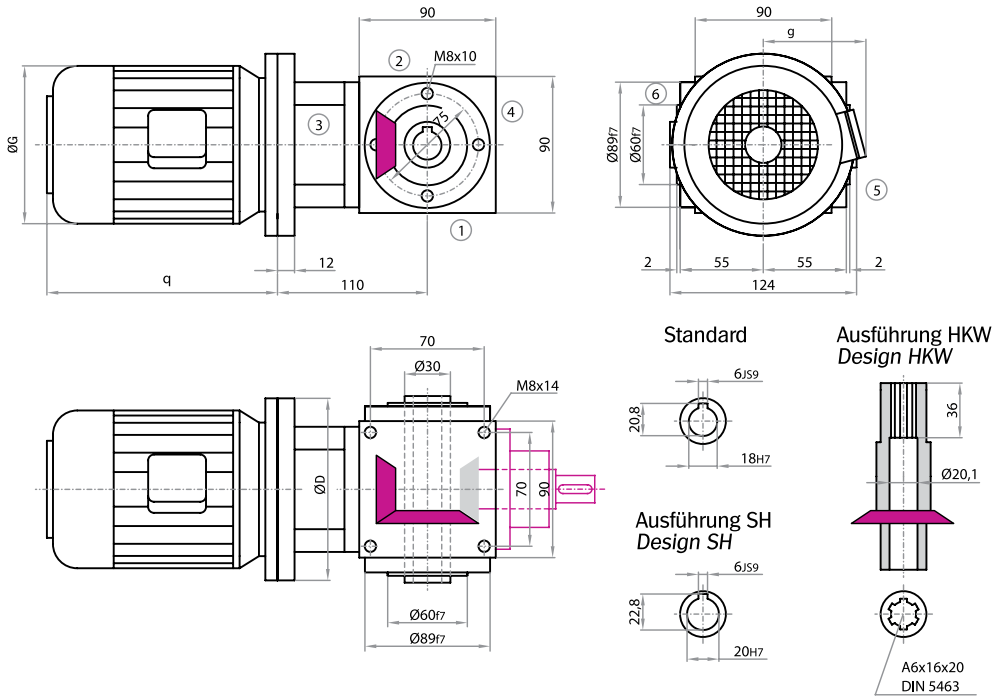

Achtung: Standardbefestigungsgewinde im Gehäuse nur an den Seiten 1, 2 & 4.
 Alternativ auch an den Seiten 5 & 6 im Rastermaß 75x75 möglich.
Note: Standard fastening thread in the housing only on sides 1, 2 & 4.
 Alternatively, also possible in the grid dimension of 75x75 on sides 5 & 6.

Bauart / Model

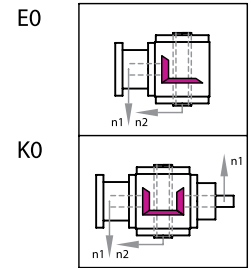

Bauart / Model

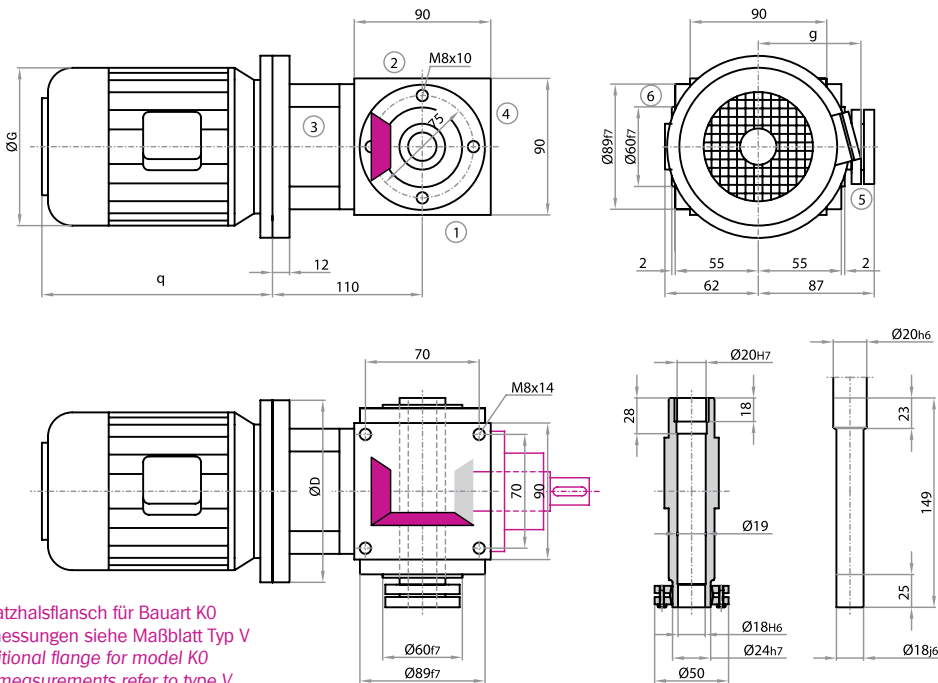

Zusatzflansch für Bauart K0
 Abmessungen siehe Maßblatt Typ V
 Additional flange for model K0
 For measurements refer to type V

Achtung: Standardbefestigungsgewinde im Gehäuse nur an den Seiten 1, 2 & 4.
 Alternativ auch an den Seiten 5 & 6 im Rastermaß 75x75 möglich.
Note: Standard fastening thread in the housing only on sides 1, 2 & 4.
 Alternatively, also possible in the grid dimension of 75x75 on sides 5 & 6.

Bauart / Model

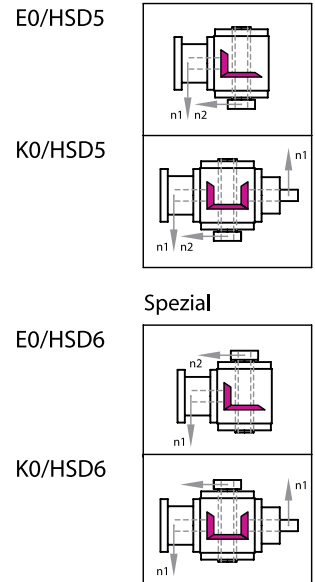

Abmessungen / Measurements

*q1=Bremmotoren / brake motors

Baugröße / size	Motorabmessungen / Motor Dimensions					
	D	G	g	q	q1*	
063	120	125	95	189	211	
071	140	148	115	208	228	
080	120	170	126	234	245	

IV Leistungen, Drehmomente / Power Ratings, Torque Ratings

P1 kW	n2 1/min	T2 Nm	T2N Nm	T2max Nm	i	Motor	P1 kW	n2 1/min	T2 Nm	T2N Nm	T2max Nm	i	Motor	P1 kW	n2 1/min	T2 Nm	T2N Nm	T2max Nm	i	Motor	
0,18	335	4,87	27	70	4	063B-4	0,37	1866	1,80	25	40	1,5	071A-2	0,55	453	11,01	27	70	3	080A-4	
	296	5,50	31	70	3	071A-6		933	3,60	23	70	3	071A-2		340	14,68	27	70	4	080A-4	
	268	6,09	27	60	5	063B-4		900	3,73	29	40	1,5	071B-4		300	16,63	31	70	3	080B-6	
	224	7,29	25	50	6	063B-4		700	4,80	23	70	4	071A-2		227	21,98	25	50	6	080A-4	
	222	7,34	31	70	4	071A-6		675	4,97	27	30	2	071B-4		225	22,18	31	70	4	080B-6	
	178	9,17	31	60	5	071A-6		600	5,59	32	40	1,5	080A-6		180	27,72	31	60	5	080B-6	
	167	9,75	32	70	4	080A-8		560	5,99	23	60	5	071A-2		0,75	2820	2,41	27	105	1	080A-2
	148	11,03	29	50	6	071A-6		450	7,46	27	70	3	071B-4			1880	3,62	25	40	1,5	080A-2
	134	12,19	32	60	5	080A-8		337	9,95	27	70	4	071B-4			1410	4,83	23	30	2	080A-2
	112	14,58	30	50	6	080A-8		300	11,19	31	70	3	080A-6			1360	5,00	32	105	1	080B-4
	0,25	900	2,52	29	40	1,5		071A-4	270	12,43	27	60	5			071B-4	940	7,24	23	70	3
593		3,82	32	40	1,5	071B-6	225	14,92	25	50	6	071B-4	906	7,50		29	40	1,5	080B-4		
540		4,20	23	60	5	063B-2	180	18,65	31	60	5	080A-6	705	9,65		23	70	4	080A-2		
450		5,04	27	70	3	071A-4	150	22,38	29	50	6	080A-6	680	10,01		27	30	2	080B-4		
337		6,72	27	70	4	071A-4	0,55	1873	2,66	25	40	1,5	071B-2	564		12,06	27	60	5	080A-2	
296		7,65	31	70	3	071B-6		1360	3,67	32	105	1	080A-4	453		15,01	27	70	3	080B-4	
270		8,40	27	60	5	071A-4		936	5,33	23	70	3	071B-2	340		20,01	27	70	4	080B-4	
225		10,08	25	50	6	071A-4		906	5,50	29	40	1,5	080A-4	1,1	2820	3,54	27	105	1	080B-2	
178		12,74	31	60	5	071B-6		702	7,10	23	70	4	071B-2		1880	5,31	25	40	1,5	080B-2	
148		15,33	29	50	6	071B-6		680	7,34	27	30	2	080A-4		1410	7,08	23	30	2	080B-2	
134		16,93	32	60	5	080B-8		600	8,32	32	40	1,5	080B-6		940	10,62	23	70	3	080B-2	
112	20,25	30	50	6	080B-8	562		8,88	23	60	5	071B-2	705		14,16	23	70	4	080B-2		

Radialkräfte / Radial Forces (N)

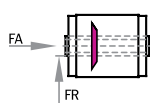

T2 Nm	3000	1000	n2 (1/min) 500	250	100	50
< 30	500	660	800	950	1250	1500
> 30	420	550	670	790	1040	1250

Weitere Erläuterungen und verstärkte Lagerungen siehe Allgemeines / For more information and reinforced bearings, refer to general information.
 Axialkräfte FA = 50% der Radialkräfte - siehe Allgemeines / Axial forces FA = 50% of radial forces - refer to general information.

Massenträgheitsmomente und Getriebegewichte auf Anfrage. Moments of Inertia and gearbox weights available on request.

V Befestigungsseite / Mounting Side

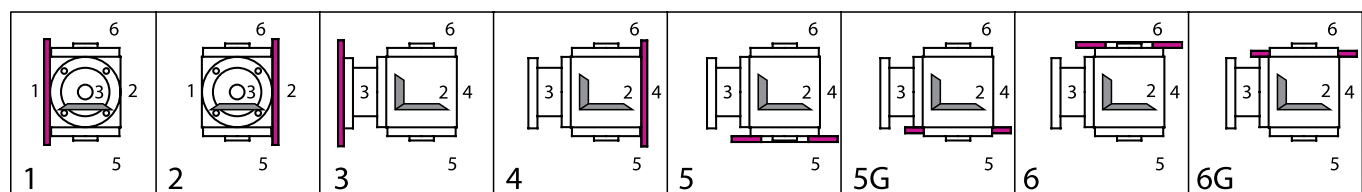

VI Einbaulagen (unten liegende Getriebeseite) / Mounting Configuration (downward-facing side)

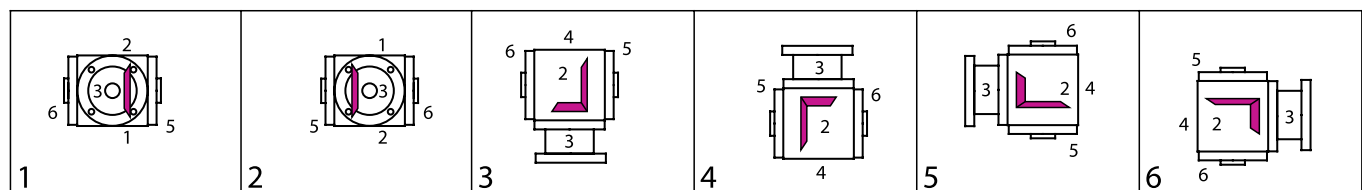

Bestellbeispiel / Example of Order

I Typ	Größe Size	IV Übersetzung Ratio	III Bauart Model	V Befestigungs- Mounting Side	VI Einbaulage Mounting Config.	IV Drehzahl n2max Speed n2max	Ausführung Design
VLM	090	3:1	E0	-	1	-	500 / 0000=Standard
III Motorausführung Motor features	Polzahl No. of Poles		Zusatzausführung Additional features		Klemmenkastenlage (Getriebeseite) Position of terminal box (gear site)		
DS 071 A	-	4	/	00	-	5	

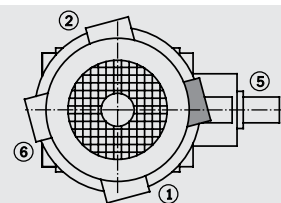

Kegelradgetriebe Typ V
Bevel Gearboxes Type V

Typ VLM 120

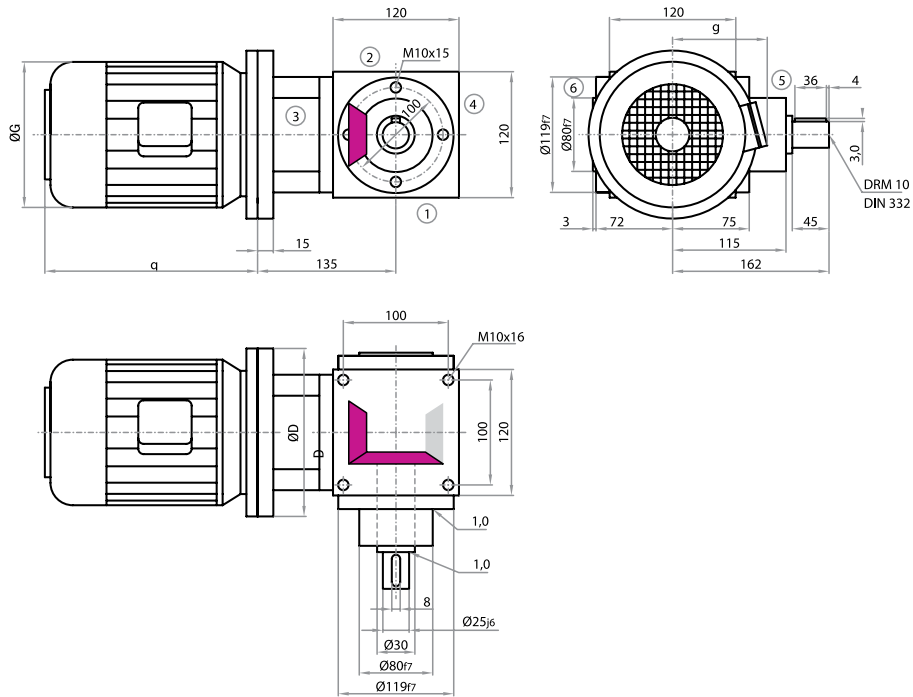

Achtung: Standardbefestigungsgewinde im Gehäuse nur an den Seiten 1, 2 & 4. Alternativ auch an den Seiten 5 & 6 möglich.
Note: Standard fastening thread in the housing only on sides 1, 2 & 4. Alternatively, also possible on sides 5 & 6.

Bauart / Model

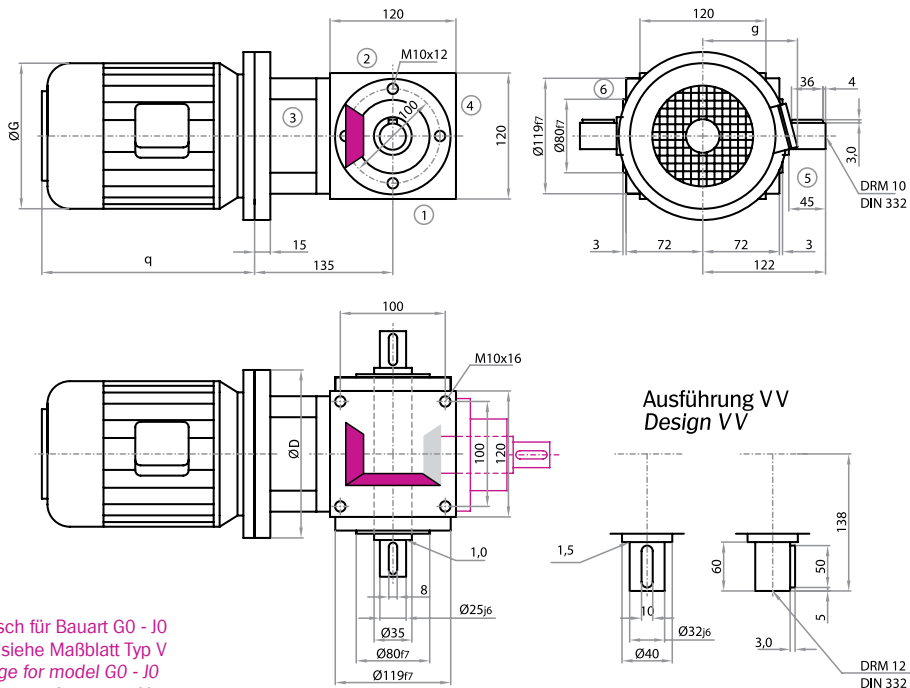
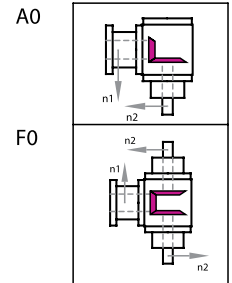

Zusatzhalsflansch für Bauart G0 - J0
 Abmessungen siehe Maßblatt Typ V
 Additional flange for model G0 - J0
 For measurements refer to type V

Achtung: Standardbefestigungsgewinde im Gehäuse nur an den Seiten 1, 2 & 4. Alternativ auch an den Seiten 5 & 6 möglich.
Note: Standard fastening thread in the housing only on sides 1, 2 & 4. Alternatively, also possible on sides 5 & 6.

Bauart / Model

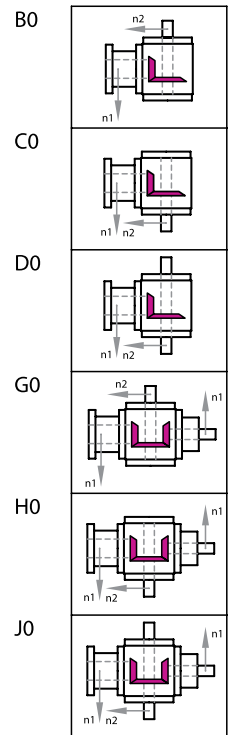

Abmessungen / Measurements

*q1=Bremmotoren / brake motors

Baugröße / Size	Motorabmessungen / Motor Dimensions				
	D	G	g	q	q1*
080	160	170	126	234	245
090S	160	185	142	247	273
090L	160	185	142	272	298
100/112	200	210	155	301	348

IV Leistungen, Drehmomente / Power Ratings, Torque Ratings

P1 kW	n2 1/min	T2 Nm	T2N Nm	T2max Nm	i	Motor	P1 kW	n2 1/min	T2 Nm	T2N Nm	T2max Nm	i	Motor	P1 kW	n2 1/min	T2 Nm	T2N Nm	T2max Nm	i	Motor			
0,55	272	18,35	72	140	5	080A-4	1,1	227	43,87	79	155	4	090L-6	2,2	1893	10,54	61	100	1,5	090L-2			
	172	28,93	82	155	4	090L-8		182	54,83	80	140	5	090L-6		1420	14,06	56	80	2	090L-2			
	150	33,27	67	120	6	080B-6		172	57,85	82	155	4			946	21,08	58	155	3	090L-2			
	138	36,16	86	140	5	090L-8		152	65,66	67	120	6	090L-6		940	21,23	78	100	1,5				
	115	43,39	69	120	6	090L-8		138	72,32	86	140	5			710	28,11	60	155	4	090L-2			
0,75	606	11,22	86	100	1,5	090S-6	1,5	2840	4,79	66	220	1	090S-2	3,0	2850	9,55	66	220	1	100L-2			
	303	22,43	82	155	3	090S-6		1893	7,19	61	100	1,5	090S-2		1900	14,33	61	100	1,5	100L-2			
	272	25,02	72	140	5	080B-4		1420	9,58	56	80	2	090S-2		1410	19,30	82	220	1				
	227	29,98	64	120	6	080B-4		1380	9,86	82	220	1	090L-4		940	28,95	78	100	1,5				
	182	37,39	80	140	5	090S-6		946	14,38	58	155	3	090S-2		705	38,61	73	80	2				
	152	44,77	67	113	6	090S-6		920	14,79	78	100	1,5	090L-4		570	47,75	60	140	5	100L-2			
	138	49,31	86	140	5			710	19,17	60	155	4	090S-2		1410	19,30	82	220	1				
	115	59,17	69	118	6			690	19,72	73	80	2	090L-4		940	28,95	78	100	1,5				
	1,1	1380	7,23	82	220	1		090S-4	2,2	2840	7,03	66	220		1	090L-2	4,0	2860	12,69	66	220	1	112M-2
		920	10,85	78	100	1,5		090S-4		613	22,19	78	100		1,5			1906	19,03	61	100	1,5	112M-2
690		14,46	73	80	2	090S-4	568	23,96		60	140	5	090S-2	1420	25,56	82		220	1	112M-4			
606		16,45	86	100	1,5	090L-6	460	29,58		74	155	3	090L-4	946	38,33	78		100	1,5	112M-4			
564		17,69	60	140	5	080B-2	345	39,45		74	155	4	090L-4	710	51,11	73		80	2	112M-4			
460		21,70	74	155	3	090S-4	306	44,38		82	155	3											
345		28,93	74	155	4	090S-4	276	49,31		72	140	5	090L-4										
303		32,90	82	155	3	090L-6	230	59,17		64	120	6	090L-4										
276		36,16	72	140	5	090S-4	184	73,96		80	140	5											

Radialkräfte / Radial Forces (N)

FA	FR	T2 Nm	n2 (1/min)						FA	FR	n2 (1/min)					
			3000	1000	500	250	100	50			3000	1000	500	250	100	50
<	80	470	620	720	900	1150	1400	750	1000	1250	1500	1900	2200			
>	80	390	520	600	750	960	1170	630	830	1040	1250	1580	1830			

Weitere Erläuterungen und verstärkte Lagerungen siehe Allgemeines / For more information and reinforced bearings, refer to general information.
 Axialkräfte FA = 50% der Radialkräfte - siehe Allgemeines / Axial forces FA = 50% of radial forces - refer to general information.

Massenträgheitsmomente und Getriebegewichte auf Anfrage. Moments of Inertia and gearbox weights available on request.

V Befestigungsseite / Mounting Side

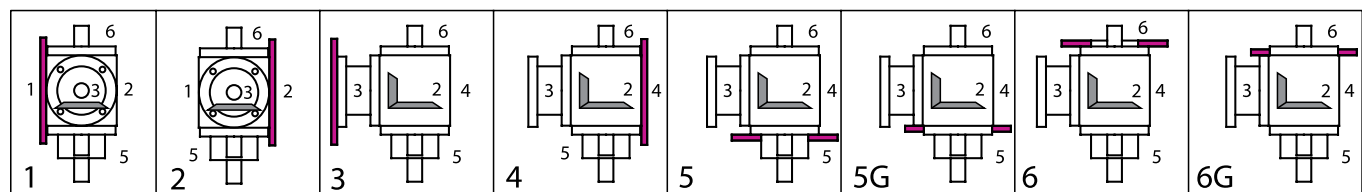

V Einbaulagen (unten liegende Getriebeseite) / Mounting Configuration (downward-facing side)

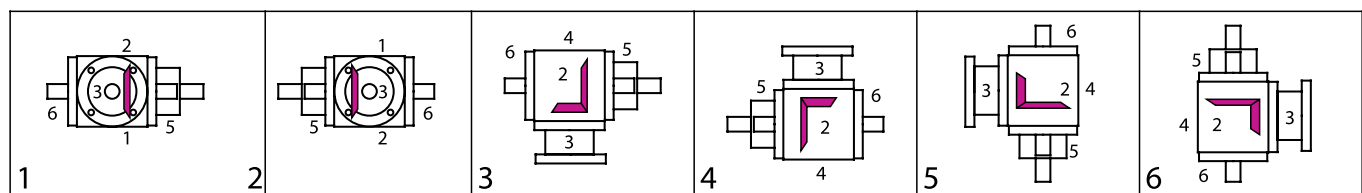

Bestellbeispiel / Example of Order

I Typ	Größe	IV Übersetzung	III Bauart	V Befestigungs.	VI Einbaulage	IV Drehzahl n2max	Ausführung
VLM	120	3:1	A0	-	1	-	500 / 0000=Standard
II Motorausführung	Polzahl		Zusatzausführung		Klemmenkastenlage (Getriebeseite)		
Motor features	No. of Poles		Additional features		Position of terminal box (gear site)		
DS 080 A	4		/ 00		5		

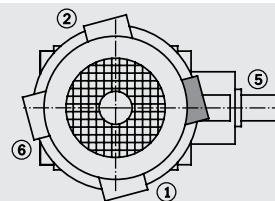

Kegelradgetriebe Typ V
Bevel Gearboxes Type V

Typ VLM 120

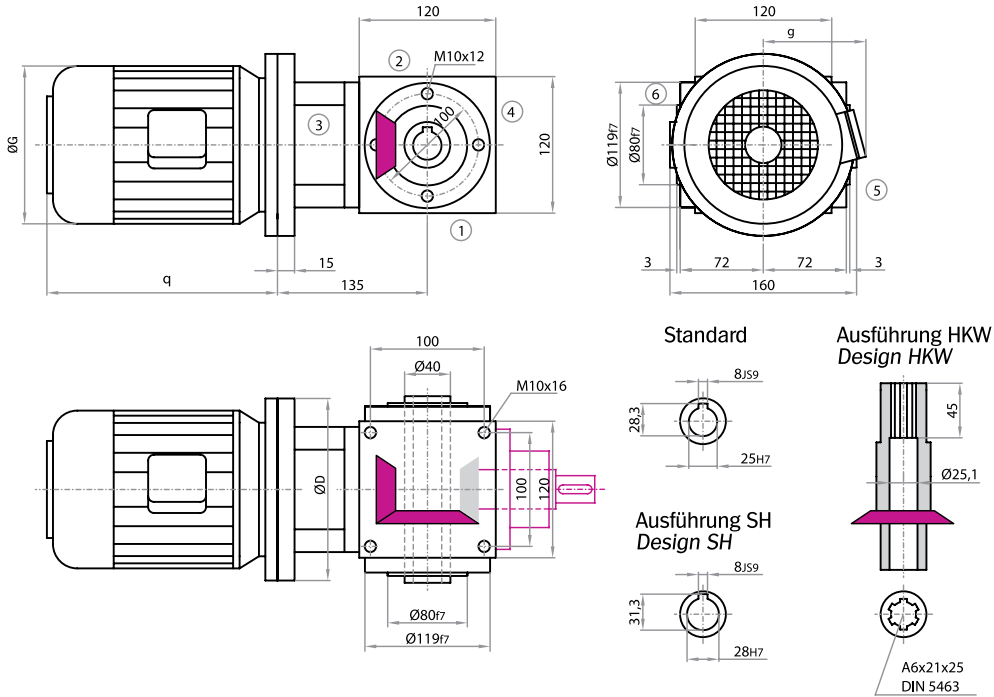

Bauart / Model

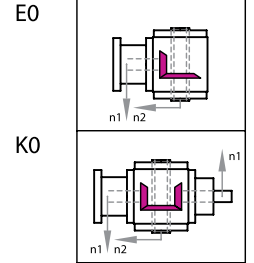

Achtung: Standardbefestigungsgewinde im Gehäuse nur an den Seiten 1, 2 & 4. Alternativ auch an den Seiten 5 & 6 möglich.
Note: Standard fastening thread in the housing only on sides 1, 2 & 4. Alternatively, also possible on sides 5 & 6.

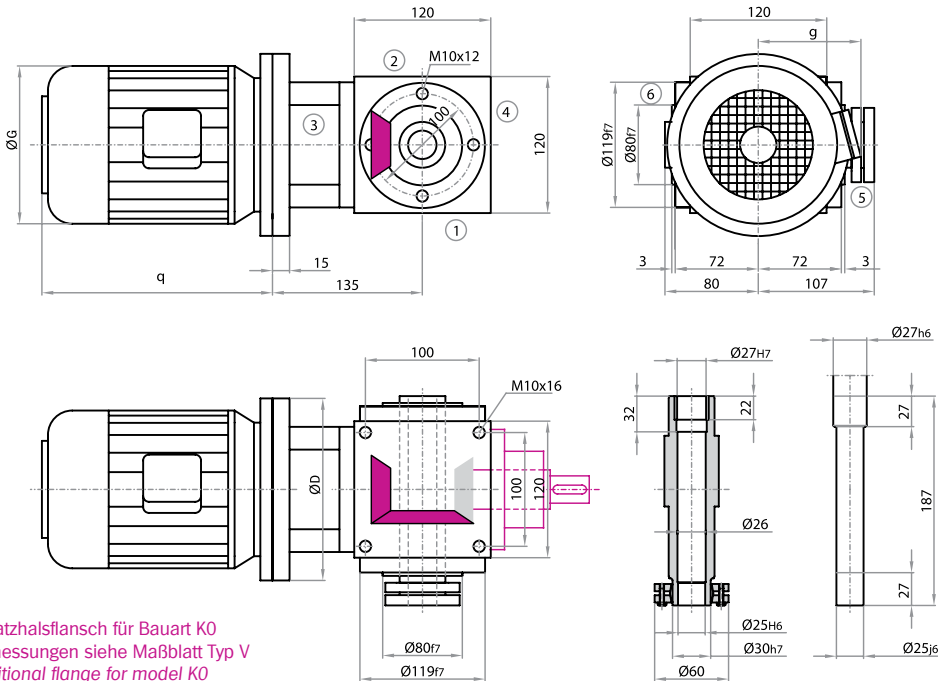

Zusatzflansch für Bauart K0
 Abmessungen siehe Maßblatt Typ V
 Additional flange for model K0
 For measurements refer to type V

Bauart / Model

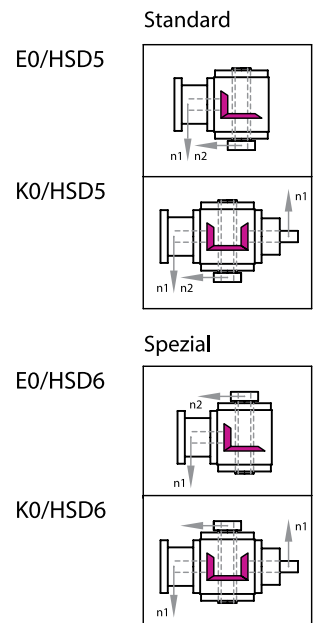

Achtung: Standardbefestigungsgewinde im Gehäuse nur an den Seiten 1, 2 & 4. Alternativ auch an den Seiten 5 & 6 möglich.
Note: Standard fastening thread in the housing only on sides 1, 2 & 4. Alternatively, also possible on sides 5 & 6.

Abmessungen / Measurements

*q1=Bremmotoren / brake motors

Baugröße / Size	Motorabmessungen / Motor Dimensions					
	D	G	g	q	q1*	
080	160	170	126	234	245	
090S	160	185	142	247	273	
090L	160	185	142	272	298	
100/112	200	210	155	301	348	

IV Leistungen, Drehmomente / Power Ratings, Torque Ratings

P1 kW	n2 1/min	T2 Nm	T2N Nm	T2max Nm	i	Motor	P1 kW	n2 1/min	T2 Nm	T2N Nm	T2max Nm	i	Motor	P1 kW	n2 1/min	T2 Nm	T2N Nm	T2max Nm	i	Motor
0,55	272	18,35	72	140	5	080A-4	1,1	227	43,87	79	155	4	090L-6	2,2	1893	10,54	61	100	1,5	090L-2
	172	28,93	82	155	4	090L-8		182	54,83	80	140	5	090L-6		1420	14,06	56	80	2	090L-2
	150	33,27	67	120	6	080B-6		172	57,85	82	155	4	100LB-8		946	21,08	58	155	3	090L-2
	138	36,16	86	140	5	090L-8		152	65,66	67	120	6	090L-6		940	21,23	78	100	1,5	100LA-4
	115	43,39	69	120	6	090L-8		138	72,32	86	140	5	100LB-8		710	28,11	60	155	4	090L-2
0,75	606	11,22	86	100	1,5	090S-6	1,5	2840	4,79	66	220	1	090S-2		626	31,85	80	100	1,5	112M-6
	303	22,43	82	155	3	090S-6		1893	7,19	61	100	1,5	090S-2		568	35,14	60	140	5	090L-2
	272	25,02	72	140	5	080B-4		1420	9,58	56	80	2	090S-2		470	42,47	74	155	3	100LA-4
	227	29,98	64	120	6	080B-4		1380	9,86	82	220	1	090L-4		352	56,62	74	155	4	100LA-4
	182	37,39	80	140	5	090S-6		946	14,38	58	155	3	090S-2		313	63,70	82	155	3	112M-6
	152	44,77	67	113	6	090S-6		920	14,79	78	100	1,5	090L-4		2850	9,55	66	220	1	100L-2
	138	49,31	86	140	5	100LA-8		710	19,17	60	155	4	090S-2	1900	14,33	61	100	1,5	100L-2	
	115	59,17	69	118	6	100LA-8		690	19,72	73	80	2	090L-4	1410	19,30	82	220	1	100LB-4	
1,1	1380	7,23	82	220	1	090S-4	613	22,19	78	100	1,5	100LA-6	940	28,95	78	100	1,5	100LB-4		
	920	10,85	78	100	1,5	090S-4	568	23,96	60	140	5	090S-2	705	38,61	73	80	2	100LB-4		
	690	14,46	73	80	2	090S-4	460	29,58	74	155	3	090L-4	570	47,75	60	140	5	100L-2		
	606	16,45	86	100	1,5	090L-6	345	39,45	74	155	4	090L-4	470	57,91	74	155	3	100LB-4		
	564	17,69	60	140	5	080B-2	306	44,38	82	155	3	100LA-6	2860	12,69	66	220	1	112M-2		
	460	21,70	74	155	3	090S-4	276	49,31	72	140	5	090L-4	1906	19,03	61	100	1,5	112M-2		
	345	28,93	74	155	4	090S-4	230	59,17	64	120	6	090L-4	1420	25,56	82	220	1	112M-4		
	303	32,90	82	155	3	090L-6	184	73,96	80	140	5	100LA-6	946	38,33	78	100	1,5	112M-4		
	276	36,16	72	140	5	090S-4	2,2	2840	7,03	66	220	1	090L-2	710	51,11	73	80	2	112M-4	

Radialkräfte / Radial Forces (N)

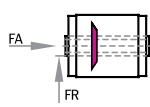

T2 Nm	3000	1000	n2 (1/min) 500	250	100	50
< 80	900	1200	1400	1700	2100	2500
> 80	750	1000	1170	1420	1750	2080

Weitere Erläuterungen und verstärkte Lagerungen siehe Allgemeines / For more information and reinforced bearings, refer to general information.
 Axialkräfte FA = 50% der Radialkräfte - siehe Allgemeines / Axial forces FA = 50% of radial forces - refer to general information.

Massenträgheitsmomente und Getriebegewichte auf Anfrage. Moments of Inertia and gearbox weights available on request.

V Befestigungsseite / Mounting Side

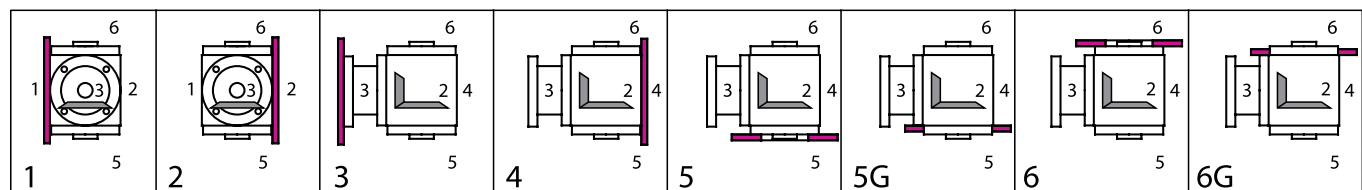

V Einbaulagen (unten liegende Getriebeseite) / Mounting Configuration (downward-facing side)

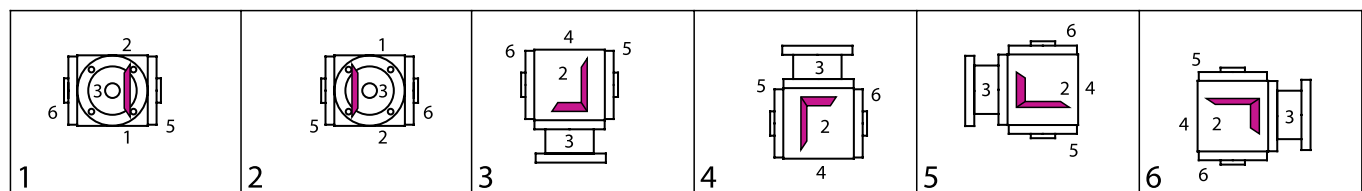

Bestellbeispiel / Example of Order

I Typ	Größe Size	IV Übersetzung Ratio	III Bauart Model	V Befestigungs- Mounting Side	VI Einbaulage Mounting Config.	IV Drehzahl n2max Speed n2max	Ausführung Design
VLM	120	3:1	E0	-	1	-	500 / 0000=Standard
II Motorausführung Motor features	Polzahl No. of Poles		Zusatzausführung Additional features		Klemmenkastenlage (Getriebeseite) Position of terminal box (gear site)		
DS 080 A	-	4	/	00	-		5

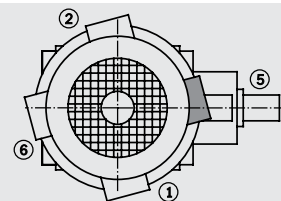

Kegelradgetriebe Typ V
Bevel Gearboxes Type V

Typ VLM 140

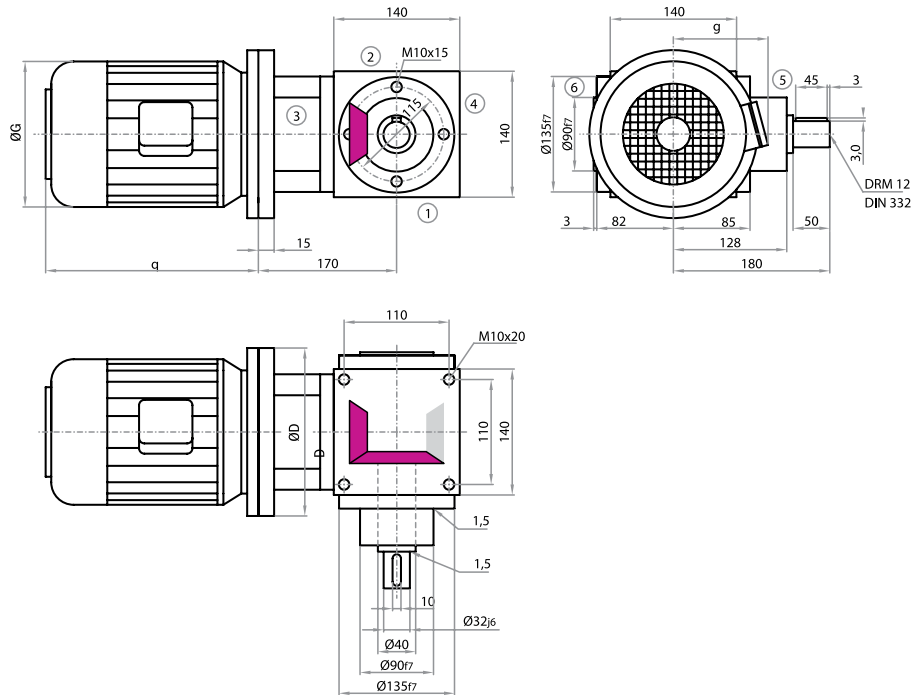

Bauart / Model

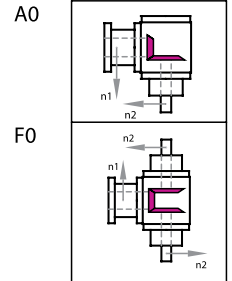

Achtung: Standardbefestigungsgewinde im Gehäuse nur an den Seiten 1, 2 & 4. Alternativ auch an den Seiten 5 & 6 möglich.
Note: Standard fastening thread in the housing only on sides 1, 2 & 4. Alternatively, also possible on sides 5 & 6.

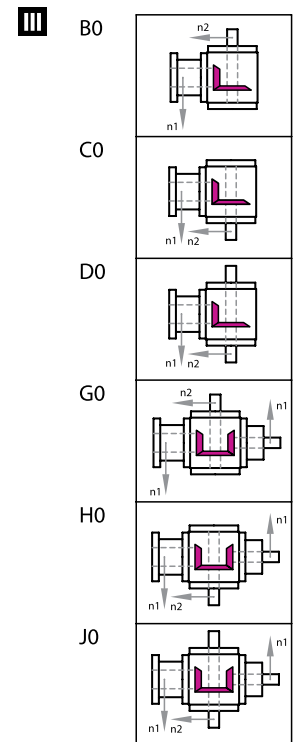
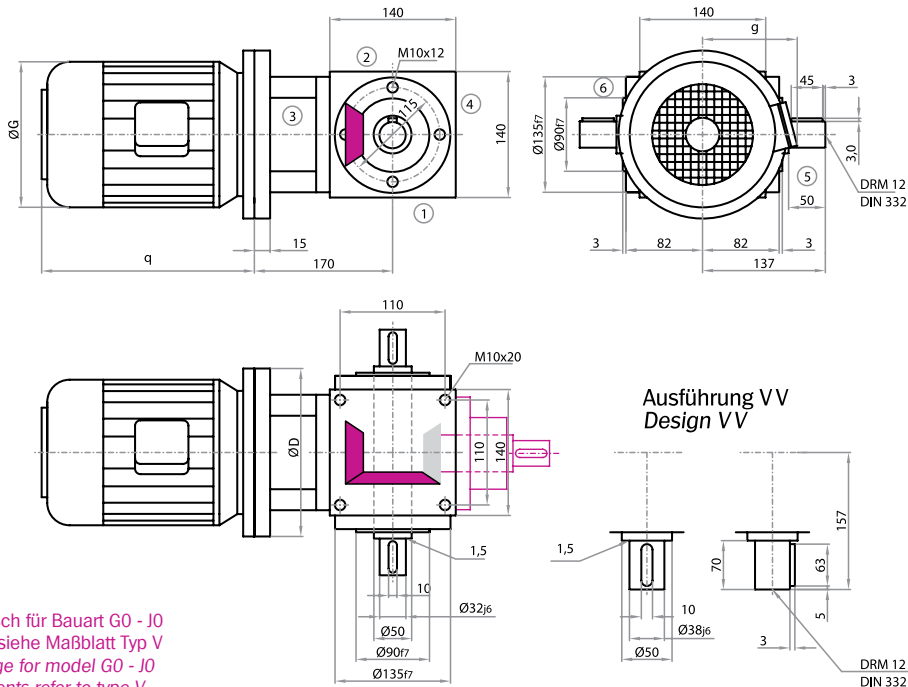

Zusatzflansch für Bauart G0 - J0
 Abmessungen siehe Maßblatt Typ V
 Additional flange for model G0 - J0
 For measurements refer to type V

Achtung: Standardbefestigungsgewinde im Gehäuse nur an den Seiten 1, 2 & 4. Alternativ auch an den Seiten 5 & 6 möglich.
Note: Standard fastening thread in the housing only on sides 1, 2 & 4. Alternatively, also possible on sides 5 & 6.

Abmessungen / Measurements

*q1=Bremmotoren / brake motors

Baugröße / Size	Motorabmessungen / Motor Dimensions					
	D	G	g	q	q1*	
090S	200	185	142	247	273	
090L	200	185	142	272	298	
100/112	200	210	155	301	348	
132S	200	260	200	390	428	
132M	200	260	200	416	454	

IV Leistungen, Drehmomente / Power Ratings, Torque Ratings

[n=min-1, P=kW, T=Nm]

P1 kW	n2 1/min	T2 Nm	T2N Nm	T2max Nm	i	Motor
1,5	154	88,37	113	200	6	100LA-6
	140	97,21	130	250	5	112M-8
	117	116,31	118	200	6	112M-8
2,2	235	84,93	136	280	4	112M-6
	235	84,93	108	200	6	100LA-4
	188	106,17	124	250	5	112M-6
	177	112,77	148	280	4	132SB-8
3,0	633	42,98	175	210	1,5	132SB-6
	475	57,3	152	180	2	132SB-6
	316	85,95	160	280	3	132SB-6
	282	96,52	115	250	5	100LB-4
	237	114,6	136	280	4	132SB-6
4,0	633	57,3	175	210	1,5	132MA-6
	572	63,44	100	250	5	112M-2
	475	76,4	152	180	2	132MA-6
	355	102,23	120	280	4	112M-4
	316	114,6	160	280	3	132MA-6
5,5	2900	17,33	120	430	1	132SA-2
	1933	25,99	113	210	1,5	132SA-2
	1450	34,41	100	180	2	132SA-2
	1430	34,89	162	430	1	132SB-4

P1 kW	n2 1/min	T2 Nm	T2N Nm	T2max Nm	i	Motor
5,5	966	51,62	110	280	3	132SA-2
	953	52,34	155	210	1,5	132SB-4
	950	52,53	184	430	1	132MB-6
	715	69,79	138	180	2	132SB-4
	633	78,79	175	210	1,5	132MB-6
	580	86,03	100	250	5	132SA-2
	476	104,68	146	280	3	132SB-4
	316	157,58	160	280	3	132MB-6
7,5	2900	23,46	120	430	1	132SB-2
	1933	35,2	113	180	1,5	132SB-2
	1430	47,58	162	430	1	132MB-4
	966	70,39	110	280	3	132SB-2
	953	71,37	155	210	1,5	132MB-4
	715	95,17	138	180	2	132MB-4
	476	142,75	146	280	3	132MB-4
9,0	2910	28,06	120	430	1	132MA-2
	1940	42,09	113	210	1,5	132MA-2
	1430	57,1	162	430	1	132MC-4
	970	84,18	110	280	3	132MA-2
	953	85,65	155	210	1,5	132MC-4
	715	114,2	138	180	2	132MC-4

Radialkräfte / Radial Forces (N)

T2 Nm	n2 (1/min)					
	3000	1000	500	250	100	50
< 140	700	870	1150	1370	1700	2000
> 140	590	730	960	1140	1420	1670

Weitere Erläuterungen und verstärkte Lagerungen siehe Allgemeines / For more information and reinforced bearings, refer to general information.
 Axialkräfte FA = 50% der Radialkräfte - siehe Allgemeines / Axial forces FA = 50% of radial forces - refer to general information.

Massenträgheitsmomente und Getriebegewichte auf Anfrage. Moments of Inertia and gearbox weights available on request.

V Befestigungsseite / Mounting Side

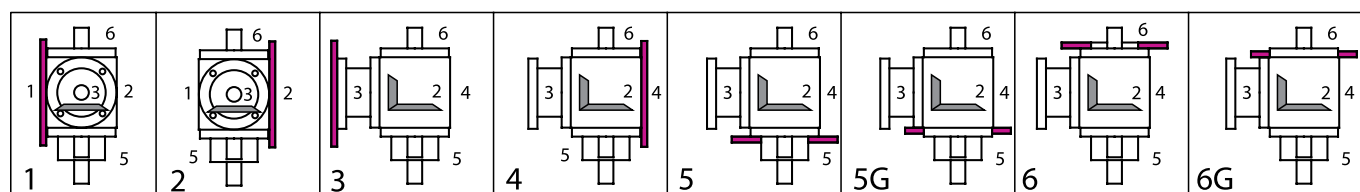

VI Einbautagen (unten liegende Getriebeseite) / Mounting Configuration (downward-facing side)

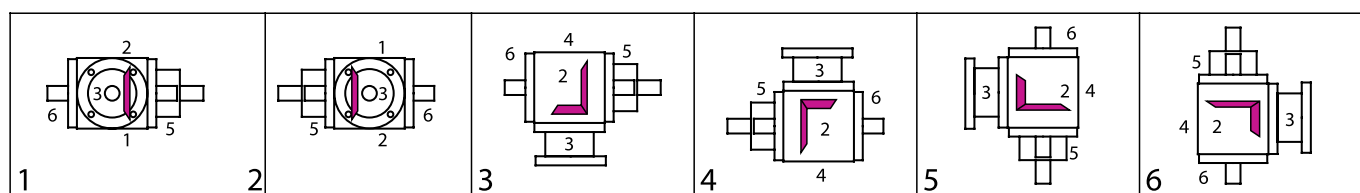

Bestellbeispiel / Example of Order

I Typ	Größe Size	IV Übersetzung Ratio	III Bauart Model	V Befestigungs- Mounting Side	VI Einbautage Mounting Config.	IV Drehzahl n2max Speed n2max	Ausführung Design
VLM	140	3:1	A0	1	1	500	0000=Standard
II Motorausführung Motor features	Polzahl No. of Poles	Zusatzausführung Additional features	Klemmenkastenlage (Getriebeseite) Position of terminal box (gear site)				
DS 090 S	4	/ 00					5

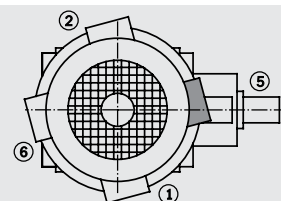

Kegelradgetriebe Typ V
Bevel Gearboxes Type V

Typ VLM 140

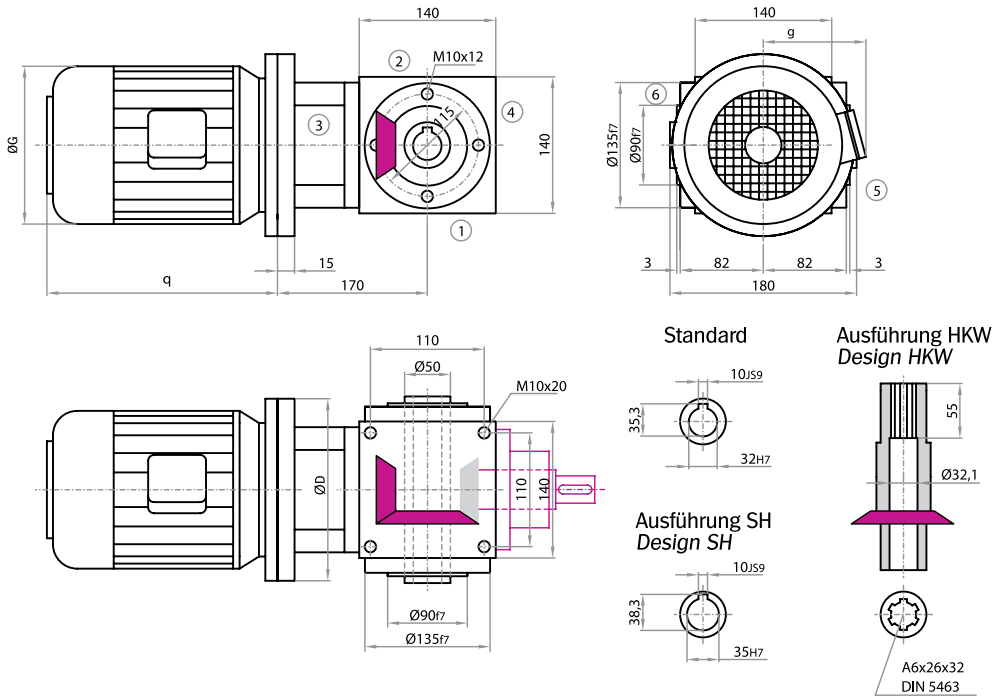

Bauart / Model

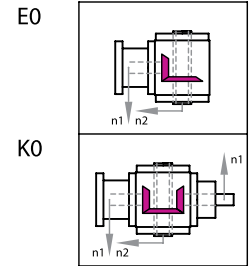

Achtung: Standardbefestigungsgewinde im Gehäuse nur an den Seiten 1, 2 & 4. Alternativ auch an den Seiten 5 & 6 möglich.
Note: Standard fastening thread in the housing only on sides 1, 2 & 4. Alternatively, also possible on sides 5 & 6.

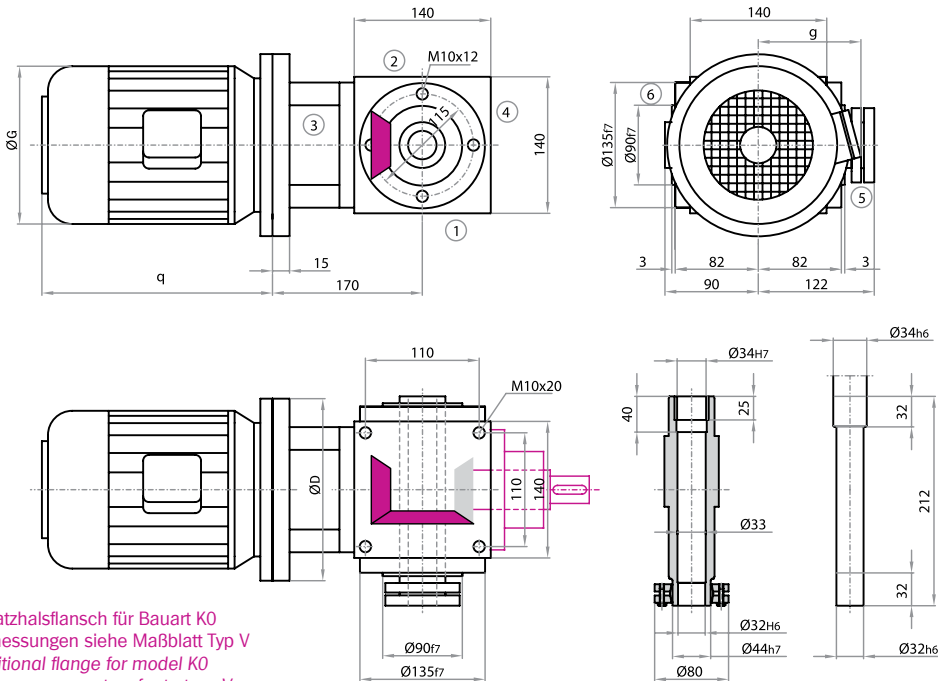

Bauart / Model

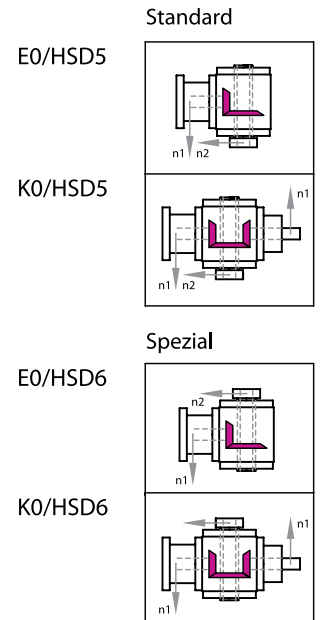

Zusatzflansch für Bauart K0
 Abmessungen siehe Maßblatt Typ V
 Additional flange for model K0
 For measurements refer to type V

Achtung: Standardbefestigungsgewinde im Gehäuse nur an den Seiten 1, 2 & 4. Alternativ auch an den Seiten 5 & 6 möglich.
Note: Standard fastening thread in the housing only on sides 1, 2 & 4. Alternatively, also possible on sides 5 & 6.

Abmessungen / Measurements

*q1=Bremmotoren / brake motors

Baugröße / Size	Motorabmessungen / Motor Dimensions					q1*
	D	G	g	q		
090S	200	185	142	247	273	
090L	200	185	142	272	298	
100/112	200	210	155	301	348	
132S	200	260	200	390	428	
132M	200	260	200	416	454	

IV Leistungen, Drehmomente / Power Ratings, Torque Ratings

P1 kW	n2 1/min	T2 Nm	T2N Nm	T2max Nm	i	Motor
1,5	154	88,37	113	200	6	100LA-6
	140	97,21	130	250	5	112M-8
	117	116,31	118	200	6	112M-8
2,2	235	84,93	136	280	4	112M-6
	235	84,93	108	200	6	100LA-4
	188	106,17	124	250	5	112M-6
	177	112,77	148	280	4	132SB-8
3,0	633	42,98	175	210	1,5	132SB-6
	475	57,3	152	180	2	132SB-6
	316	85,95	160	280	3	132SB-6
	282	96,52	115	250	5	100LB-4
	237	114,6	136	280	4	132SB-6
4,0	633	57,3	175	210	1,5	132MA-6
	572	63,44	100	250	5	112M-2
	475	76,4	152	180	2	132MA-6
	355	102,23	120	280	4	112M-4
	316	114,6	160	280	3	132MA-6
5,5	2900	17,33	120	430	1	132SA-2
	1933	25,99	113	210	1,5	132SA-2
	1450	34,41	100	180	2	132SA-2
	1430	34,89	162	430	1	132SB-4

P1 kW	n2 1/min	T2 Nm	T2N Nm	T2max Nm	i	Motor
5,5	966	51,62	110	280	3	132SA-2
	953	52,34	155	210	1,5	132SB-4
	950	52,53	184	430	1	132MB-6
	715	69,79	138	180	2	132SB-4
	633	78,79	175	210	1,5	132MB-6
	580	86,03	100	250	5	132SA-2
7,5	476	104,68	146	280	3	132SB-4
	316	157,58	160	280	3	132MB-6
	2900	23,46	120	430	1	132SB-2
	1933	35,2	113	180	1,5	132SB-2
	1430	47,58	162	430	1	132MB-4
	966	70,39	110	280	3	132SB-2
	953	71,37	155	210	1,5	132MB-4
	715	95,17	138	180	2	132MB-4
	476	142,75	146	280	3	132MB-4
	9,0	2910	28,06	120	430	1
1940		42,09	113	210	1,5	132MA-2
1430		57,1	162	430	1	132MC-4
970		84,18	110	280	3	132MA-2
953		85,65	155	210	1,5	132MC-4
715		114,2	138	180	2	132MC-4

Radialkräfte / Radial Forces (N)

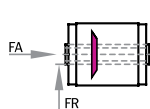

T2 Nm	n2 (1/min)					
	3000	1000	500	250	100	50
< 140	1300	1700	2000	2500	3000	3800
> 140	1083	1420	1670	2080	2500	3170

Weitere Erläuterungen und verstärkte Lagerungen siehe Allgemeines / For more information and reinforced bearings, refer to general Information.
 Axialkräfte FA = 50% der Radialkräfte - siehe Allgemeines / Axial forces FA = 50% of radial forces - refer to general information.

Massenträgheitsmomente und Getriebegewichte auf Anfrage. Moments of Inertia and gearbox weights available on request.

V Befestigungsseite / Mounting Side

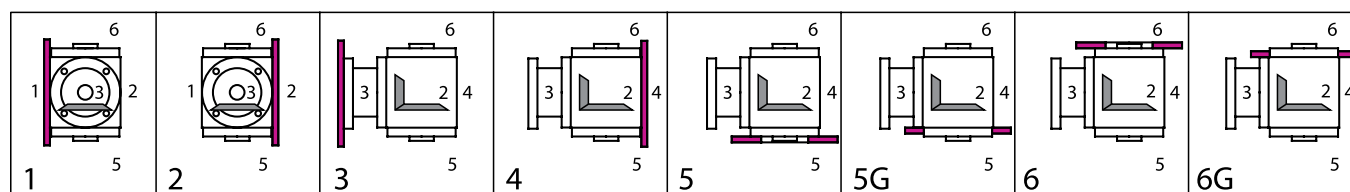

VI Einbaulagen (unten liegende Getriebeseite) / Mounting Configuration (downward-facing side)

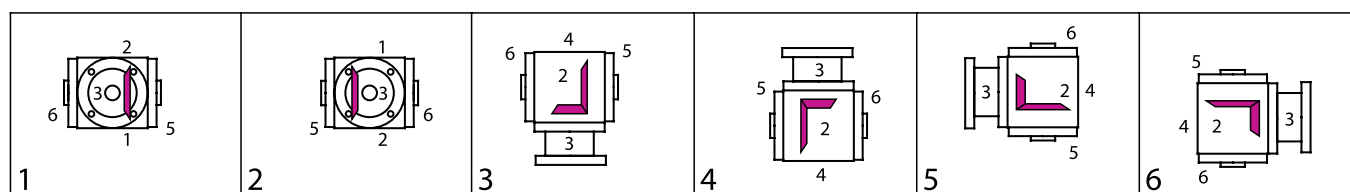

Bestellbeispiel / Example of Order

I Typ	Größe Size	IV Übersetzung Ratio	III Bauart Model	V Befestigungs- Mounting Side	VI Einbaulage Mounting Config.	IV Drehzahl n2max Speed n2max	Ausführung Design
VLM	140	3:1	E0	-	1	-	500 / 0000=Standard
III Motorausführung Motor features	Polzahl No. of Poles		Zusatzausführung Additional features				Klemmenkastenlage (Getriebeseite) Position of terminal box (gear site)
DS 090 S	-	4	/	00			5

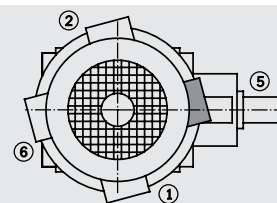

Kegelradgetriebe Typ V
Bevel Gearboxes Type V

Typ VLM 160

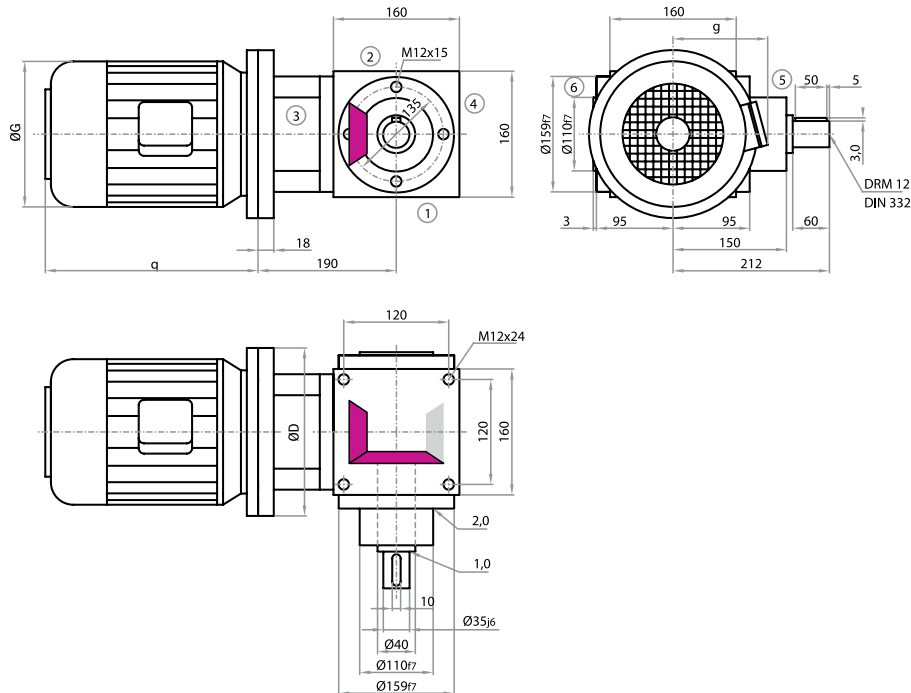

Bauart / Model

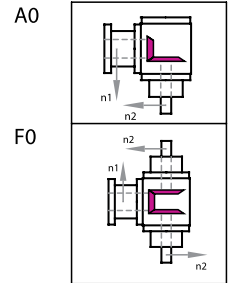

Achtung: Standardbefestigungsgewinde im Gehäuse nur an den Seiten 1, 2 & 4.
 Alternativ auch an den Seiten 5 & 6 im Rastermaß 130x130 möglich.
Note: Standard fastening thread in the housing only on sides 1, 2 & 4.
 Alternatively, also possible in the grid dimension of 130x130 on sides 5 & 6.

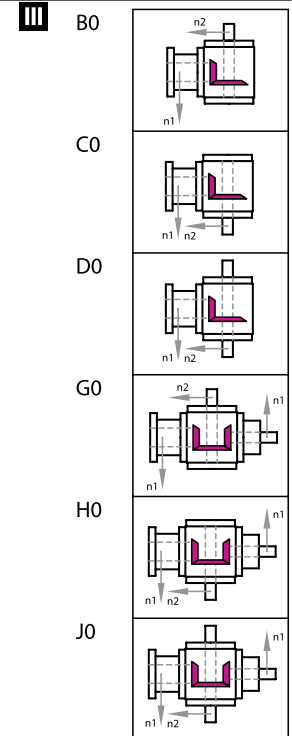
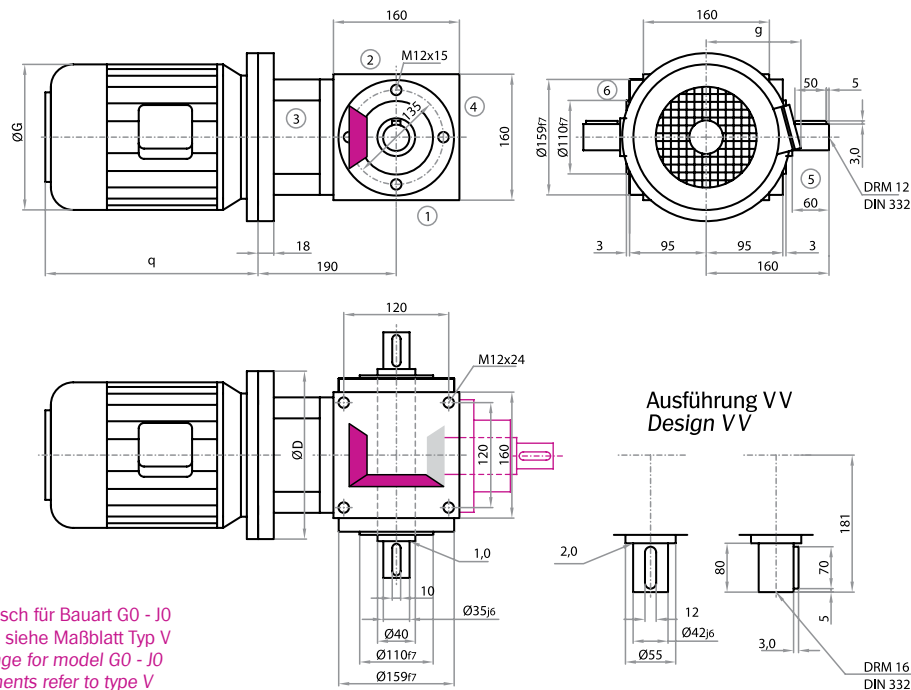

Zusatzflansch für Bauart G0 - J0
 Abmessungen siehe Maßblatt Typ V
 Additional flange for model G0 - J0
 For measurements refer to type V

Achtung: Standardbefestigungsgewinde im Gehäuse nur an den Seiten 1, 2 & 4.
 Alternativ auch an den Seiten 5 & 6 im Rastermaß 130x130 möglich.
Note: Standard fastening thread in the housing only on sides 1, 2 & 4.
 Alternatively, also possible in the grid dimension of 130x130 on sides 5 & 6.

Abmessungen / Measurements

*q1=Bremmotoren / brake motors

Baugröße / Size	Motorabmessungen / Motor Dimensions				
	D	G	g	q	q1*
090S	200	185	142	247	273
090L	200	185	142	272	298
100/112	200	210	155	301	348
132S	200	260	200	390	428
132M	200	260	200	416	454

IV Leistungen, Drehmomente / Power Ratings, Torque Ratings

P1 kW	n2 1/min	T2 Nm	T2N Nm	T2max Nm	i	Motor
2,2	157	127,13	165	200	6	112M-6
	141	141,56	240	420	5	132SB-8
	118	169,15	178	200	6	132SB-8
3,0	235	115,82	145	350	6	100LB-4
	190	143,25	225	420	5	132SB-6
	177	153,34	250	422	4	132MB-8
	142	191,67	240	420	5	132MB-8
4,0	355	102,23	220	422	4	112M-4
	284	127,78	215	420	5	112M-4
	237	152,80	240	422	4	132MA-6
	190	191,00	225	420	5	132MA-6
5,5	476	104,68	230	457	3	132SB-4
	357	139,58	220	422	4	132SB-4
	316	157,58	245	457	3	132MB-6
	286	174,47	215	420	5	132SB-4
	237	210,10	240	422	4	132MB-6

P1 kW	n2 1/min	T2 Nm	T2N Nm	T2max Nm	i	Motor
7,5	580	117,32	180	420	5	132SB-2
	476	142,75	230	457	3	132MB-4
	357	190,33	220	422	4	132MB-4
9,0	1430	57,10	260	660	1	132MC-4
	970	84,18	190	457	3	132MA-2
	953	85,65	252	360	1,5	132MC-4
	727	112,24	180	422	4	132MA-2
	715	114,20	245	320	2	132MC-4
	582	140,30	180	420	5	132MA-2
	476	171,30	230	457	3	132MC-4
	357	228,40	220	422	4	132MC-4

Radialkräfte / Radial Forces (N)

FA	FR	T2 Nm	n2 (1/min)					FA	FR	T2 Nm	n2 (1/min)													
			3000	1000	500	250	100				50	3000	1000	500	250	100	50							
↙	↑	220	1200	1600	1900	2200	2850	3300	↙	220	1200	1600	1900	2200	2850	3300	↙	220	1200	1600	1900	2200	2850	3300
↘	↑	220	1000	1340	1590	1840	2380	2750	↘	220	1000	1340	1590	1840	2380	2750	↘	220	1000	1340	1590	1840	2380	2750

Weitere Erläuterungen und verstärkte Lagerungen siehe Allgemeines / For more information and reinforced bearings, refer to general information.
 Axialkräfte FA = 50% der Radialkräfte - siehe Allgemeines / Axial forces FA = 50% of radial forces - refer to general information.

Massenträgheitsmomente und Getriebegewichte auf Anfrage. Moments of Inertia and gearbox weights available on request.

V Befestigungsseite / Mounting Side

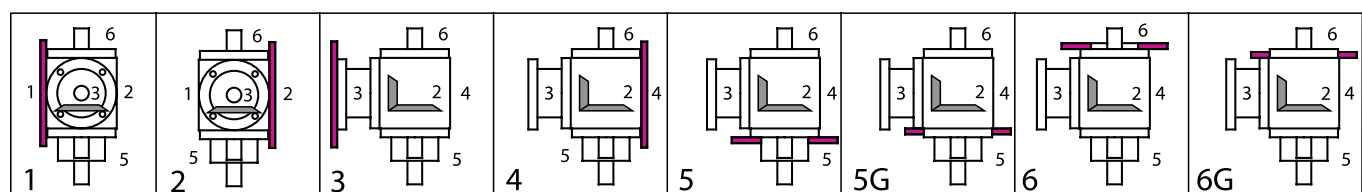

VI Einbautagen (unten liegende Getriebeseite) / Mounting Configuration (downward-facing side)

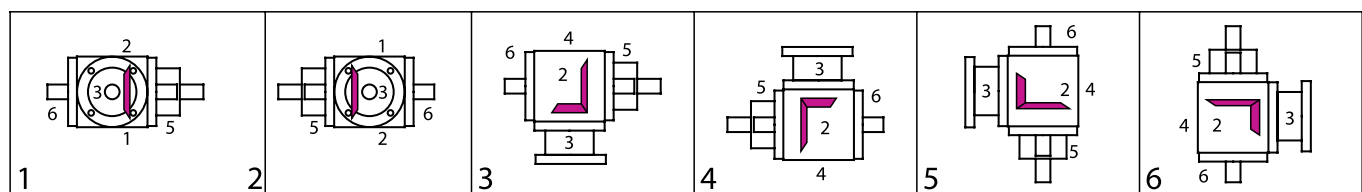

Bestellbeispiel / Example of Order

I Typ	Größe	IV Übersetzung	III Bauart	V Befestigungs-	VI Einbautage	IV Drehzahl	Ausführung
VLM	160	5:1	A0	1	.	300	0000=Standard
III Motorausführung	Polzahl		Zusatzausführung		Klemmenkastenlage (Getriebeseite)		
Motor features	No. of Poles		Additional features		Position of terminal box (gear site)		
DS 100 LA	4		/ 00		5		

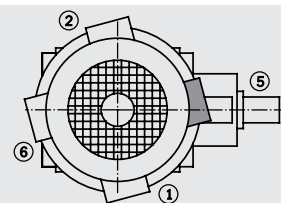

Kegelradgetriebe Typ V
 Bevel Gearboxes Type V

Typ VLM 160

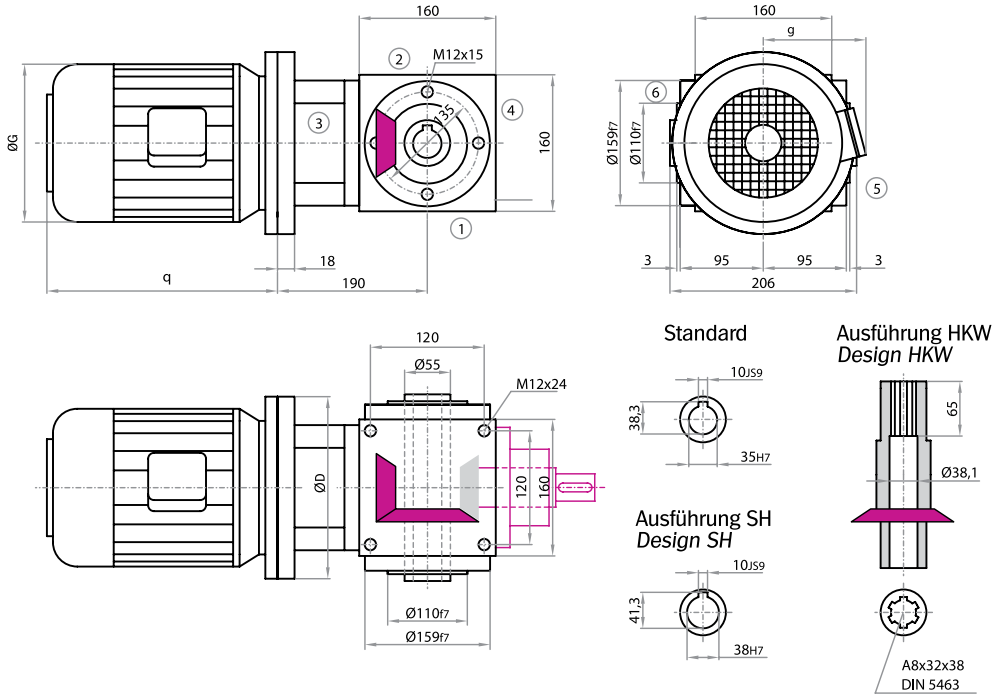

Achtung: Standardbefestigungsgewinde im Gehäuse nur an den Seiten 1, 2 & 4.
 Alternativ auch an den Seiten 5 & 6 im Rastermaß 130x130 möglich.
Note: Standard fastening thread in the housing only on sides 1, 2 & 4.
 Alternatively, also possible in the grid dimension of 130x130 on sides 5 & 6.

Bauart / Model

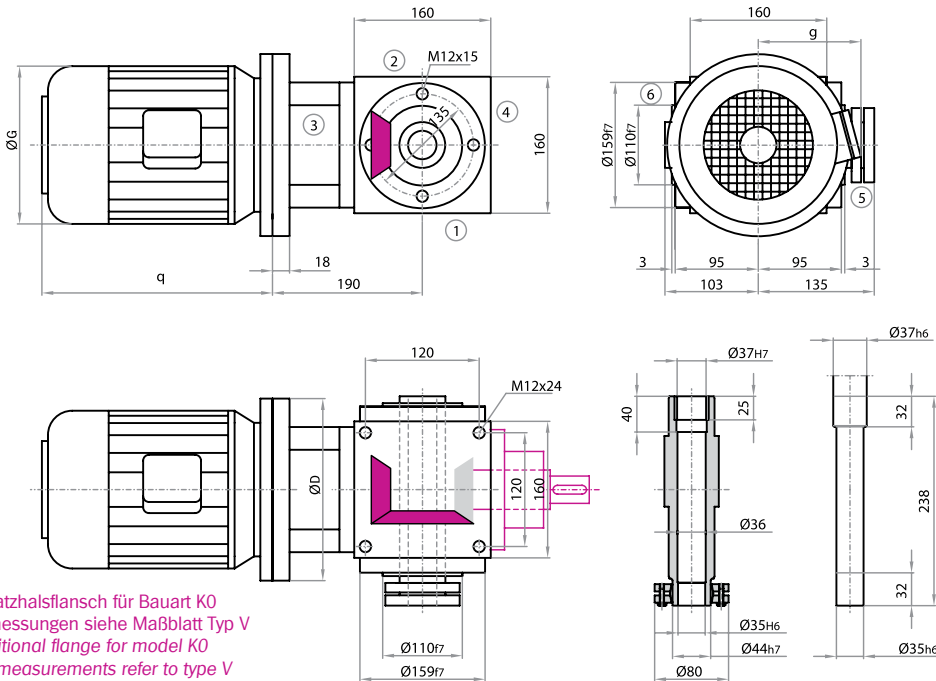
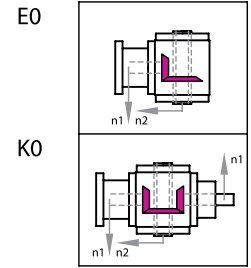

Zusatzflansch für Bauart K0
 Abmessungen siehe Maßblatt Typ V
 Additional flange for model K0
 For measurements refer to type V

Achtung: Standardbefestigungsgewinde im Gehäuse nur an den Seiten 1, 2 & 4.
 Alternativ auch an den Seiten 5 & 6 im Rastermaß 130x130 möglich.
Note: Standard fastening thread in the housing only on sides 1, 2 & 4.
 Alternatively, also possible in the grid dimension of 130x130 on sides 5 & 6.

Bauart / Model

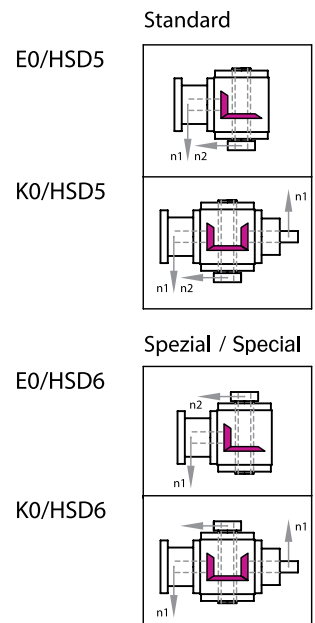

Abmessungen / Measurements

*q1=Bremstromotoren / brake motors

Motorabmessungen / Motor Dimensions					
Baugröße / Size	D	G	g	q	q1*
090S	200	185	142	247	273
090L	200	185	142	272	298
100/112	200	210	155	301	348
132S	200	260	200	390	428
132M	200	260	200	416	454

IV Leistungen, Drehmomente / Power Ratings, Torque Ratings

P1 kW	n2 1/min	T2 Nm	T2N Nm	T2max Nm	i	Motor
2,2	157	127,13	165	200	6	112M-6
	141	141,56	240	420	5	132SB-8
	118	169,15	178	200	6	132SB-8
3,0	235	115,82	145	350	6	100LB-4
	190	143,25	225	420	5	132SB-6
	177	153,34	250	422	4	132MB-8
	142	191,67	240	420	5	132MB-8
4,0	355	102,23	220	422	4	112M-4
	284	127,78	215	420	5	112M-4
	237	152,80	240	422	4	132MA-6
	190	191,00	225	420	5	132MA-6
5,5	476	104,68	230	457	3	132SB-4
	357	139,58	220	422	4	132SB-4
	316	157,58	245	457	3	132MB-6
	286	174,47	215	420	5	132SB-4
	237	210,10	240	422	4	132MB-6

P1 kW	n2 1/min	T2 Nm	T2N Nm	T2max Nm	i	Motor
7,5	580	117,32	180	420	5	132SB-2
	476	142,75	230	457	3	132MB-4
	357	190,33	220	422	4	132MB-4
9,0	1430	57,10	260	660	1	132MC-4
	970	84,18	190	457	3	132MA-2
	953	85,65	252	360	1,5	132MC-4
	727	112,24	180	422	4	132MA-2
	715	114,20	245	320	2	132MC-4
	582	140,30	180	420	5	132MA-2
	476	171,30	230	457	3	132MC-4
	357	228,40	220	422	4	132MC-4

Radialkräfte / Radial Forces (N)

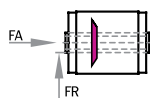

T2 Nm	n2 (1/min)					
	3000	1000	500	250	100	50
< 220	2300	3100	3600	4300	5300	7000
> 220	1920	2580	3000	3580	4420	5830

Weitere Erläuterungen und verstärkte Lagerungen siehe Allgemeines / For more information and reinforced bearings, refer to general information.
 Axialkräfte FA = 50% der Radialkräfte - siehe Allgemeines / Axial forces FA = 50% of radial forces - refer to general information.

**Massenträgheitsmomente und Getriebegewichte auf Anfrage.
 Moments of Inertia and gearbox weights available on request.**

V Befestigungsseite / Mounting Side

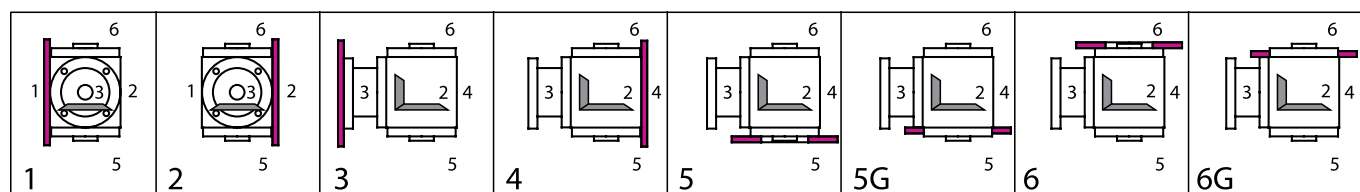

VI Einbautagen (unten liegende Getriebeseite) / Mounting Configuration (downward-facing side)

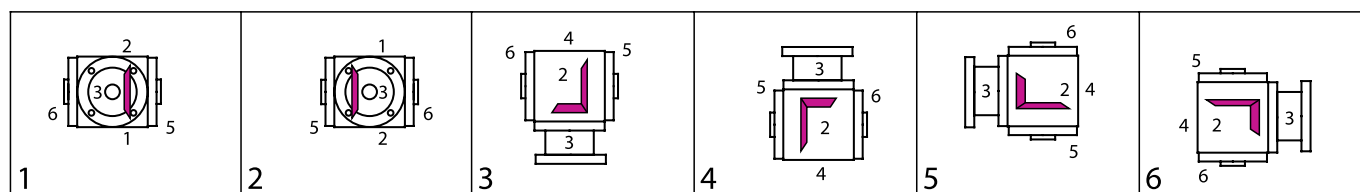

Bestellbeispiel / Example of Order

I Typ	Größe Size	IV Übersetzung Ratio	III Bauart Model	V Befestigungs- Mounting Side	VI Einbautage Mounting Config.	IV Drehzahl n2max Speed n2max	Ausführung Design
VLM	160	5:1	E0	1	1	300	0000=Standard
II Motorausführung Motor features	Polzahl No. of Poles	Zusatzausführung Additional features			Klemmenkastenlage (Getriebeseite) Position of terminal box (gear site)		
DS 100 LA	4	/ 00			5		

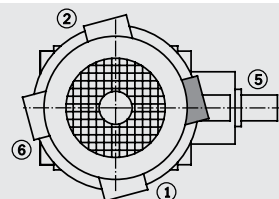

Kegelradgetriebe Typ V
Bevel Gearboxes Type V

Typ VLM 200

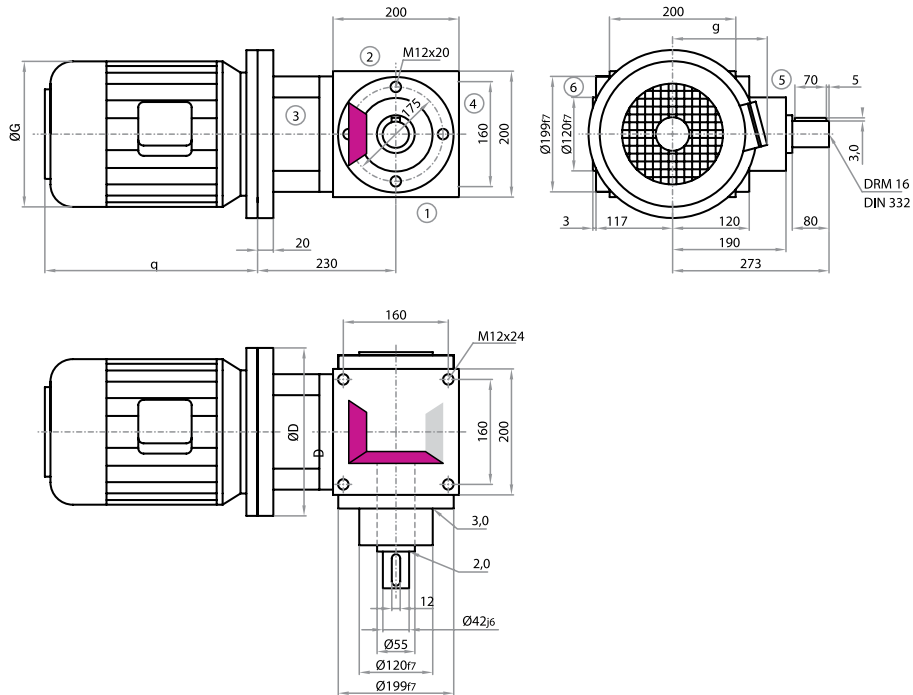

Bauart / Model

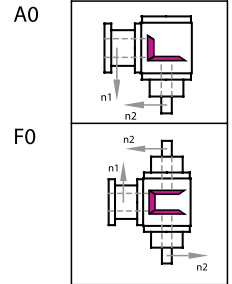

Achtung: Standardbefestigungsgewinde im Gehäuse nur an den Seiten 1, 2 & 4. Alternativ auch an den Seiten 5 & 6 möglich.
Note: Standard fastening thread in the housing only on sides 1, 2 & 4. Alternatively, also possible on sides 5 & 6.

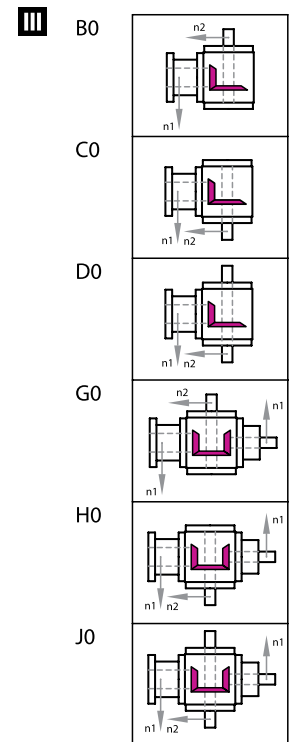
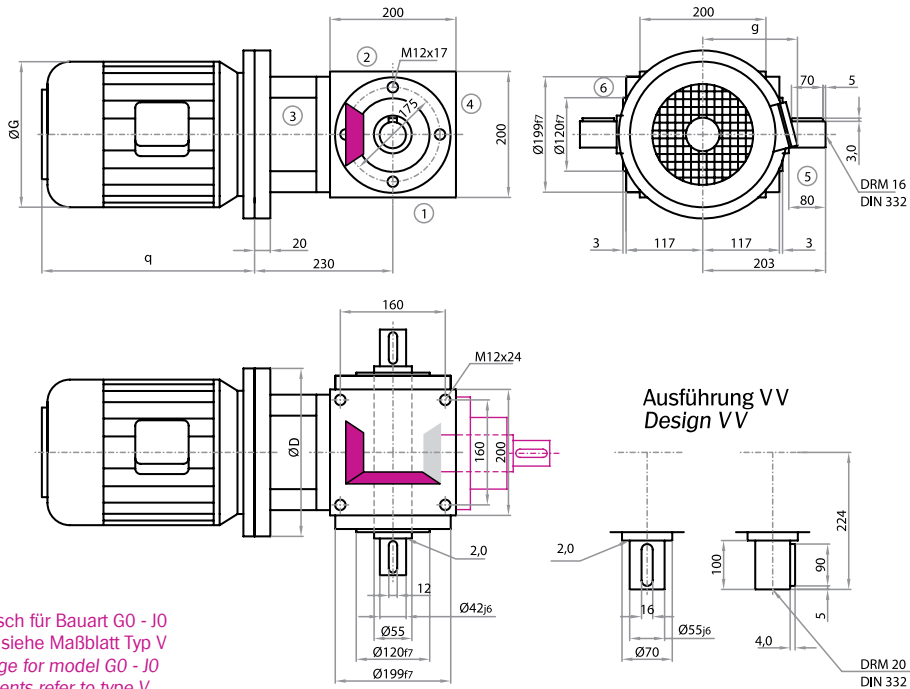

Zusatzflansch für Bauart G0 - J0
 Abmessungen siehe Maßblatt Typ V
 Additional flange for model G0 - J0
 For measurements refer to type V

Achtung: Standardbefestigungsgewinde im Gehäuse nur an den Seiten 1, 2 & 4. Alternativ auch an den Seiten 5 & 6 möglich.
Note: Standard fastening thread in the housing only on sides 1, 2 & 4. Alternatively, also possible on sides 5 & 6.

Abmessungen / Measurements

*q1=Bremmotoren / brake motors

Motorabmessungen / Motor Dimensions					
Baugröße / Size	D	G	g	q	q1*
100/112	200	210	155	301	348
132S	200	260	200	390	428
132M	200	260	200	416	454
160	250	320	245	540	
180	250	320	245	580	

IV Leistungen, Drehmomente / Power Ratings, Torque Ratings

P1 kW	n2 1/min	T2 Nm	T2N Nm	T2max Nm	i	Motor
4,0	177,0	204,5	510,0	860,0	4,0	160MA-8
	142,0	255,6	440,0	860,0	5,0	160MA-8
5,5	238,0	209,4	580,0	910,0	3,0	160LA-8
	190,0	262,6	420,0	860,0	5,0	132MB-6
	178,0	279,2	510,0	860,0	4,0	160LA-8
	143,0	348,9	440,0	860,0	5,0	160LA-8
7,5	640,0	106,3	505,0	600,0	1,5	160MB-6
	480,0	141,8	500,0	530,0	2,0	160MB-6
	320,0	212,6	555,0	910,0	3,0	160MB-6
	286,0	237,9	380,0	860,0	5,0	132MB-4
	240,0	283,5	485,0	860,0	4,0	160MB-6
	192,0	354,4	420,0	860,0	5,0	160MB-6
	180,0	378,0	510,0	860,0	4,0	160LB-8
9,0	286,0	285,5	380,0	860,0	5,0	132MC-4
11,0	1940,0	51,4	330,0	600,0	1,5	160MA-2
	1465,0	68,1	450,0	1090,0	1,0	160MB-4
	976,0	102,2	437,0	600,0	1,5	160MB-4
	732,0	136,2	425,0	530,0	2,0	160MB-4
	640,0	155,9	505,0	600,0	1,5	160LA-6
	582,0	171,5	300,0	860,0	5,0	160MA-2
	488,0	204,4	515,0	910,0	3,0	160MB-4
	366,0	272,5	455,0	860,0	4,0	160MB-4
	320,0	311,9	555,0	910,0	3,0	160LA-6

P1 kW	n2 1/min	T2 Nm	T2N Nm	T2max Nm	i	Motor	
11,0	293,0	340,6	380,0	860,0	5,0	160MB-4	
	240,0	415,8	485,0	860,0	4,0	160LA-6	
15,0	1953,0	69,7	330,0	600,0	1,5	160MB-2	
	1465,0	92,9	450,0	1090,0	1,0	160LA-4	
	976,0	139,3	437,0	600,0	1,5	160LA-4	
	732,0	185,8	425,0	530,0	2,0	160LA-4	
	646,0	210,4	505,0	600,0	1,5	180L-6	
	586,0	232,2	300,0	860,0	5,0	160MB-2	
	488,0	278,7	515,0	910,0	3,0	160LA-4	
	366,0	371,6	455,0	860,0	4,0	160LA-4	
	323,0	420,9	555,0	910,0	3,0	180L-6	
	18,5	1960,0	85,6	330,0	600,0	1,5	160L-2
1470,0		114,2	450,0	1090,0	1,0	180M-4	
980,0		171,3	437,0	600,0	1,5	180M-4	
735,0		228,4	425,0	530,0	2,0	180M-4	
588,0		285,4	300,0	860,0	5,0	160L-2	
490,0		342,5	515,0	910,0	3,0	180M-4	
367,0		456,7	455,0	860,0	4,0	180M-4	
22,0		1470,0	135,8	450,0	1090,0	1,0	180L-4
		980,0	203,7	437,0	600,0	1,5	180L-4
		735,0	271,6	425,0	530,0	2,0	180L-4
	490,0	407,3	515,0	910,0	3,0	180L-4	

Radialkräfte / Radial Forces (N)

FA	FR	T2 Nm	n2 (1/min)						FA	FR	T2 Nm	n2 (1/min)					
			3000	1000	500	250	100	50				3000	1000	500	250	100	50
< 500	2200	1700	3200	3900	5000	6200	3200	4300	5000	6500	8000	10000					
> 500	1840	1420	2670	3250	4170	5170	2670	3580	4170	5420	6670	8330					

Weitere Erläuterungen und verstärkte Lagerungen siehe Allgemeines / For more information and reinforced bearings, refer to general Information.
 Axialkräfte FA = 50% der Radialkräfte - siehe Allgemeines / Axial forces FA = 50% of radial forces - refer to general information.

Massenträgheitsmomente und Getriebegewichte auf Anfrage. Moments of Inertia and gearbox weights available on request.

V Befestigungsseite / Mounting Side

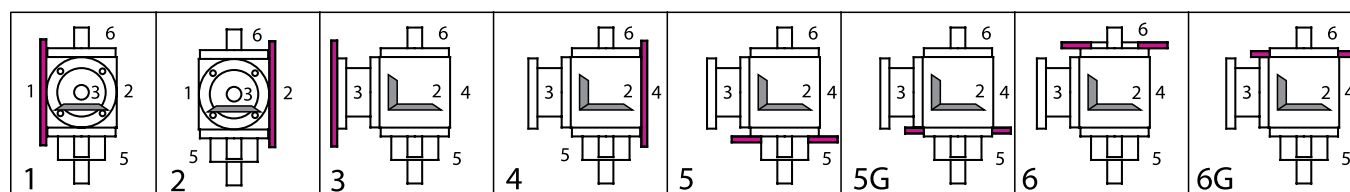

VI Einbaulagen (unten liegende Getriebeseite) / Mounting Configuration (downward-facing side)

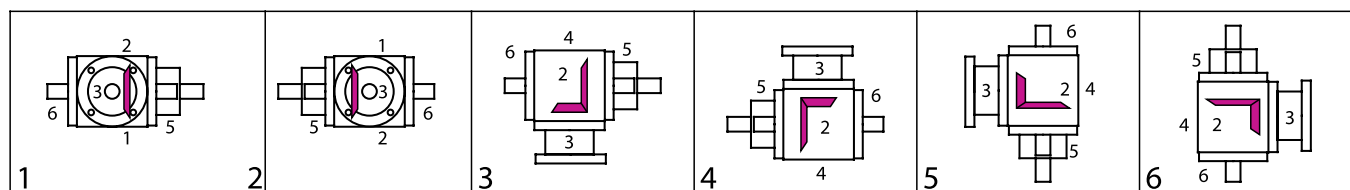

Bestellbeispiel / Example of Order

I Typ	Größe Size	IV Übersetzung Ratio	III Bauart Model	V Befestigungs- Mounting Side	VI Einbaulage Mounting Config.	IV Drehzahl n2max Speed n2max	Ausführung Design
VLM	200	5:1	A0	-	1	-	300 / 0000=Standard
II Motorausführung Motor features	Polzahl No. of Poles	Zusatzausführung Additional features	Klemmenkastenlage (Getriebeseite) Position of terminal box (gear site)				
DS 132 S	-	4	/	00	-		5

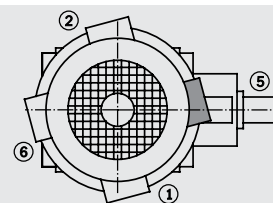

Typ VLM 200

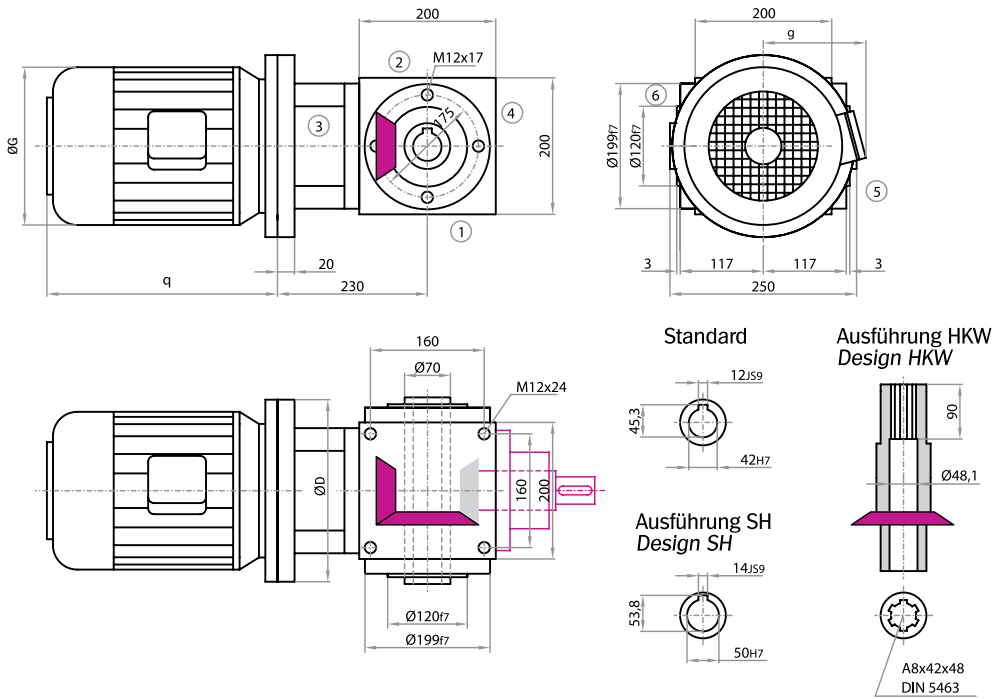

Achtung: Standardbefestigungsgewinde im Gehäuse nur an den Seiten 1, 2 & 4. Alternativ auch an den Seiten 5 & 6 möglich.
Note: Standard fastening thread in the housing only on sides 1, 2 & 4. Alternatively, also possible on sides 5 & 6.

Bauart / Model

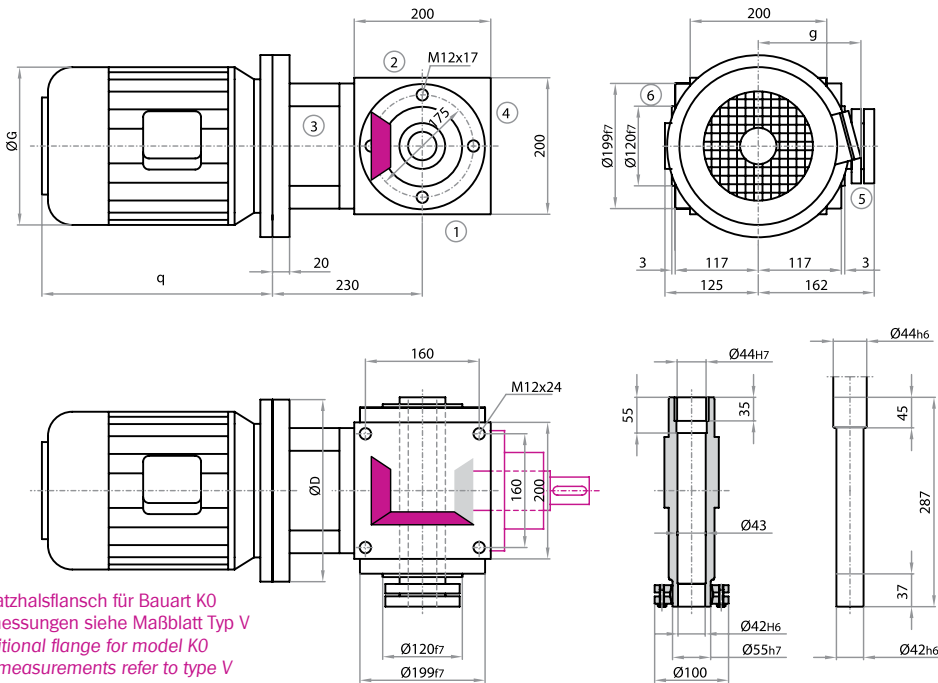
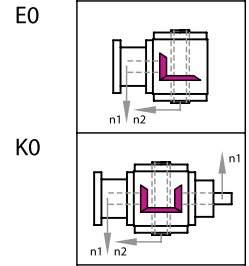

Zusatzflansch für Bauart K0
 Abmessungen siehe Maßblatt Typ V
 Additional flange for model K0
 For measurements refer to type V

Achtung: Standardbefestigungsgewinde im Gehäuse nur an den Seiten 1, 2 & 4. Alternativ auch an den Seiten 5 & 6 möglich.
Note: Standard fastening thread in the housing only on sides 1, 2 & 4. Alternatively, also possible on sides 5 & 6.

Bauart / Model

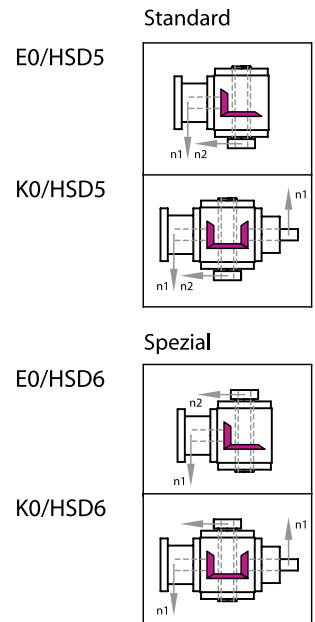

Abmessungen / Measurements

*q1=Bremmotoren / brake motors

Baugröße / size	Motorabmessungen / Motor Dimensions					q1*
	D	G	g	q		
100/112	200	210	155	301	348	
132S	200	260	200	390	428	
132M	200	260	200	416	454	
160	250	320	245	540		
180	250	320	245	580		

IV Leistungen, Drehmomente / Power Ratings, Torque Ratings

P1 kW	n2 1/min	T2 Nm	T2N Nm	T2max Nm	i	Motor
4,0	177,0	204,5	510,0	860,0	4,0	160MA-8
	142,0	255,6	440,0	860,0	5,0	160MA-8
5,5	238,0	209,4	580,0	910,0	3,0	160LA-8
	190,0	262,6	420,0	860,0	5,0	132MB-6
	178,0	279,2	510,0	860,0	4,0	160LA-8
	143,0	348,9	440,0	860,0	5,0	160LA-8
7,5	640,0	106,3	505,0	600,0	1,5	160MB-6
	480,0	141,8	500,0	530,0	2,0	160MB-6
	320,0	212,6	555,0	910,0	3,0	160MB-6
	286,0	237,9	380,0	860,0	5,0	132MB-4
	240,0	283,5	485,0	860,0	4,0	160MB-6
	192,0	354,4	420,0	860,0	5,0	160MB-6
	180,0	378,0	510,0	860,0	4,0	160LB-8
9,0	286,0	285,5	380,0	860,0	5,0	132MC-4
11,0	1940,0	51,4	330,0	600,0	1,5	160MA-2
	1465,0	68,1	450,0	1090,0	1,0	160MB-4
	976,0	102,2	437,0	600,0	1,5	160MB-4
	732,0	136,2	425,0	530,0	2,0	160MB-4
	640,0	155,9	505,0	600,0	1,5	160LA-6
	582,0	171,5	300,0	860,0	5,0	160MA-2
	488,0	204,4	515,0	910,0	3,0	160MB-4
	366,0	272,5	455,0	860,0	4,0	160MB-4
	320,0	311,9	555,0	910,0	3,0	160LA-6

P1 kW	n2 1/min	T2 Nm	T2N Nm	T2max Nm	i	Motor	
11,0	293,0	340,6	380,0	860,0	5,0	160MB-4	
	240,0	415,8	485,0	860,0	4,0	160LA-6	
15,0	1953,0	69,7	330,0	600,0	1,5	160MB-2	
	1465,0	92,9	450,0	1090,0	1,0	160LA-4	
	976,0	139,3	437,0	600,0	1,5	160LA-4	
	732,0	185,8	425,0	530,0	2,0	160LA-4	
	646,0	210,4	505,0	600,0	1,5	180L-6	
	586,0	232,2	300,0	860,0	5,0	160MB-2	
	488,0	278,7	515,0	910,0	3,0	160LA-4	
	366,0	371,6	455,0	860,0	4,0	160LA-4	
	323,0	420,9	555,0	910,0	3,0	180L-6	
	18,5	1960,0	85,6	330,0	600,0	1,5	160L-2
1470,0		114,2	450,0	1090,0	1,0	180M-4	
980,0		171,3	437,0	600,0	1,5	180M-4	
735,0		228,4	425,0	530,0	2,0	180M-4	
588,0		285,4	300,0	860,0	5,0	160L-2	
490,0		342,5	515,0	910,0	3,0	180M-4	
367,0		456,7	455,0	860,0	4,0	180M-4	
22,0		1470,0	135,8	450,0	1090,0	1,0	180L-4
		980,0	203,7	437,0	600,0	1,5	180L-4
		735,0	271,6	425,0	530,0	2,0	180L-4
	490,0	407,3	515,0	910,0	3,0	180L-4	

Radialkräfte / Radial Forces (N)

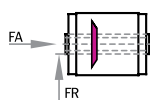

T2 Nm	n2 (1/min)					
	3000	1000	500	250	100	50
< 500	3600	4700	5400	7200	9000	11000
> 500	3000	3900	4500	6000	7500	9200

Weitere Erläuterungen und verstärkte Lagerungen siehe Allgemeines / For more information and reinforced bearings, refer to general Information.
 Axialkräfte FA = 50% der Radialkräfte - siehe Allgemeines / Axial forces FA = 50% of radial forces - refer to general information.

**Massenträgheitsmomente und Getriebegewichte auf Anfrage.
 Moments of Inertia and gearbox weights available on request.**

V Befestigungsseite / Mounting Side

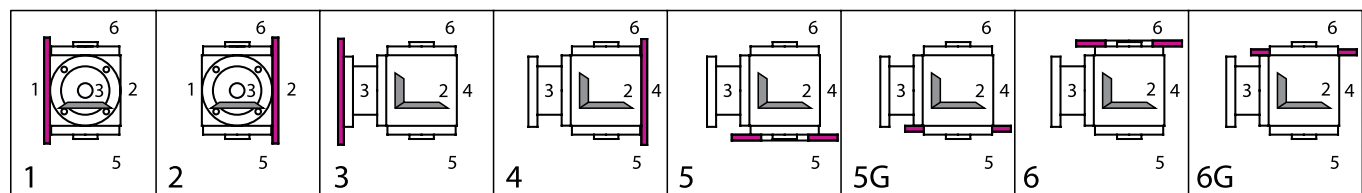

VI Einbaulagen (unten liegende Getriebeseite) / Mounting Configuration (downward-facing side)

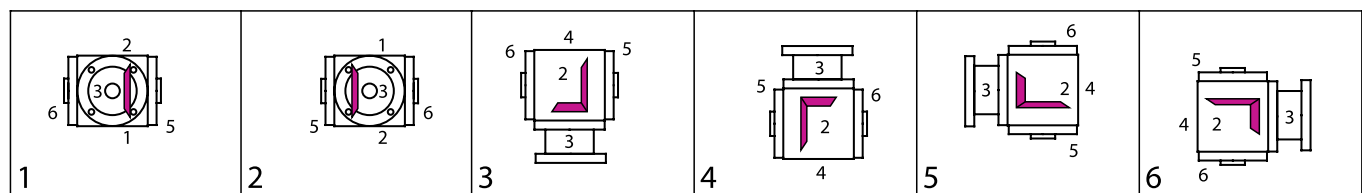

Bestellbeispiel / Example of Order

I Typ	Größe Size	IV Übersetzung Ratio	III Bauart Model	V Befestigungs- Mounting Side	VI Einbaulage Mounting Config.	IV Drehzahl n2max Speed n2max	Ausführung Design
VLM	200	5:1	E0	-	1	-	300 / 0000=Standard
II Motorausführung Motor features	Polzahl No. of Poles		Zusatzausführung Additional features		Klemmenkastenlage (Getriebeseite) Position of terminal box (gear site)		
DS 132 S	-	4	/	00	-	5	

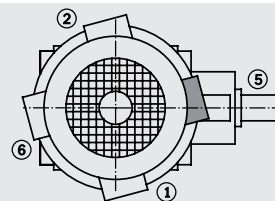

Typ VLM 230

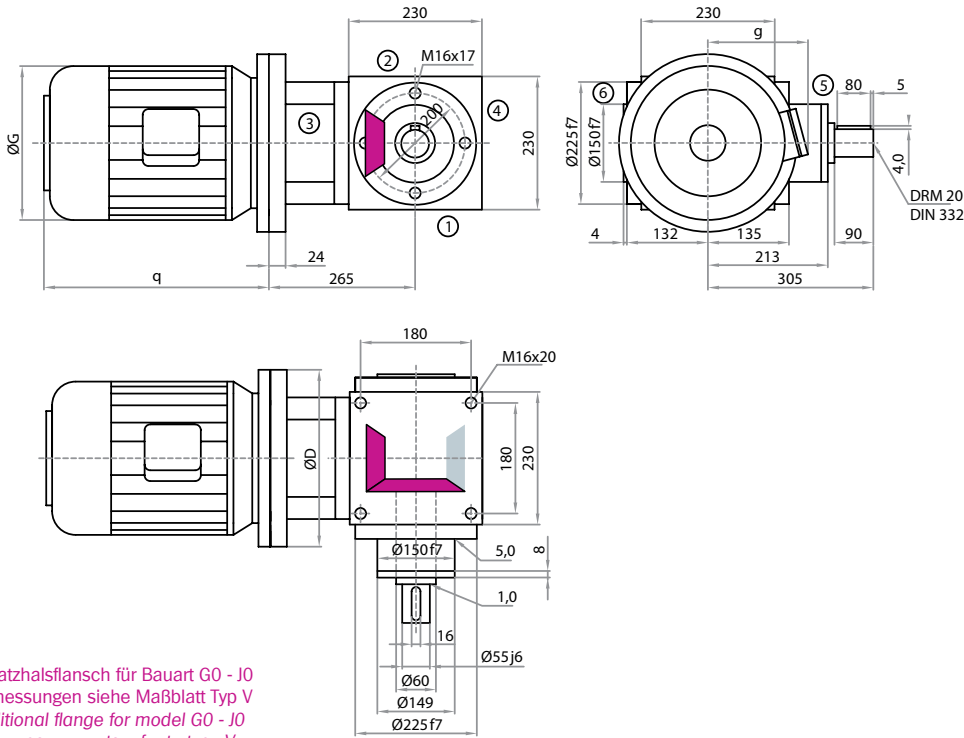

Zusatzhalsflansch für Bauart G0 - J0
Abmessungen siehe Maßblatt Typ V
Additional flange for model G0 - J0
For measurements refer to type V

Achtung: Standardbefestigungsgewinde im Gehäuse nur an den Seiten 1, 2 & 4. Alternativ auch an den Seiten 5 & 6 möglich.
Note: Standard fastening thread in the housing only on sides 1, 2 & 4. Alternatively, also possible on sides 5 & 6.

Bauart / Model

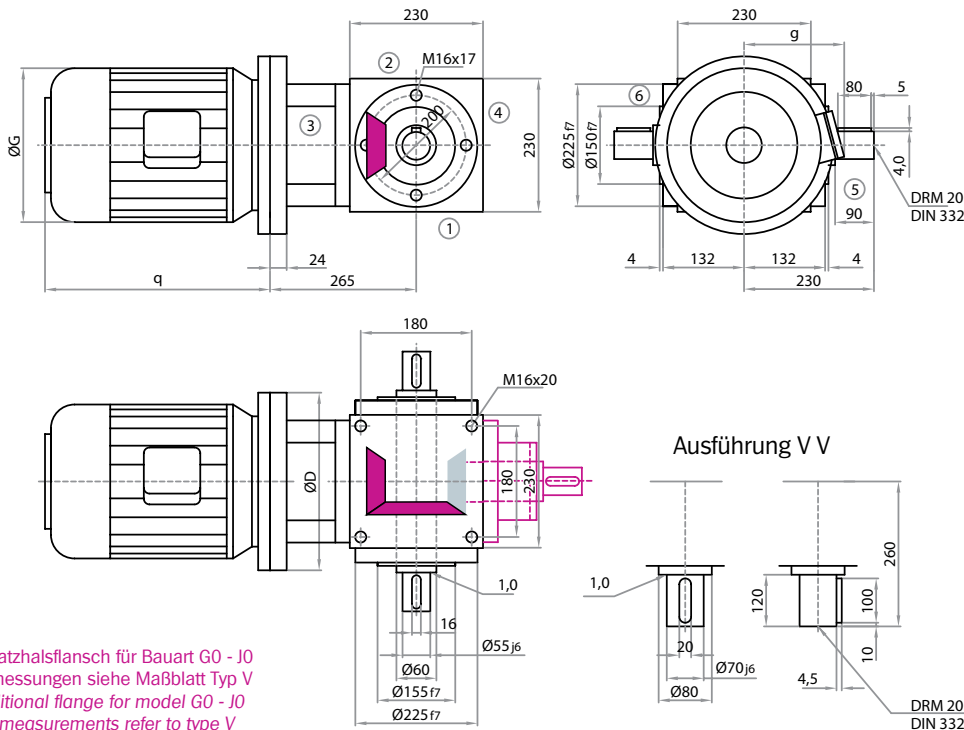
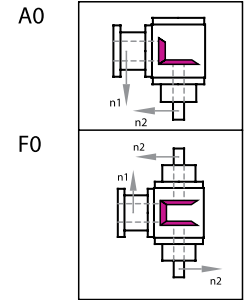

Zusatzhalsflansch für Bauart G0 - J0
Abmessungen siehe Maßblatt Typ V
Additional flange for model G0 - J0
For measurements refer to type V

Achtung: Standardbefestigungsgewinde im Gehäuse nur an den Seiten 1, 2 & 4. Alternativ auch an den Seiten 5 & 6 möglich.
Note: Standard fastening thread in the housing only on sides 1, 2 & 4. Alternatively, also possible on sides 5 & 6.

B0

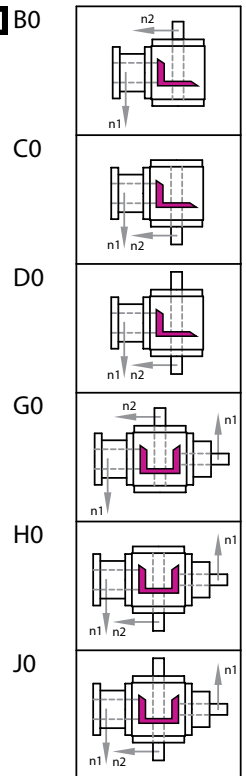

Abmessungen / Measurements

*q1=Bremsmotoren / brake motors

Baugröße / Size	Motorabmessungen / Motor Dimensions				
	D	G	g	q	q1*
132S	300	260	200	390	428
132M	300	260	200	416	454
160	350	320	245	540	
180	350	320	245	580	
200	400	360	275	640	

IV Leistungen, Drehmomente / Power Ratings, Torque Ratings

P1 kW	n2 1/min	T2 Nm	T2N Nm	T2max Nm	i	Motor
5,5	119	418,73	565	1000	6	160LA-8
7,5	144	472,53	770	1200	5	160LB-8
	160	425,27	540	1000	6	160MB-6
9	238	342,59	490	1000	6	132MC-4
11	192	519,78	770	1200	5	160LA-6
	182	546,84	735	1300	4	180L-8
15	242	561,18	675	1300	4	180L-6
	293	464,46	635	1200	5	160LA-4
	488	278,67	366	1000	6	160MB-2

P1 kW	n2 1/min	T2 Nm	T2N Nm	T2max Nm	i	Motor
18,5	294	570,88	635	1200	5	180M-4
	325	516,43	635	1300	3	200LA-6
	490	342,53	366	1000	6	160L-2
22	367	543,12	600	1300	4	180L-4
	590	338,29	510	1200	5	180M-2
30	737	369,05	440	1300	4	200L-2

Radialkräfte / Radial Forces (N)

FA	FR	T2 Nm	n2 (1/min)						FA	FR	T2 Nm	n2 (1/min)					
			3000	1000	500	250	100	50				3000	1000	500	250	100	50
< 750		4600	5150	7200	9450	11250	13100			5850	8650	10500	12250	15000	19000		
> 750		3830	4290	6000	7870	9370	10920			4870	7210	8750	10210	12500	15830		

Weitere Erläuterungen und verstärkte Lagerungen siehe Allgemeines / For more information and reinforced bearings, refer to general information.
 Axialkräfte FA = 50% der Radialkräfte - siehe Allgemeines / Axial forces FA = 50% of radial forces - refer to general information.

Massenträgheitsmomente und Getriebegewichte auf Anfrage. Moments of Inertia and gearbox weights available on request.

V Befestigungsseite / Mounting Side

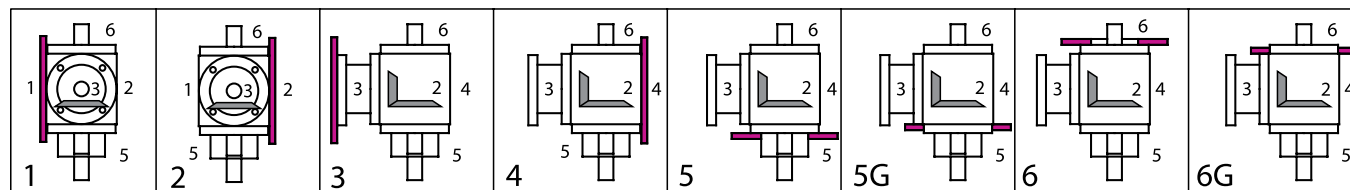

VI Einbaulagen (unten liegende Getriebeseite) / Mounting Configuration (downward-facing side)

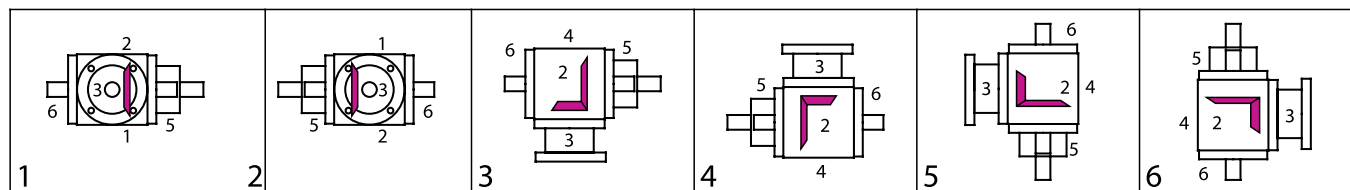

Bestellbeispiel / Example of Order

I Typ	Größe Size	IV Übersetzung Ratio	III Bauart Model	V Befestigungs- Mounting Side	VI Einbaulage Mounting Config.	IV Drehzahl n2max Speed n2max	Ausführung Design
VLM	230	5:1	A0	1	1	300	0000=Standard
III Motorausführung Motor features	DS 132 S	Polzahl No. of Poles	4	Zusatzausführung Additional features	/	Klemmenkastenlage (Getriebeseite) Position of terminal box (gear site)	5

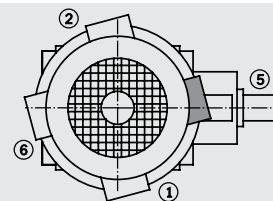

Kegelradgetriebe Typ V
Bevel Gearboxes Type V

Typ VLM 230

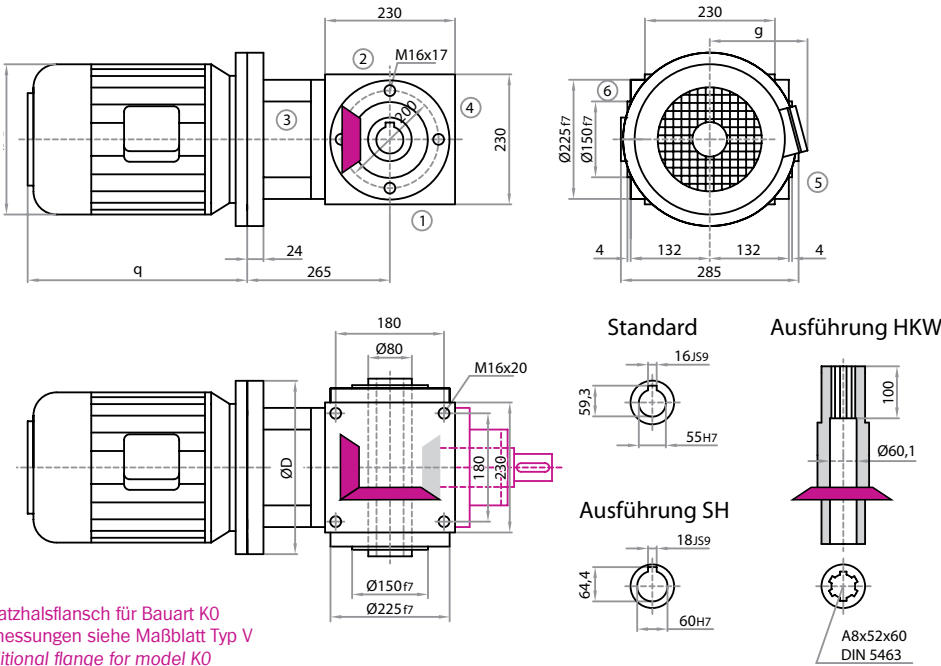

Zusatzflansch für Bauart K0
Abmessungen siehe Maßblatt Typ V
Additional flange for model K0
For measurements refer to type V

Achtung: Standardbefestigungsgewinde im Gehäuse nur an den Seiten 1, 2 & 4. Alternativ auch an den Seiten 5 & 6 möglich.
Note: Standard fastening thread in the housing only on sides 1, 2 & 4. Alternatively, also possible on sides 5 & 6.

Bauart / Model

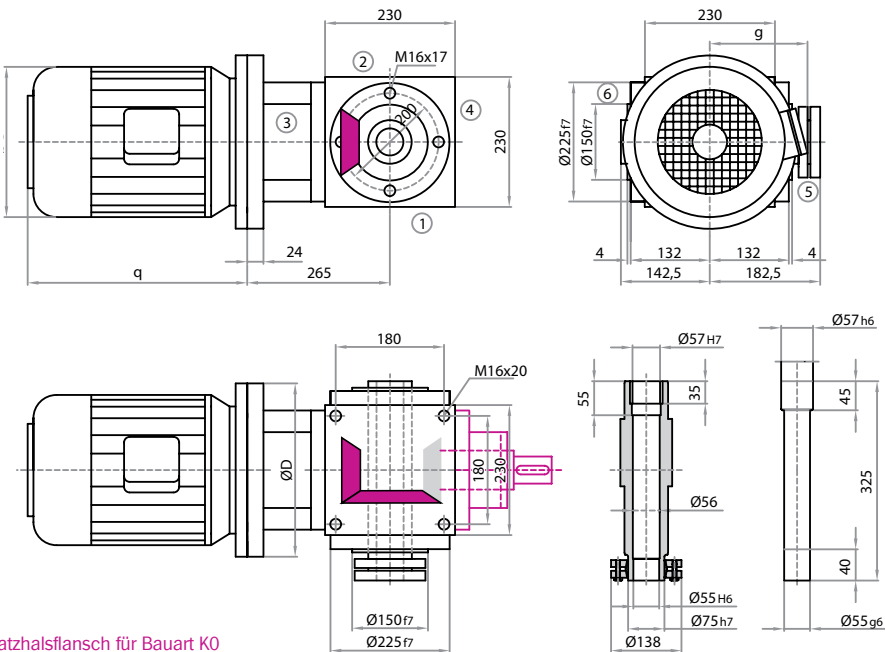
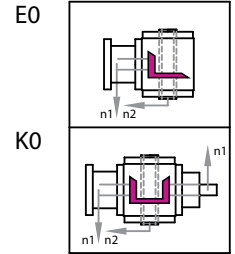

Zusatzflansch für Bauart K0
Abmessungen siehe Maßblatt Typ V
Additional flange for model K0
For measurements refer to type V

Achtung: Standardbefestigungsgewinde im Gehäuse nur an den Seiten 1, 2 & 4. Alternativ auch an den Seiten 5 & 6 möglich.
Note: Standard fastening thread in the housing only on sides 1, 2 & 4. Alternatively, also possible on sides 5 & 6.

Bauart / Model

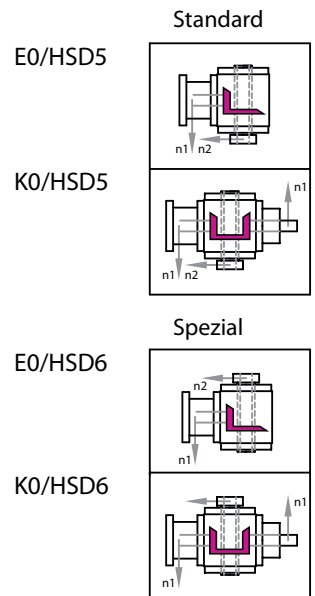

Abmessungen / Measurements

*q1=Bremstromotoren / brake motors

Baugröße / size	Motorabmessungen / Motor Dimensions				
	D	G	g	q	q1*
132S	300	260	200	390	428
132M	300	260	200	416	454
160	350	320	245	540	
180	350	320	245	580	
200	400	360	275	640	

IV Leistungen, Drehmomente / Power Ratings, Torque Ratings

P1 kW	n2 1/min	T2 Nm	T2N Nm	T2max Nm	i	Motor
5,5	119	418,73	565	1000	6	160LA-8
7,5	144	472,53	770	1200	5	160LB-8
	160	425,27	540	1000	6	160MB-6
9	238	342,59	490	1000	6	132MC-4
11	192	519,78	770	1200	5	160LA-6
	182	546,84	735	1300	4	180L-8
15	242	561,18	675	1300	4	180L-6
	293	464,46	635	1200	5	160LA-4
	488	278,67	366	1000	6	160MB-2

P1 kW	n2 1/min	T2 Nm	T2N Nm	T2max Nm	i	Motor
18,5	294	570,88	635	1200	5	180M-4
	325	516,43	635	1300	3	200LA-6
	490	342,53	366	1000	6	160L-2
22	367	543,12	600	1300	4	180L-4
	590	338,29	510	1200	5	180M-2
30	737	369,05	440	1300	4	200L-2

Radialkräfte / Radial Forces (N)

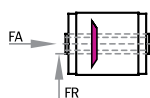

T2 Nm	n2 (1/min)
< 750	500
> 750	50

Weitere Erläuterungen und verstärkte Lagerungen siehe Allgemeines / For more information and reinforced bearings, refer to general information.
 Axialkräfte FA = 50% der Radialkräfte - siehe Allgemeines / Axial forces FA = 50% of radial forces - refer to general information.

Massenträgheitsmomente und Getriebegewichte auf Anfrage. Moments of Inertia and gearbox weights available on request.

V Befestigungsseite / Mounting Side

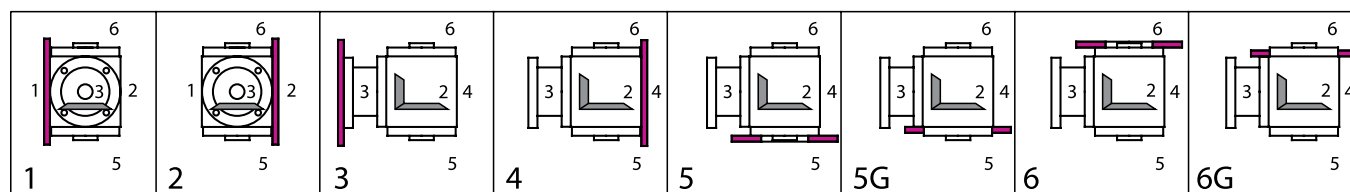

VI Einbaulagen (unten liegende Getriebeseite) / Mounting Configuration (downward-facing side)

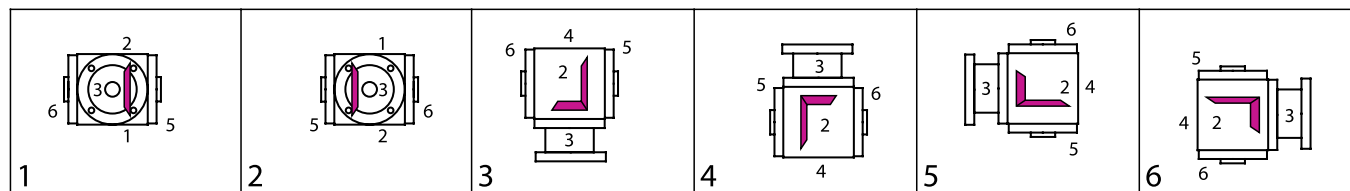

Bestellbeispiel / Example of Order

I Typ	Größe Size	IV Übersetzung Ratio	III Bauart Model	V Befestigungs- Mounting Side	VI Einbaulage Mounting Config.	IV Drehzahl n2max Speed n2max	Ausführung Design
VLM	230	5:1	E0	1	1	300	0000=Standard
III Motorausführung Motor features	Polzahl No. of Poles	Zusatzausführung Additional features	Klemmenkastenlage (Getriebeseite) Position of terminal box (gear site)				
DS 132 S	4	/ 00	5				

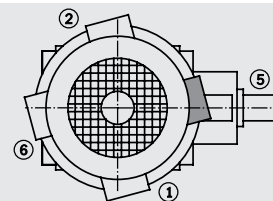

Kegelradgetriebe Typ V
Bevel Gearboxes Type V

Typ VLM 260

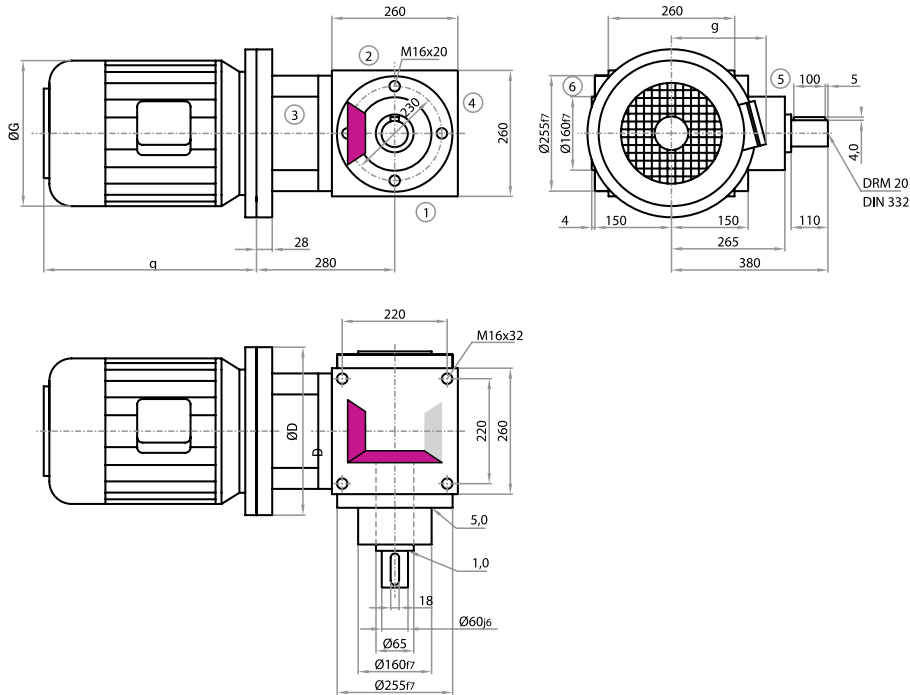

Bauart / Model

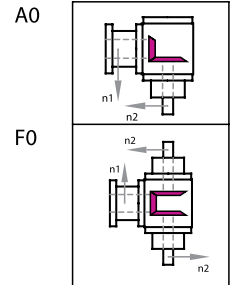

Achtung: Standardbefestigungsgewinde im Gehäuse nur an den Seiten 1, 2 & 4. Alternativ auch an den Seiten 5 & 6 möglich.
Note: Standard fastening thread in the housing only on sides 1, 2 & 4. Alternatively, also possible on sides 5 & 6.

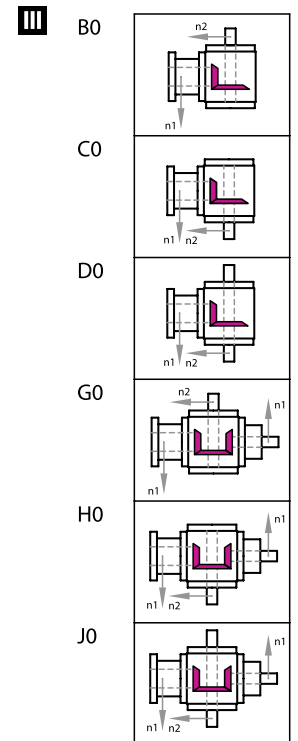
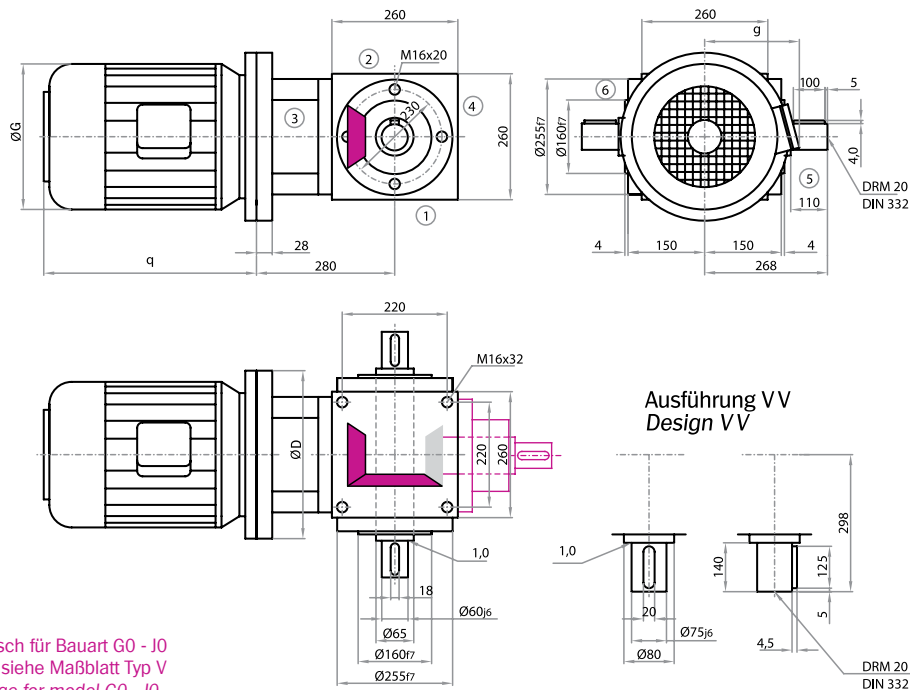

Zusatzhalsflansch für Bauart G0 - J0
 Abmessungen siehe Maßblatt Typ V
 Additional flange for model G0 - J0
 For measurements refer to type V

Achtung: Standardbefestigungsgewinde im Gehäuse nur an den Seiten 1, 2 & 4. Alternativ auch an den Seiten 5 & 6 möglich.
Note: Standard fastening thread in the housing only on sides 1, 2 & 4. Alternatively, also possible on sides 5 & 6.

Abmessungen / Measurements

*q1=Bremstromotoren / brake motors

Baugröße / Size	Motorabmessungen / Motor Dimensions					q1*
	D	G	g	q		
132S	300	260	200	390	428	
132M	300	260	200	416	454	
160	350	320	145	540		
180	350	320	145	580		
200	400	360	275	640		

IV Leistungen, Drehmomente / Power Ratings, Torque Ratings

P1 kW	n2 1/min	T2 Nm	T2N Nm	T2max Nm	i	Motor
7,5	144,0	472,5	1100,0	1910,0	5,0	160LB-8
11,0	192,0	519,8	990,0	1910,0	5,0	160LA-6
	182,0	546,8	1100,0	1940,0	4,0	180L-8
	146,0	683,5	1100,0	1910,0	5,0	180L-8
15,0	293,0	464,5	880,0	1910,0	5,0	160LA-4
	242,0	561,2	1050,0	1940,0	4,0	180L-6
	194,0	701,5	990,0	1910,0	5,0	180L-6
	182,0	745,7	1100,0	1940,0	4,0	200LB-8
	146,0	932,1	1100,0	1910,0	5,0	200LB-8
18,5	975,0	172,1	1050,0	2310,0	1,0	200LA-6
	650,0	258,2	1000,0	1000,0	1,5	200LA-6
	325,0	516,4	990,0	1940,0	3,0	200LA-6
	294,0	570,9	880,0	1910,0	5,0	180M-4

P1 kW	n2 1/min	T2 Nm	T2N Nm	T2max Nm	i	Motor
18,5	243,0	688,6	1050,0	1940,0	4,0	200LA-6
	195,0	860,7	990,0	1910,0	5,0	200LA-6
22,0	650,0	307,1	1000,0	1000,0	1,5	200LB-6
	487,0	409,4	1050,0	1200,0	2,0	200LB-6
	367,0	543,1	900,0	1940,0	4,0	180L-4
	325,0	614,1	990,0	1940,0	3,0	200LB-6
	294,0	678,9	880,0	1910,0	5,0	180L-4
	243,0	818,9	1050,0	1940,0	4,0	200LB-6
30,0	1470,0	185,2	950,0	2310,0	1,0	200LB-4
	980,0	277,7	950,0	1000,0	1,5	200LB-4
	735,0	370,3	950,0	1200,0	2,0	200LB-4
	490,0	555,5	900,0	1940,0	3,0	200LB-4
	367,0	740,6	900,0	1940,0	4,0	200LB-4

Radialkräfte / Radial Forces (N)

T2 Nm	n2 (1/min)					
	3000	1000	500	250	100	50
< 950	7000	8600	11200	15000	17500	20000
> 950	5830	7170	9330	12500	14580	16670

Weitere Erläuterungen und verstärkte Lagerungen siehe Allgemeines / For more information and reinforced bearings, refer to general Information.
 Axialkräfte FA = 50% der Radialkräfte - siehe Allgemeines / Axial forces FA = 50% of radial forces - refer to general information.

**Massenträgheitsmomente und Getriebegewichte auf Anfrage.
 Moments of Inertia and gearbox weights available on request.**

V Befestigungsseite / Mounting Side

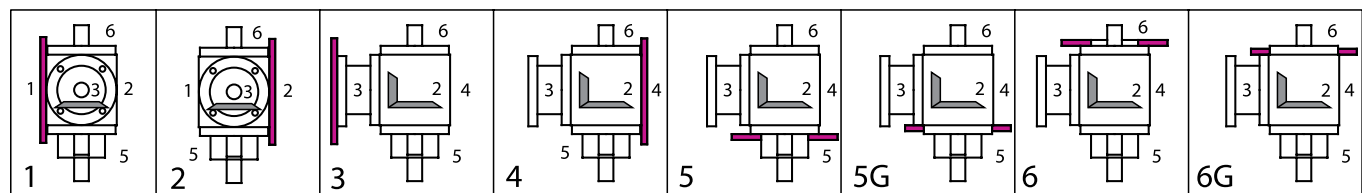

VI Einbaulagen (unten liegende Getriebeseite) / Mounting Configuration (downward-facing side)

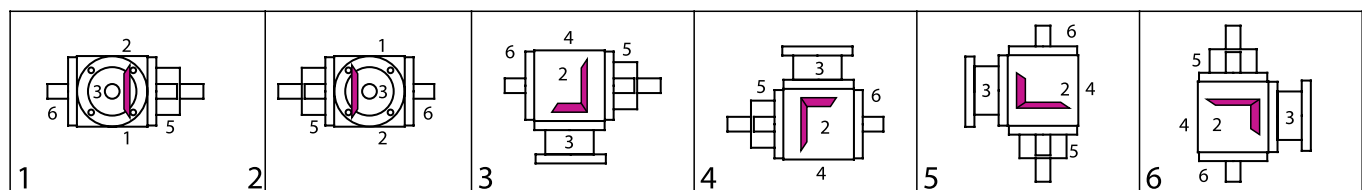

Bestellbeispiel / Example of Order

I Typ	Größe	IV Übersetzung	III Bauart	V Befestigungs-	VI Einbaulage	IV Drehzahl n2max	Ausführung
VLM	260	5:1	A0	-	1	-	200 / 0000=Standard
III Motorausführung	Polzahl		Zusatzausführung		Klemmenkastenlage (Getriebeseite)		
Motor features	No. of Poles		Additional features		Position of terminal box (gear site)		
DS 132 S	6		/ 00		5		

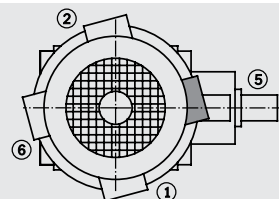

Kegelradgetriebe Typ V
Bevel Gearboxes Type V

Typ VLM 260

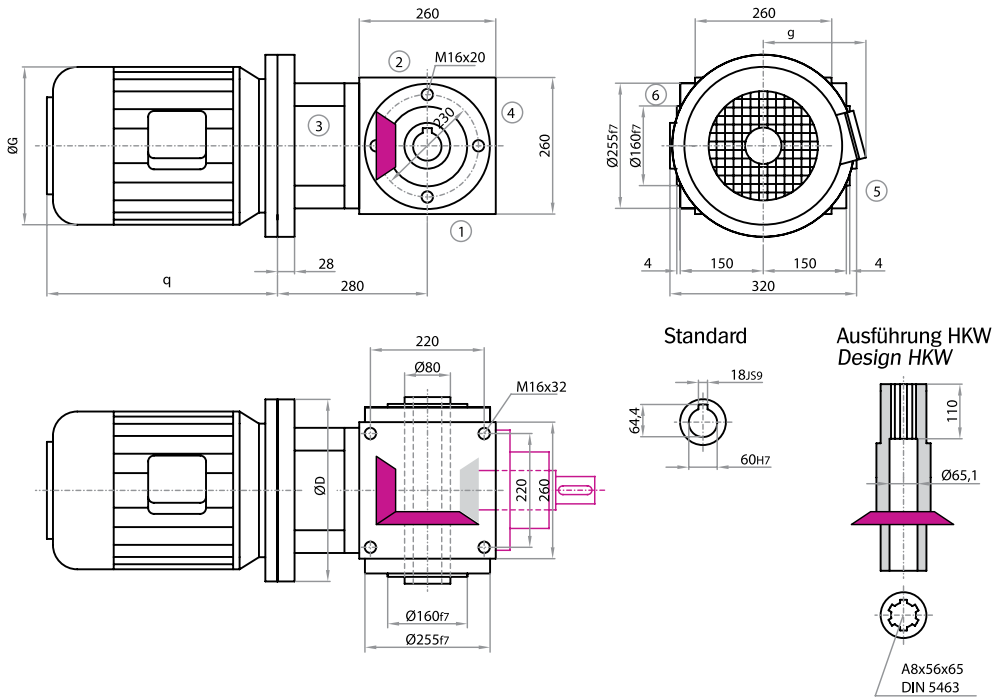

Achtung: Standardbefestigungsgewinde im Gehäuse nur an den Seiten 1, 2 & 4. Alternativ auch an den Seiten 5 & 6 möglich.
Note: Standard fastening thread in the housing only on sides 1, 2 & 4. Alternatively, also possible on sides 5 & 6.

Bauart / Model

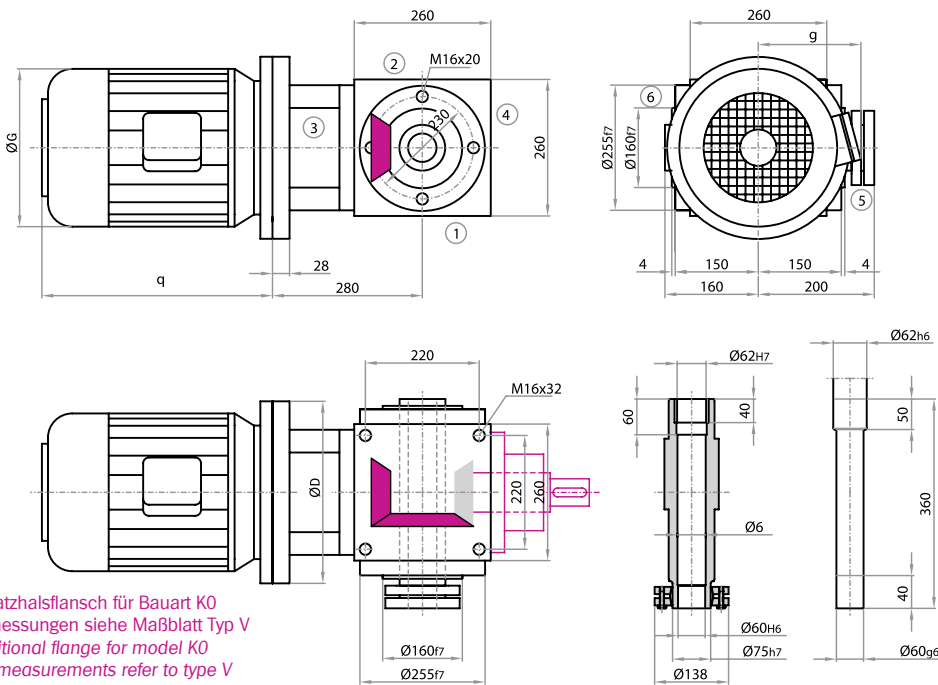
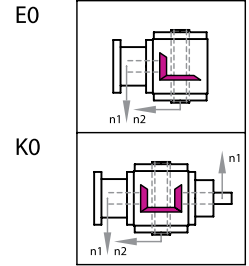

Zusatzflansch für Bauart K0
 Abmessungen siehe Maßblatt Typ V
 Additional flange for model K0
 For measurements refer to type V

Achtung: Standardbefestigungsgewinde im Gehäuse nur an den Seiten 1, 2 & 4. Alternativ auch an den Seiten 5 & 6 möglich.
Note: Standard fastening thread in the housing only on sides 1, 2 & 4. Alternatively, also possible on sides 5 & 6.

Bauart / Model

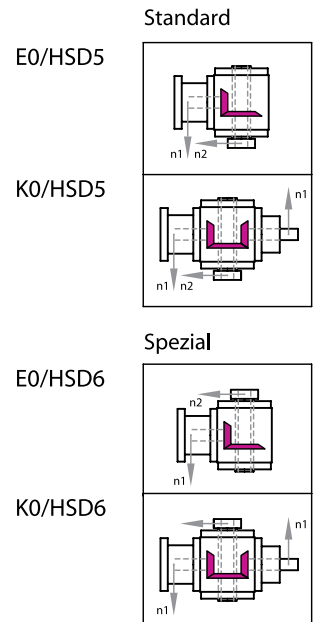

Abmessungen / Measurements

*q1=Bremmotoren / brake motors

Baugröße / Size	Motorabmessungen / Motor Dimensions				
	D	G	g	q	q1*
132S	300	260	200	390	428
132M	300	260	200	416	454
160	350	320	145	540	
180	350	320	145	580	
200	400	360	275	640	

IV Leistungen, Drehmomente / Power Ratings, Torque Ratings

P1 kW	n2 1/min	T2 Nm	T2N Nm	T2max Nm	i	Motor
7,5	144,0	472,5	1100,0	1910,0	5,0	160LB-8
11,0	192,0	519,8	990,0	1910,0	5,0	160LA-6
	182,0	546,8	1100,0	1940,0	4,0	180L-8
	146,0	683,5	1100,0	1910,0	5,0	180L-8
15,0	293,0	464,5	880,0	1910,0	5,0	160LA-4
	242,0	561,2	1050,0	1940,0	4,0	180L-6
	194,0	701,5	990,0	1910,0	5,0	180L-6
	182,0	745,7	1100,0	1940,0	4,0	200LB-8
	146,0	932,1	1100,0	1910,0	5,0	200LB-8
18,5	975,0	172,1	1050,0	2310,0	1,0	200LA-6
	650,0	258,2	1000,0	1000,0	1,5	200LA-6
	325,0	516,4	990,0	1940,0	3,0	200LA-6
	294,0	570,9	880,0	1910,0	5,0	180M-4

P1 kW	n2 1/min	T2 Nm	T2N Nm	T2max Nm	i	Motor
18,5	243,0	688,6	1050,0	1940,0	4,0	200LA-6
	195,0	860,7	990,0	1910,0	5,0	200LA-6
22,0	650,0	307,1	1000,0	1000,0	1,5	200LB-6
	487,0	409,4	1050,0	1200,0	2,0	200LB-6
	367,0	543,1	900,0	1940,0	4,0	180L-4
	325,0	614,1	990,0	1940,0	3,0	200LB-6
	294,0	678,9	880,0	1910,0	5,0	180L-4
	243,0	818,9	1050,0	1940,0	4,0	200LB-6
30,0	1470,0	185,2	950,0	2310,0	1,0	200LB-4
	980,0	277,7	950,0	1000,0	1,5	200LB-4
	735,0	370,3	950,0	1200,0	2,0	200LB-4
	490,0	555,5	900,0	1940,0	3,0	200LB-4
	367,0	740,6	900,0	1940,0	4,0	200LB-4

Radialkräfte / Radial Forces (N)

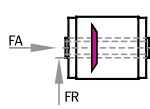

T Nm	n 1/min					
	3000	1000	500	250	100	50
< 950	8500	13000	16000	18000	22000	28000
> 950	7080	10830	13330	15000	18330	23330

Weitere Erläuterungen und verstärkte Lagerungen siehe Allgemeines / For more information and reinforced bearings, refer to general information.
 Axialkräfte FA = 50% der Radialkräfte - siehe Allgemeines / Axial forces FA = 50% of radial forces - refer to general information.

**Massenträgheitsmomente und Getriebegewichte auf Anfrage.
 Moments of Inertia and gearbox weights available on request.**

V Befestigungsseite / Mounting Side

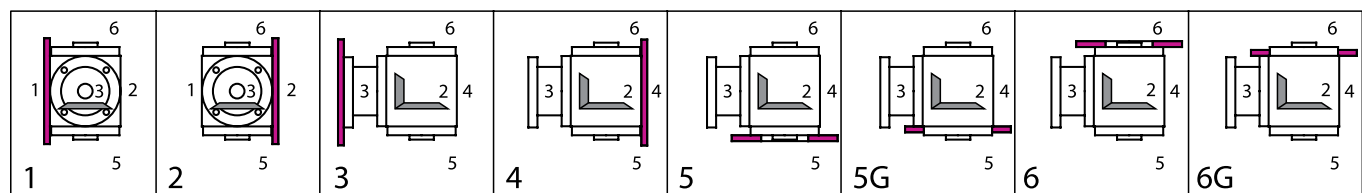

VI Einbaulagen (unten liegende Getriebeseite) / Mounting Configuration (downward-facing side)

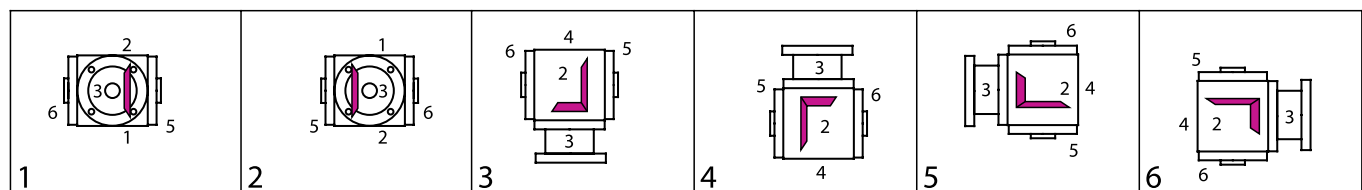

Bestellbeispiel / Example of Order

I Typ	Größe Size	IV Übersetzung Ratio	III Bauart Model	V Befestigungs- Mounting Side	VI Einbaulage Mounting Config.	IV Drehzahl n2max Speed n2max	Ausführung Design
VLM	260	5:1	A0	1	1	200 / 0000=Standard	
III Motorausführung Motor features	Polzahl No. of Poles	Zusatzausführung Additional features			Klemmenkastenlage (Getriebeseite) Position of terminal box (gear site)		
DS 132 S	6	/ 00			5		

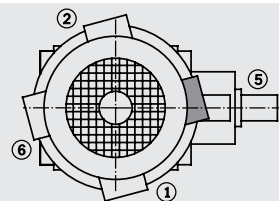

Abzweiggetriebe / Multi Shaft Gearboxes

Abzweiggetriebe

Das Baukastensystem unserer Kegelradgetriebe macht es möglich, eine Vielzahl von Bauart-Variationen herzustellen. Die Abmessungen entsprechen den Normalbauarten. Außer $i=1:1$ sind alle Übersetzungen lieferbar. (Ausnahme: Bauart F2 ist auch in $i=1:1$ lieferbar!)

Multi-Shaft Gearboxes

The modular construction of our bevel gearboxes makes it possible to produce a wide range of design variants. The dimensions are the same as those of the standard versions. With the exception of $i=1:1$, all transmission ratios are available. (Exception: model F2 is also available in $i=1:1$!)

Typ/Type V		Typ/Type VS		
A1 		B1 		
F1 		C1 		
F2 		D1 		
F3 		H1 		

Typ/Type V		Typ/Type VS		
		<p>H2</p>		
<p>F4</p>		<p>G1</p>		
<p>E1</p>		<p>G2</p>		
<p>K1</p>		<p>J1</p>		
<p>K2</p>		<p>J2</p>		

■ Leistung ist unser Antrieb

Performance is our drive

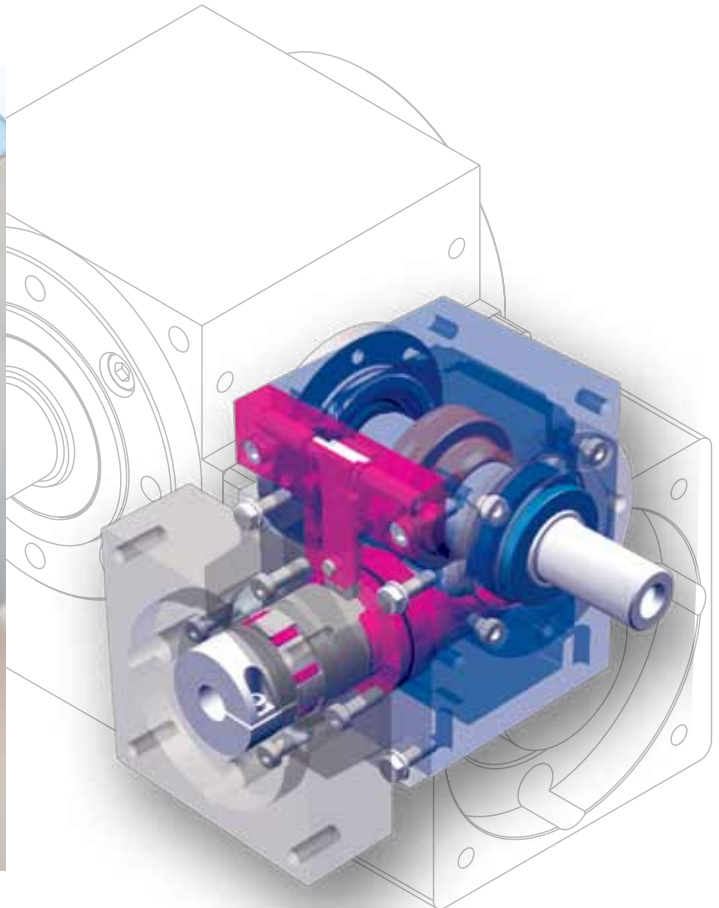

ATEK – der Spezialist für rechtwinklige Kraftübertragung

In mehr als 25 Jahren Getriebebau hat sich ATEK mit Kegelrad- und Schneckengetrieben weltweit einen hervorragenden Ruf erarbeitet. Unsere innovativen Technologien stehen für höchste Qualität, hohe Präzision, fundiertes Know-how und ein hervorragendes Preis-/Leistungsverhältnis. Unsere Produkte setzen Maßstäbe in puncto Zuverlässigkeit, Dynamik, Spiel- und Wartungsarmut sowie einfacher Handhabung. Überall dort, wo Drehmomente im rechten Winkel übertragen werden, sich verzweigen und gleichzeitig höchste Anforderungen bezüglich einer spielarmen Ausführung gestellt werden, ist ATEK der ideale Partner.

Unsere Winkelgetriebe zeichnen sich durch eine kompakte Bauform, ein großes Leistungsspektrum und eine Vielzahl möglicher Übersetzungen aus. Ob als Leistungsantrieb in einer Förderanlage oder Steuerantrieb in hochdynamischen Werkzeugmaschinen – für nahezu jeden Anwendungsfall bietet ATEK die maßgeschneiderte Lösung. Im Interesse unserer Kunden konzentrieren wir uns auf die Kernfelder Produktentwicklung, Qualitätssicherung und Montage.

Die Fertigung unserer Produkte übernehmen ausgewählte, hochspezialisierte Zulieferfirmen, die nach unseren Vorgaben in optimierten Losgrößen und modernsten Fertigungszentren produzieren. Damit bieten wir Ihnen Produkte auf dem neuesten Stand der Technik mit einem Maximum an Qualität und Flexibilität – zu attraktiven Preisen.

ATEK – The Experts for Right-Angle Power Transmission

With more than 25 years of experience in transmission manufacturing, ATEK has earned an excellent reputation worldwide with its bevel gear and worm gear units. Our innovative technologies stand for maximum quality, high precision, solid know-how and an outstanding cost-performance ratio. Our products set standards for reliability, dynamics, minimal slackness and maintenance, and ease of operation.

Wherever torque transfer is needed at right angles or branches while maintaining minimal slackness, ATEK is the ideal partner.

Our angular gears feature a compact design, a high power spectrum and a variety of different transmission ratios. Whether you need a power drive in a conveyor system or a control drive in highly dynamic machine tools – ATEK can provide a customized solution for almost any application. In the interest of our customers, we focus on the core areas of product development, quality assurance and installation.

Our products are manufactured by selected, highly specialized subcontractors according to our specifications in optimized batch sizes at ultra-modern production centers. Therefore, we provide you with state-of-the-art products of maximum quality and flexibility – at competitive prices.

Überzeugende Argumente

Convincing Arguments

partnerschaftlich und kompetent:

Zu unseren Kunden pflegen wir langfristige Partnerschaften. Loyalität, Vertrauen und enge Zusammenarbeit stehen hier an erster Stelle. Die umfassende, kompetente Kundenbetreuung und -beratung – von ersten Anfragen über die Auslieferung und Montage bis hin zur Unterstützung bei Wartungsfragen – genießt bei ATEK höchste Priorität. Mit gezielten Informationen und Rückmeldungen können Sie als unser Kunde und Partner dazu beitragen, dass wir auch zukünftig Ihren Wünschen und Anforderungen bestmöglich entsprechen.

kundenspezifisch und qualitativ hochwertig:

Wie Ihre individuellen Anforderungen auch lauten, ATEK bietet für nahezu jeden Anwendungsfall die maßgeschneiderte Lösung – mit modernsten Technologien gefertigt und zu einem äußerst attraktiven Preis. Unser nach DIN ISO 9001 zertifiziertes Qualitätsmanagementsystem sichert zudem unser Qualitätsbewusstsein und trägt zur ständigen Kontrolle und Optimierung unserer Abläufe bei.

komplett sortiert – fertig montiert:

ATEK bietet Ihnen alles, was Sie im Bereich rechtwinkliger Kraftübertragung benötigen. Aus großen Fertigteillagern montieren unsere fachkompetenten Mitarbeiter Ihre Getriebe und -baureihen – sowohl auf Vorrat, als auch auftragsbezogen. Trotz Spezialanfertigungen zeichnen wir uns durch eine sehr hohe Lieferbereitschaft und ausgezeichnete Logistik aus. ATEK garantiert damit extrem kurze Lieferzeiten von oft weniger als 24 Stunden.

bequem, schnell und flexibel:

Für uns steht Ihre Zufriedenheit an erster Stelle. Daher machen wir es Ihnen auch so leicht wie möglich, mit uns in Kontakt zu treten bzw. Ihre Bestellung aufzugeben. Schicken Sie Anfragen oder Bestellungen mit der Post oder einfach per Anfrage- bzw. Bestellformular an die ATEK. Umfassende Informationen finden Sie außerdem auf unser Website.



Viele Antworten zu Getriebefragen auch unter www.atek.de
Many answers to questions about transmission at www.atek.de



Nutzen Sie die vielen Möglichkeiten unserer Seite: www.atek.de
Take advantage of our website: www.atek.de

committed and competent:

We cultivate long-term relations with our customers. Loyalty, confidence and close cooperation are first and foremost. The extensive, competent customer advisory service – from initial inquiries through delivery and installation to support with questions about maintenance – receives top priority at ATEK. With well-directed information and feedback, you – as our customer and partner – can help us to continue to meet your demands and requirements in the best way possible.

customized, high-quality solutions:

No matter what your requirements, ATEK can provide a customized solution for almost any application – produced using state-of-the-art technology and at an extremely competitive price. Our quality management system, which is certified in accordance with DIN ISO 9001, ensures not only quality consciousness, but also the constant monitoring and optimization of our processes.

everything in stock and ready to assemble:

ATEK has everything you need for right angle power transmission. Our specialized employees assemble your transmissions and products from stocks of pre-assembled units – both off-the-shelf and made-to-order. Despite special production, our processes are distinguished by very high availability and outstanding logistics. ATEK guarantees extremely short delivery times, frequently within 24 hours.

comfortably, fast and flexible:

Your satisfaction is our top priority. That is why we make it as easy as possible for you to contact us and to submit your order. Send your inquiries or orders by mail or with the inquiry or order form to ATEK. You can also find extensive information at our website.

Testen Sie unseren **Getriebekonfigurator!** *Try our **Gearbox Configurator!***

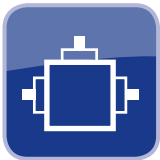

Kegelradgetriebe
Bevel Gearboxes



Hypoid - Getriebe
Hypoid Gearboxes



Leichtbaugetriebe
Light Weight Gearboxes



AdServo Getriebe
AdServo Gearboxes



Schneckengetriebe
Worm Gearboxes



Radsätze
Gear Sets

